



MAZAGON DOCK SHIPBUILDERS LIMITED
DOCKYARD ROAD, MUMBAI - 400010

EOI REF No.: MDL/GM(M)/Intg-Proc/Eoi/2026/01 Dated 27.02.2026

Corrigendum-3

Date: - 31 Mar 2026

1. The drawing for Pad type Bulkhead piece has been revised by adding dimensions of 15 NB to 32 NB bulkhead fittings.

<u>Original</u>	<u>Amended</u>
<p>1. Annexure-17: Drawings: DPSU-STD-DBH-STA-CST-PN010, DPSU-STD-DBH-PAD-CNI-PN010 and DPSU-STD-DBH-BUS-CNI-PN010 dated 10 Feb 2026</p> <p>2. Description of item no. 134 to 147 of Annexure-1: Centre pad type Deck / bulkhead piece for 90/10 Cu Ni Pipes, As per drawing DPSU-STD-DBH-PAD-CNI-PN010.</p>	<p>1. Annexure 17: Drawings: DPSU-STD-DBH-STA-CST-PN010 & DPSU-STD-DBH-BUS-CNI-PN010 dated 10 Feb 2026; DPSU-STD-DBH-PAD-CNI-PN010 Rev 1 dated 24.03.2026</p> <p>2. Description of item no. 134 to 147 of Annexure-1: Centre pad type Deck / bulkhead piece for 90/10 Cu Ni Pipes, As per drawing DPSU-STD-DBH-PAD-CNI-PN010, Rev 1, dt. 24.03.2026.</p>

2. **All other terms and conditions of the Eoi remain unchanged.**

CAPTIVE EXPRESSION OF INTEREST (CAPTIVE EOI) FOR SHORTLISTING OF MSME MANUFACTURERS & START-UPS FOR SUPPLY OF PIPES, FLANGES, & DECK BULKHEAD FITTINGS FOR MDL, GRSE, HSL & GSL UNDER PARALLEL RATE CONTRACT

1. Preamble:

- 1.1 Defence Public Sector Shipyards MDL, GRSE, HSL & GSL, under the administrative control of the Department of Defence Production (DDP), Ministry of Defence (MoD), Government of India, are engaged in the construction of warships, submarines and other commercial vessels including ship repair activities simultaneously at Mumbai, Kolkata, Visakhapatnam & Goa respectively. The construction activities require Pipes, Flanges & Deck Bulkhead Fittings which needs to be supplied in the specified time frame. In order to regulate the supplies for their Project requirements, Defence Public Sector Shipyards invites "Expression of Interest" (EOI) from interested MSME manufacturers & Start-Ups to join Defence Public Sector Shipyards as the business partners for Supply of Pipes, Flanges & Deck Bulkhead Fittings & other items of various material and denominations on Long term partnership basis.
- 1.2 The prospective MSME manufacturers including Start-Ups Suppliers shall submit the requisite documents as sought in this Eoi for evaluation by the Defence Public Sector Shipyards to shortlist capable vendors for empanelment and thereafter issuance of the Limited Tender for long term Rate Contract. All the Manufacturers registered under the MSME category or supplying to any of the four Defence Public Sector Shipyards has to also file the response against this Eoi as this Eoi is captive in nature and therefore Limited Tender would be issued only to shortlisted qualified bidders for undertaking Long term contracts for supplying these items to all four Defence Public Sector Shipyards .
- 1.3 The purpose of shortlisting is to create a pool of suitable MSME manufacturers & Start-Ups with valid credentials for supply of Pipes, Flanges & Deck Bulkhead Fittings and other items. This shortlisting is for issuance of the Limited Tender for long term Rate Contract, which will initially be made for a period of 3 years which may be extended for next 2 years on yearly basis subject to satisfactory performance of the firm during the execution period.

2. Clarification Meeting on Eoi:

- 2.1 An Eoi clarification meeting is scheduled on 9th Mar 2026 @10:00 hrs at MDL, Mumbai through VC i.e in virtual mode. Interested parties are requested to participate in the Pre-Eoi meeting with a purpose to seek clarifications on the supplies and on the Terms & Conditions of the Tender. Vendors are requested to forward the details of clarifications by email to contact details indicated at Para 25, for addressing the queries.
- 2.2 If the bidders need any clarifications on techno-commercial points, same may be forwarded in reasonable time (within one week of publication of the Eoi) as per the terms and conditions of the Eoi. The tentative date of Pre-Eoi meeting is indicated above. These clarifications will be sent even to those who have not sought the clarification.
- 2.3 Notwithstanding anything to the contrary herein, the bidder acknowledges that Defence Public Sector Shipyards shall endeavour to respond to any question or to provide any clarification, in its sole discretion, and nothing in this clause shall be taken or read as compelling or requiring Defence Public Sector Shipyards to respond to any question or to provide any clarification or make modification to RFQ documentation which will have material adverse effect on the bidding outcome. Defence Public Sector Shipyards may also on its own motion, if deemed necessary, issue interpretations and clarifications to each bidder.
3. The MSME manufacturers & Start-Ups will be shortlisted for issuance of the Limited Tender for long term Rate Contract for Supply of Pipes, Flanges, Deck Bulkhead Fittings and other items specified under Para 3.1. A scope of the supply and standard conditions for supply are specified at **Annexure-1**. The MSME manufacturers including Start-Ups, who desire to be considered for the shortlisting for meeting the Long Term requirement of the Defence Public Sector Shipyards , should clearly mention the items they have applied for in the prescribed **Application format** as per **Annexure-2**.

Note: - MSME firms interested to participating in the EOI are encouraged to get themselves registered as vendors in each of the 4 DPSU Shipyards as the earliest, in case they are not yet registered.

3.1 **Description of Supply:** The supply category for Shortlisting / empanelment is invited are as under:

- (I) Carbon Steel Pipes
- (II) Copper Pipes
- (III) Cu-Ni Pipes
- (IV) CS Flanges
- (V) Mild Steel Flanges
- (VI) Gun Metal Flanges
- (VII) Deck Bulkhead Fittings

4. **Eligibility / Pre-Qualification Criteria:** The shortlisting shall be based on the following pre-qualification criteria and subject to meeting other terms and conditions. The MSME manufacturers including Start-Ups applying against this EOI shall clearly indicate the product category / product group for which shortlisting is sought and attach the relevant supporting documents.

4.1 **Technical Pre-Qualification Criteria / Past Experience:**

- (i) The firm shall be MSME manufacturers or Start-Ups and have experience in Manufacture and Supply of items on specific product group basis eg Pipes, Flanges & Deck Bulkhead Fittings to marine / ship building / ship repair / Heavy Engg. industry or any engineering industry regularly for at least during the last three years, ending on previous day of the date of closing of this Eol, with the same or higher specifications indicated in this for qualification for limited tender under respective category. Firms are required to submit PO copies along with work completion certificates OR any other document(s) establishing successful execution of PO/Contract in support of past experience. The specification of the items are specified at **Annexure 1**.
- (ii) The firm is required to submit application in the prescribed format as per **Annexure-2** indicating the product category / product group for which shortlisting is requested. To qualify for empanelment for a particular category as mentioned above, the vendor should meet financial and previous experience criteria mentioned in subsequent Paras.
- (iii) Firm shall not be under the purview of tender holidays / adverse ratings by any Government organization or large corporates on the date of Eol closing. Firm to submit an undertaking along with the bid in this regard.
- (iv) The firms are required to submit detailed information about previous experience in the prescribed format as per **Annexure-3** indicating details of previous purchase orders, nature of work carried out, PO value, start and completion of work period against which they are meeting the qualifying criteria of the applied category of work. One of the following documents may be considered as valid proof for execution of purchase order:
 - Contract copy along with Invoice(s) with self-certification by the bidder that supplies against the invoices have been executed.
 - Contract copy along with Execution certificate by client with contract value.
 - Contract copy along with any other document in support of contract execution like Third Party Inspection release note with Delivery challan with purchaser stamp.
- (v) Defence Public Sector Shipyards has the right to verify/ cross verification of authenticity of the said documents whenever felt necessary.

- (vi) **Only those PO copies / WDCs which are mentioned in the Annexure-3 of the EOI will be considered for evaluation and Qualification of the vendor. Any other PO copy, not mentioned in the Annexure -3 will not be scrutinised and will not be considered for evaluation.**

4.2 Commercial Qualification Criteria:

- (i) The Commercial Pre-Qualification Criteria includes supplier's company profile and the financial status. Suppliers shall invariably submit their company profile as per **Annexure-4** duly filled in and attach the supporting documents to verify their credentials and status.
- (ii) Bidders Shop and establishment registration certificate or registration certificate from registrar of firms or certificate of incorporation from Registrar of Companies.
- (iii) **Financial Capability:** The average annual financial turnover of 'The bidder' during the last three years e.g. If application is submitted in the year 2026 then Annual Average Turnover of FY (2022-23), FY (2023-24) and FY (2024-25) will be considered) shall be as indicated in the below table, as per the annual report (audited balance sheet and profit and loss account) of the relevant period, duly authenticated by a Chartered Accountant/Cost Accountant in India.

Sr. No	Category	Annual Average Turnover during last three Financial Years in INR in Lakhs for assessing financial capability
1	Carbon Steel Pipes	75
2	Copper Pipes	35
3	Cu-Ni Pipes	175
4	CS Flanges	7.5
5	Mild Steel Flanges	15
6	Gun Metal Flanges	125
7	Deck Bulkhead Fittings	75

Note:

- a) Start-ups shall be given 100% relaxation in prior turnover and prior experience subject to meeting of quality, technical specifications and proven manufacturing credentials. Supplier to submit valid Start-ups certificate as recognized by Department of Industrial Policy and Promotion (DIPP).
- b) MSE Manufacturers shall be given 100% relaxation of prior turnover and prior experience subject to meeting of quality, technical specifications and proven manufacturing credentials.
- (iv) Applicability to 'Make in India': Bidders (manufacturer or principal of authorized representative) who have a valid/approved on going 'Make in India' agreement/program and who while meeting all other criteria above, except for any or more of sub-criteria in Experience and Past Performance above, would also be considered to be qualified provided:
- a) their foreign 'Make-in-India' associates meet all the criteria above without exemption, and
- b) the Bidder submits appropriate documentary proof for a valid/approved on going 'Make in India' agreement/program.
- c) the bidder (manufacturer or principal of authorized representative) furnishes along with the bid a legally enforceable undertaking jointly executed by himself and such foreign Manufacturer for satisfactory manufacture, Supply (and erection, commissioning if applicable) and performance of 'The Product' offered including all warranty obligations as per the general and special conditions of contract

Note: In case the date of constitution / incorporation of the bidder is less than 3-year-old, the average turnover in respect of the completed financial years after the date of constitution shall be taken into account for this criteria.

Note: Joint Ventures and Holding Companies:

Joint Ventures: Credentials of the partners of Joint ventures cannot (repeat cannot) be clubbed for the purpose of compliance of PQC in supply of Goods/Equipment, and each partner must comply with all the PQC criteria independently.

Holding Companies: Credentials of the Holding company cannot (repeat cannot) be clubbed for the purpose of compliance of PQC in supply of Goods / Equipment, and each subsidiary bidding company must comply with all the PQC criteria independently. However, the Financial Standing credentials of a Holding Company can be clubbed with only one of its subsidiary bidding company having shares 51% and more with appropriate legal documents proving such ownership. Cases where Holding Company is not fully (100%) owning the subsidiary bidding company, then Holding Company shall also provide a corporate guarantee on the subsidiary bidding company.

5. Bid Rejection Criteria:

5.1 The following conditions / deviations are non-negotiable and therefore any bid falling under these conditions / deviations shall be summarily rejected. Bidders to note that they shall not be provided any opportunity to rectify these conditions / deviations post EoI bid opening:

- (i) Bidders who are debarred under PPP MII order 2017, GeM, CPPP including Tender holiday issued by MDL / GRSE / HSL / GSL.
- (ii) Only Class-I local suppliers are eligible to qualify for empanelment. Bids received from suppliers other than Class-I will be rejected categorically. The definition of Class-I Local Supplier, Class-II Local Supplier and Non-Local Suppliers is defined at para 7.20.
- (iii) Bidders who are other than MSME Manufacturers & Start-Ups
- (iv) Bidders including Start-Ups and MSMEs who are not able to prove the quality, technical specifications and manufacturing credentials
- (v) The firm shall not be under the purview of tender holidays / adverse ratings by any Government organization or large corporates on the date of EoI closing.
- (vi) Bids received after EoI Closing date and time.

5.2 In case offers received with deviations to the terms and conditions of EOI other than indicated at 4 above and offers received without supporting documents, Defence Public Sector Shipyards may provide an opportunity and additional time equally to all the bidders for submission of deficient techno-commercial documents and clarification. Bidders are required to submit such documents / clarifications within the duration / time stipulated by Defence Public Sector Shipyards, failing which their bids will be liable for rejection. Such additional time and opportunity will be provided on need basis.

6. Shortlisted MSME Manufacturers & Start-Ups:

6.1 The shortlisted contractors shall be issued limited Tender for executing Long Term Contract for supply of these items wherein the L1 ranking Criteria, Price matching criteria, number of bidders to be considered for awarding Rate Contract based on nature of the items would be clearly stipulated. The awarding of progressive supply order will be at the discretion of Defence Public Sector Shipyards subject to availability of projects and scope of requirement from time to time. Qualification through this EoI or Conferment of Rate Contract does not entitle the bidder for award of supply order.

6.2 Defence Public Sector Shipyards reserves the rights to accept, consider or reject any or all applications without assigning any reasons thereof. The decision of Defence Public Sector Shipyards in respect of registration / empanelment / shortlisting of suppliers for various categories of items will be intimated by NIC / post /email and shall be final & binding on all concerned registered firms / vendors.

6.3 The quantities indicated are our anticipated requirement, however progressive orders will be placed by the Defence Shipyard on the need basis during the currency of the Rate contract. Defence Public Sector Shipyards are not bound to order entire quantity as indicated during the tenure of the contract.

6.4 Quantity indicated against each progressive order placed on you periodically / progressively as per our requirement must be completed in full within delivery period indicated on the order. In case of non-acceptance of confirmatory order or failure to meet the supplies within the timeline given in the confirmed PO, the order would be cancelled and the firm would be weeded out by cancelling the Rate contract. The entire modality for contract finalization, award of the confirmed PO under the Rate Contract, execution, monitoring of Execution, performance rating, weeding out the vendor etc. would be clearly stated in the Tender document which would be issued after evaluation of vendor's credentials received against this EoI against the Pre-Qualification criteria.

7. Terms & Conditions applicable to Shortlisted MSME Manufacturers & Start-Ups:

7.1 Only the shortlisted vendors shall be issued limited tender for discovering the price for Rate Contract. Reverse Auction may be conducted post tendering based on the response to this EoI.

7.2 All shortlisted firms are expected to maintain absolute integrity, follow ethical business standards and do nothing as unbecoming of a Long Term Partner.

7.3 Performance Security (PS):

(i) On placement of confirmatory PO (progressive PO) to the Long Term Contractor, the Performance Security for an amount equal to 5% of the order value (excluding taxes, duties) payable in Indian Rupees shall be submitted to the confirmatory Order placing Shipyard within 25 days of the award of confirmatory PO and the same should remain valid for a period of 60 (sixty) days beyond the date of completion of warranty / guarantee obligations & discharge of all contractual obligations.

(ii) Performance security may be furnished in the form of NEFT / Demand Draft / Pay order / Bank Guarantee / Insurance Security Bond / Insurance Surety Bond / e-Bank Guarantee in favour of <Progressive order placing Defence Shipyard> from the list of Banks approved by SBI / Canara Bank published on <Progressive order placing Defence Shipyard> website.

(iii) In cases where the supplier / contractor does not submit the PS but commences supply / services, interest will be recovered for the delayed period of submission of PS at the rate of SBI BPLR plus 2%.

(iv) The performance security will be forfeited and credited to Progressive order placing Defence Shipyard's account in the event of a breach of contract by the contractor.

(v) The performance security will be refunded to the contractor without any interest, after the satisfactory performance against confirmatory order within 60(sixty) days of completion of all such obligations including the warranty under the contract.

(vi) No exemption can be granted to any unit including MSME, SSI units and Defence Shipyard Registered Supplier for regulating the supply for meeting the Defence Project requirement having National significance & for meeting domestic & Export obligations for other Projects.

7.4 Warranty/Guarantee:

(i) The items supplied shall be guaranteed for minimum 12 months from the date of receipt and acceptance of items at Defence Public Sector Shipyards .

(ii) The supplier cannot absolve their responsibility for warranty of material even though it is inspected & approved by inspection authorities.

- (iii) During guarantee period if material is found to be defective, the supplier shall have to arrange dispatch of new material on CIF basis. On arrival of new material, supplier should have to collect defective material. All addition cost towards replacement against defective items shall be borne by the supplier.

7.5 **Tie Breaker:** When multiple vendors quote same price for particular item(s)/services under such situation, following action in given sequence shall be done: (a) In case of divisible, 50-50 qty to be given to each. (b) In case of non-divisible, supplementary bid asking for discount to be obtained. (c) In case of both divisible or non-divisible, lottery option to be exercised after above options are not conclusive.

7.6 **Taxes & Duties:**

- (i) Supplier / contractor will not be entitled to any increase in rate of taxes occurring during the period of extended delivery completion schedule if there is delay in supplies / completion attributed to him. However, if there is a decrease in taxes, the same must be passed on to Defence Public Sector Shipyards.
- (ii) Goods and Services Tax (GST):
 - (a) GST shall be payable extra as agreed as per GST Laws.
 - (b) In case of purchases of goods/services from unregistered dealers under GST Laws, GST will be paid by Progressive order placing Defence Shipyard under reverse charge mechanism.
 - (c) Benefits from reduction in rate of tax/ITC is required to be passed on to consumer. Where "applicable GST" has been quoted as extra, Goods and service providers (except un-registered dealers under GST Law) have to submit declaration that they have complied with 'Anti-profiteering clause' under GST Law. Such declaration be given in technical bid.
 - (d) If the vendor is registered under GST, vendor shall mention the HSN code for goods and/or services in their tax invoice, etc. These codes must be in accordance with GST Laws and responsibility of specifying correct HSN codes for goods and/or services is that of the vendor. Defence Public Sector Shipyards shall not be responsible for any error in HSN code for goods and/or services specified by supplier / contractor. Supplier /Contractor shall pay penalty and/ or interest imposed on Defence Public Sector Shipyards or any loss due to delay in availing ITC by Defence Public Sector Shipyards or any loss of ITC to Defence Public Sector Shipyards due to errors by vendors at any stage. Defence Public Sector Shipyards reserves right to recover any such interest, penalty or loss from any amount due to supplier /contractor or otherwise
 - (e) In case, Defence Public Sector Shipyards are unable to avail ITC, supplier/contractor at their own cost shall rectify the shortcoming in the returns to be filed immediately thereafter. Further, if the ITC is delayed / denied to Defence Public Sector Shipyards / reversed subsequently as per GST Laws due to non / delayed receipt of goods and / or services and / or tax invoice or expiry of timelines prescribed in GST Laws for availing ITC, non-payment of taxes or non-filing of returns or any other reason not attributable to Defence Public Sector Shipyards, supplier /contractor shall pay any loss of amount along with interest and penalty on Defence Public Sector Shipyards under GST Laws for the number of days the ITC was delayed. If the short coming is not rectified by supplier/contractor and Defence Public Sector Shipyards ends up in reversal of credits and / or payments, supplier /contractor is fully liable for making good all the loss incurred by Defence Public Sector Shipyards. Defence Public Sector Shipyards reserves right to recover any interest, penalty or loss from any amount due to supplier /contractor or otherwise.

- (f) If the vendor is registered under GST, the GST registration number (15 digit GSTIN) issued by GoI shall be mandatorily provided by the vendor. Vendor having multiple business verticals within state / at multiple states with separate GST registration numbers shall forward GSTIN of only that vertical which is involved in supply of goods and/or services. MDL GSTIN is 27AAACM8029J1ZA / GRSE GSTIN 19AAACG9371K1Z4 / HSL GSTIN 37AAACH4275P1Z2 / GSL GSTIN 30AAACG7569F1ZR and vendor shall mention the same while invoicing and avoid any data entry error on GST portal.
- (g) If the vendor is registered under GST; Vendor shall ensure timely submission of invoice as per the provisions / requirement / timeline promulgated by GOI in relation to GST Law with all required supporting documents to enable Defence Public Sector Shipyards to avail input tax credit promptly. The vendors invoice inter alia should contain GSTIN of vendor, GSTIN of MDL (i.e. 27AAACM8029J1ZA) or GSTIN of Defence Shipyard placing the progressive Contract (ie GRSE GSTIN 19AAACG9371K1Z4 / HSL GSTIN 37AAACH4275P1Z2 / GSL GSTIN 30AAACG7569F1ZR), GST tax rate separately, HSN code wise goods or services, place of supply, signature of vendor, etc. Original invoice needs to be submitted to Bill Receipt Centre at MDL gate, and a copy of the invoice should be given to the goods receiving section (GRS) or as applicable at the Confirmatory Order placing Defence Public Sector Shipyard.
- (h) If the vendor is registered under GST, vendor shall file all applicable returns under GST Laws in the stipulated time and any losses of tax credit to Defence Public Sector Shipyards arising due to delay in filing will be recovered from their invoice wherever Defence Public Sector Shipyards is eligible to avail tax credit. Any default towards payment of tax and / or uploading of monthly returns by supplier/contractor, Defence Public Sector Shipyards retains right to withhold payments towards tax portion until the same is corrected and complied by the supplier/contractor with the requirement of GST along with satisfactory evidence.
- (i) The GST will be applicable on total basic rate of each item (Inclusive of packing forwarding, freight & insurance).

7.7 E-invoice:

- (a) The vendors, whose aggregate turnover in any preceding financial year from FY 2017-18 onwards, exceeds INR 5 crore as per GST Act or as applicable from time to time, will have to issue an e-Invoice with a Quick Response (QR) code and Invoice Registration No.(IRN),
- (b) The vendors, having aggregate turnover in any preceding financial year from FY 2017-18 onwards not exceeding INR 5 crore must submit digitally signed invoice.
- (c) It is important to note that Defence Public Sector Shipyards will not be entitled for Input Tax Credit (ITC)/GST on a vendor Invoice which is not compliant with the above e-Invoice notification.
- (d) Wherever GST is applicable, payment will be released against e-Invoice, or Invoice accompanied with vendor's self-declaration that "we do not fall under the category of registered persons notified under Rule 48(4) of the Central GST Rules, 2017 and we are not required to comply with e-Invoicing provisions under GST Act, as our aggregate turnover in any preceding financial year from 2017-18 onwards has not exceeded INR 5 crore as per GST Act".

7.8 Inspection

Inspection requirements i.e. either by Shipyard or TPI or Self certification etc. will be mentioned in the Tender Document.

7.9 **Delivery Locations:**

The EoI is for shortlisting capable vendor for supply of pipes, flanges, Deck Bulkhead Fittings & other items to all the Defence Public Sector Shipyards i.e. MDL, GRSE, HSL & GSL. The delivery locations for the Shipyards are as tabulated below:

Sr. No	Shipyards	State & City	Delivery Location Address
1	Mazagon Dock Shipbuilders Limited (MDL)	Maharashtra, Mumbai	Mazagon Dock Shipbuilders Limited, Anik Chembur Store, Mahul Road, Near Vengsarkar Academy, Mumbai -400074.
2	Garden Reach Shipbuilders Limited (GRSE)	Kolkata, West Bengal	Garden Reach Shipbuilders & Engineers Limited 43/46 Garden Reach Road Kolkata 700024
3	Hindustan Shipyard Limited	Visakhapatnam, Andhra Pradesh	Hindustan Shipyard Limited, Gandhigram, Visakhapatnam - 530005
4	Goa Shipyard Limited	Goa, Vasco Da Gama	Main Stores Building, Goa Shipyard Ltd, Vasco Da Gama, Goa - 403802

7.10 **Price:**

- (i) Bidders shall quote for delivery of the items to the all the delivery locations including charges towards inland transportation, insurance, unloading charges and other local costs incidental to the delivery of the Goods/Services which would be clearly stipulated in the tender document including seeking the cost breakups.
- (ii) Rate Contract Period: The Rate Contract period would be for 3 years extendable by another two years. PVC will not be applicable for first twelve months. PVC will be applicable for progressive Contracts placed beyond 12 months and the PVC clause would be incorporated in the Tender.

7.11 **Loading Criteria:**

Deviations sought by the bidder shall be loaded on the bidder/s quoted prices during price evaluation by Defence Public Sector Shipyards for ranking of bids to judge L1, as under.

- (a) Varied payment terms quoted by indigenous bidders as compared to the terms stated in the Tender document shall be normalized by adopting the Benchmark Prime Lending Rate of State Bank of India plus 2% thereon on the amount (s) at variation and / or for the period (in no. of days) at variation.

7.12 **Evaluation of EoI:**

The vendors shall be evaluated based on the Pre-Qualification Criteria stipulated herein. The Qualified vendors shall be empanelled for issue of limited tender for supply of the items / category for rate contract for which they are qualified.

7.13 **Limited Tender and Evaluation**

- (i) EoI Qualified vendors will be issued Limited tender
- (ii) Ranking of Bids: Tender line items will be separable and divisible in nature.
 - (a) Techno-Commercially Qualified Lowest Bidder on item wise basis will be considered for processing of placement of order/contract

- (b) Ranking of bids shall be done by considering following factors:
 - (i) The comparison of the responsive tenders shall be on total outgo on Least Cost Net of Credit Basis (LCNC), for the procurement to be paid to the supplier or service provider, including all elements of costs, duties, levies, freight, insurance etc. excluding GST (where ITC is available). Therefore, it shall be on the basis of CIF/ FOR destination basis, duly delivered, commissioned, as the case may be.
 - (ii) The applicable loading towards deviations shall be loaded for ranking purpose.
- (c) Discount given, if any, by the bidders, after the last date for submission of the bids but before opening of the price bids, will not be considered for determining the ranking of bids but will be considered after the said bidder is adjudged as L1.
- (d) On-line ranking visible to the bidders after opening Part-II price bid is without loading parameters. However, the L1 bidder will be evaluated offline by applying all applicable loading parameters as per tender and clarifications during techno-commercial scrutiny / TNC meeting.
- (e) Loading/Ranking will be done on original submitted bid at the time of closing of tender. However, in case Defence Public Sector Shipyards invites supplementary price bid from technically qualified bidders, then same will also be considered while ranking of bids.
- (f) In case of any discrepancy in the Blank Rate Schedule Format and actual On-Line Price Bid after opening of the price bids, the details mentioned in the On-Line Price Bids shall prevail over the details in blank rate schedule format.
- (iii) Reverse Auction shall be conducted as per provisions on the e-procurement platform. H1 elimination criteria shall be applicable.

7.14 Empanelment Rate Contracts

- (i) Upon limited tendering and reverse auction, the L1 vendor will be considered for rate contract at the discovered prices. The other vendors, in the order of ranking, will be offered for price matching with L1 prices for consideration of rate contract empanelment, which will be followed till the number of empanelled vendors as declared in the Limited Tender is reached.
- (ii) Number of empanelled vendors shall be decided based on the response to EOI and will be specified in the Limited Tender issued to the EOI qualified Bidders.

7.15 Progressive / Confirmation Contracts

- (i) Based on the Empanelment Rate Contract placed by the EOI / Tender issuing Shipyard, the EOI / Tender issuing Shipyard as well as all other Defence Public Sector Shipyard would issue Progressive / Confirmation Contracts to the empanelled vendor within the overall contracted quantity.
- (ii) Procedure for placing Progressive/ confirmation contracts post Rate contracts will be based on the response to this EOI and will be elaborated in the tender document:

7.16 Option Clause: Defence Public Sector Shipyards retains the right to place orders for an additional quantity up to 100% of the originally contracted quantity at the same rate and terms & conditions of the contract, during the currency of the contract.

7.17 Payment Terms:

- (i) No advance in any manner will be paid.
- (ii) Payment shall be made as per actual quantity received and accepted. 100% Payment shall be made within 30 days of receipt/completion of material/services subject to acceptance of material/services and as reduced by any deductibles (example: Performance Security etc.) and / or the amount leviable towards liquidated damages, if any plus 100% taxes, duties etc. as applicable.
- (iii) Part payment against part supply shall be made.

- (iv) Bidders shall furnish all the necessary details like name of the bank / branch, branch code No, bank account no in their technical bid as per the RTGS/NEFT/ECS format provided with the tender enquiry
- (v) The bills to be addressed to Commercial Department of the Confirmatory Contract placing Defence Shipyard and should be forwarded / submitted to their Invoice Receipts Section.
- (vi) Invoice become payable only after receipt & acceptance of the material at the Defence Public Sector Shipyards. Defence Public Sector Shipyards shall not be responsible for delay in payment because of errors in invoice with regard to HSN number, missing/incorrect PO no and its line-item number or Incorrect Item Description etc. Vendors are advised to ensure correctness of invoices in line with the PO. Each invoice shall have reference of Defence Public Sector Shipyards PO No. and respective PO line item.
- (vii) Trade Receivable Discounting System (TReDS) for MSEs:

In order to address the financial needs of MSME firms, GoI has introduced a platform for facilitating the financing of trade receivables of MSMEs from buyers, through multiple financiers which is termed as Trade Receivables Discounting System (TReDS). At TReDS, auctioning of invoices at competitive & transparent environment is done by financiers based on Buyer's credit profile.

MSME bidders desirous to receive payments through TReDS platform may avail the facility if they are already registered on TReDS platform or by registering on it.

Kindly note that submission of the above documents with the invoice is essential for effecting (timely) payment to the Subcontractor.

7.18 Price Variation Clause:

- (i) Price Variation Clause will be applicable only upon completion of one year from the date of rate contract based on the Nearest WPI Index applicable to each item. Upon completion of one year, the prices during the remaining tenure of the contract will be governed by the price variation clause, which is as follows

- a. Pipes (Carbon Steel Pipes) :

$$P1=P0\{0.15+0.85*(WPI_d/WPI_p)\}$$

Where:

P1=Progressive / Confirmative Contract Price

P0=Empanelled price

WPI_d=WPI Index of "Steel pipes, tubes & poles" as on the Progressive / Confirmative Contract issuance date month published by Office of Economic Advisor, GoI

WPI_p= WPI Index of "Steel pipes, tubes & poles" as on the tender closing date month published by Office of Economic Advisor, GoI

- b. Pipes (Copper Pipes & Cu-Ni Pipes) :

$$P1=P0\{0.15+0.85*(WPI_d/WPI_p)\}$$

Where:

P1=Progressive / Confirmative Contract Price

P0=Empanelled price

WPI_d=WPI Index of "Copper metal / Copper rings" as on the Progressive / Confirmative Contract issuance date month published by Office of Economic Advisor, GoI

WPIp= WPI Index of “Copper metal / Copper rings” as on the tender closing date month published by Office of Economic Advisor, Gol

c. Flanges (Mild Steel, Carbon Steel) :

$$P1=P0\{0.15+0.85*(WPId/WPIp)\}$$

Where:

P1=Progressive / Confirmative Contract Price

P0=Empanelled price

WPId=WPI Index of “Mild steel (MS) flats & sheets” as on the Progressive / Confirmative Contract issuance date month published by Office of Economic Advisor, Gol

WPIp= WPI Index of “Mild steel (MS) flats & sheets” as on the tender closing date month published by Office of Economic Advisor, Gol

d. Flanges (Gun Metal) :

$$P1=P0\{0.15+0.85*(WPId/WPIp)\}$$

Where:

P1=Progressive / Confirmative Contract Price

P0=Empanelled price

WPId=WPI Index of “Copper metal / Copper rings” as on the Progressive / Confirmative Contract issuance date month published by Office of Economic Advisor, Gol

WPIp= WPI Index of “Copper metal / Copper rings” as on the tender closing date month published by Office of Economic Advisor, Gol

e. Deck Bulkhead Fittings (Mild Steel) :

$$P1=P0\{0.15+0.85*(WPId/WPIp)\}$$

Where:

P1=Progressive / Confirmative Contract Price

P0=Empanelled price

WPId=WPI Index of “Mild steel (MS) flats & sheets” as on the Progressive / Confirmative Contract issuance date month published by Office of Economic Advisor, Gol

WPIp= WPI Index of “Mild steel (MS) flats & sheets” as on the tender closing date month published by Office of Economic Advisor, Gol

No escalation will be given for first twelve (12) months from the data of empanelment. PVC shall be applicable for all confirmatory orders placed beyond six months from the date of empanelment.

f. Deck Bulkhead Fittings (Gun Metal):

$$P1=P0\{0.15+0.85*(WPId/WPIp)\}$$

Where:

P1=Progressive / Confirmative Contract Price

P0=Empanelled price

WPId=WPI Index of “Copper metal / Copper rings” as on the Progressive / Confirmative Contract issuance date month published by Office of Economic Advisor, Gol

WPIp= WPI Index of “Copper metal / Copper rings” as on the tender closing date month published by Office of Economic Advisor, Gol

No escalation will be given for first twelve (12) months from the date of empanelment. PVC shall be applicable for all confirmatory orders placed beyond six months from the date of empanelment.

- (ii) No price adjustment shall be payable if the variation / price adjustment is less than or equal to 2% (two per cent)

7.19 Liquidated damages / Penalty:

Time is the essence of the Contract/PO. Therefore, the job, as Ordered, should be completed on the dates mutually agreed upon in accordance with the delivery schedule.

LD rate: A sum of 0.5% (half per cent) per week or part thereof, of the delayed supply (undelivered portion of supply) subject to maximum of 10% of value of delayed supply (undelivered portion of supply) of the package/ schedule in each case.

7.20 Purchase Preference to Make in India Order 2017:

The Government of India has issued revised Public Procurement (Preference to Make in India) order 2017 on 19th July' 2024 as part of its policy to encourage "Make in India" and promote manufacturing and production of goods and services in India with a view to enhancing income and employment. Subject to the provisions of this order and to any specific instructions issued by Nodal Ministry or in pursuance of this order, Purchase Preference shall be given to local suppliers in all the procurements undertaken by Defence Public Sector Shipyards as per this order.

- (i) Aspects of 'Preference to Make in India': The following terminology / definitions used in the policy is enumerated below and applicable to the tender:

- (a) Local content: means the amount of value added in India which shall be the total value of item (goods, services or works or their combination) under procurement (excluding net domestic indirect taxes) minus the value of imported content in the item (including all customs duties) as a proportion of the total value in percent. Different definition of Local Content may be specified by the Nodal Ministry for items assigned to them, which will prevail over above.

- (ii) Explanatory notes for calculation of local content given above

- (a) Imported items sourced locally from resellers/distributors shall be excluded from calculation of local content.
- (b) The license fees/royalties paid/technical charges paid out of India shall be excluded from local content calculation.

- (c) Procurement/Supply of repackaged/refurbished/rebranded imported products as understood commonly shall be treated as reselling of imported products and shall be excluded from calculation of local content. The definition of repackaged/refurbished/rebranded imported products is as follows;

'Refurbishing' means repair or reconditioning of an imported product does not amount to manufacture because no new goods come into existence.

'Repackaging' means repacking of imported goods from bulk pack to smaller packs would not ordinarily amount to manufacture of a new item.

'Rebranding' means relabelling or renaming or change in symbol or logo/makes or corporate image of a company/organization firm for an imported product would amount to rebranding.

- (d) To ensure that imported items sourced locally from resellers/distributors are excluded from calculation of local content, procuring entities to obtain from bidders, the cost of such locally-sourced imported items (Inclusive of taxes) along with break-up on license/royalties paid/ technical expertise cost etc. sourced from outside India. For items sold by bidder as reseller, OEM certificate for country of origin to be submitted.

- (e) For contracts involving supply of multiple items, weighted average of all items to be taken while calculating the local content.

Note:

- (aa) The local content can be increased by vendors through partnerships, cooperation with local companies, establishing production units in India or Joint Ventures (JV) with Indian suppliers, increasing the participation of local employees in services and training them.
- (bb) Any participating bidder shall not be Joint Venture/Consortium; except in case of manufacture under license/technology collaboration agreements with phased indigenization under the PPP Make-in-India Policy 2017.
- (f) Class-I Local Supplier: means a supplier or service provider, whose goods, services or works offered for procurement, meets the minimum local content of 50%.
- (g) Class-II Local Supplier: means a supplier or service provider, whose goods, services or works offered for procurement, meets the minimum local content of 20% but less than that prescribed for "Class-I local supplier".
- (h) Non-Local Supplier: means a supplier or service provider, whose goods, services or works offered for procurement, has local content less than that prescribed for "Class-II local supplier" under this order.

(iii) Declaration/Verification of Local content:

- (a) Participating bidders to indicate the percentage of local content (i.e. value added in India) along with the details of location/s where the local value addition is made, in their bids in the prescribed format placed at **Annexure-17**. The indicated local content percentage shall decide categorization of the vendors as "Class-I Local Supplier" / "Class-II Local Supplier" / "Non-local Supplier". All bidders should declare that the item and service offered meets the minimum local content & indicate its percentage in their offer which shall meet the required local content specified in tender. This declaration is necessary even if Custom Duty Exemption and / or ERV (if applicable) are not being sought. Certification as under is to be submitted mandatorily in the Offer. Self-certification by Chief Financial Officer or Other legally responsible person nominated in writing by the Chief Executive or Senior Member / Person with Management Responsibility of Corporation / Partnership / Individual. However, in cases of procurement for value in excess of Rs. 10 Crores, the bidders shall provide a certificate from statutory auditor or cost auditor of the company (in case of companies) or from a practicing cost accountant or practicing chartered accountant (in respect of supplier other than companies) giving the percentage of local content.
- (b) For cases where it is not possible to provide certification by Cost/Chartered Accountant at the time of execution of project, the supplier shall be permitted to provide the certificate for local content from Cost/Chartered Accountant after completion of the contract, within time limit acceptable to the procuring entity (30 days of completion). In case the contractor/supplier does not meet the stipulated local content requirement and the category of the supplier changes from Class-I to Class-II /Non-local or from Class-II to Non-local, a penalty of 10% of the contract value shall be imposed which shall be withheld from the payment due to the bidder.
- (c) Once the declaration /certification is committed at tender submission stage, the same cannot be altered subsequently at technical negotiation stage or after award of contract. Doing so would be treated / considered as false declaration by bidder and necessary action will be initiated as per Para 9 of the said Order for debarment.
- (d) Declared Local Content shall be the basis for categorization of the vendors and tender evaluation. However, Defence Public Sector Shipyards reserves the right to undertake

detailed examination of declared local content and may call vendor to submit relevant documents.

- (e) In cases where Defence Public Sector Shipyards received the complaint from any vendor or person, along with the fees prescribed below, verification of Declared Local Content shall be carried out by seeking additional info as deemed necessary and the bidders (including unsuccessful bidders) against the tender shall be obliged to furnish the necessary documents. Failing to do so, the vendor may invite penal action as per the provisions of the Order. If Defence Public Sector Shipyards possess the capability, then it shall perform the verification. However, if in the opinion of Defence Public Sector Shipyards matter needs to be dealt at higher level, then the complaint shall be referred to Nodal Ministry and their fees / expenses / charges applicable as per the Nodal Ministry, if any, shall be borne by the complainant. Defence Public Sector Shipyards is authorized to prescribe fees for handling complaints under revised PPP MII 2017 Order. The fees for filing a complaint under the order shall be Rs. 10,000/- per case. The complaint shall be filed to the Chairman, Public Grievance Cell. The fee shall be deposited by complainant in Defence Public Sector Shipyard's Account by NEFT. (Defence Public Sector Shipyards account)
- (f) On scrutiny of offer, if all the bidders participating in the tender happen to have either not submitted the declaration certificate or not declared / specified the local content percentage in the declaration certificate or specified local content lower than the minimum local content requirement as per the tender, the subject tender shall be cancelled & matter shall be taken up with Ministry, by the user department, as per the procedure indicated at above Purchase Preference Para or as amended by MoD / DPIIT / DoE.
- (g) Note: The original of the uploaded copy of Local Content Declaration shall be received in Defence Public Sector Shipyards within seven working days from the tender closing date. Not receipt of the same is a "liable for bid rejection" criteria.

7.21 PPP MSE Order 2012: While awarding the Rate Contracts Vendors having MSE status will be given Purchase Preference as per PPP MSE Order 2012.

7.22 Integrity Pact:

- (i) The Integrity Pact essentially envisages the agreement between prospective vendors/bidders and buyers committing the persons / officials of both the parties not to exercise any corrupt influence on any aspect of the contract. Empanelled contractors for will have to sign an integrity pact with the buyer. The format of Integrity Pact is placed at **Annexure-11** and the same is to be strictly adhered to.
- (ii) Please note that the Bidders not agreeing to accept Integrity Pact would lead to rejection of their offer for empanelment. A scanned copy of the Integrity Pact duly signed by bidder, strictly as per the format given at **Annexure-11** is to be uploaded along with the application for empanelment. The original of the Integrity pact is to be submitted to Defence Public Sector Shipyards within 7 days of the EOI closing date.
- (iii) The nominated Independent External Monitor (IEM) will have power to access the entire project document and examine any complaints received by him. The details of nominated IEM from the panel of IEMs as on date are as follows:

1. Mr. M N Krishnamurthy IPS(Retd)

E-mail ID - krishnamurthymn19@gmail.com

2. Mr. Deepak Kashyap, IRTS (Retd)

E-mail ID - deepakkashyapnd02@gmail.com

For updated list of IEMs, Kindly visit MDL website www.mazagondock.in.

7.23 Debarment of bidders / suppliers:

- (i) False declaration will be in breach of Code of Integrity under Rule 175(1)(i)(h) of GFR 2017 for which a bidder or its successors can be debarred for up to 2 years as per Rule 151(iii) of GFR 2017 along with such other actions as may be permissible under law.
- (ii) A supplier who has been debarred by any procuring entity for violation of said Order shall not be eligible for preference under said Order for procurement by any other procuring entity for the duration of debarment. The debarment for such other procuring entities shall take effect prospectively from the date on which it comes to the notice of other procurement entities, in such a manner that ongoing procurements are not disrupted.

7.24 Land Border Clause: Restrictions under rule 144(xi) of general financial rules GFRs, (2017)

- (i) Any bidder from a country which shares a land border with India will be eligible to bid in any procurement whether of goods, services (including consultancy services and non-consultancy services) or works (including turnkey projects) only if the bidder is registered with the Competent Authority. Further, any bidder (including bidder from India) having specified Transfer of Technology (TOT) arrangement with an entity from a country which shares a land border with India, shall also require to be registered with the same competent authority. The competent authority for Purpose of registration under this order shall be registration committee constituted by department for promotion of industry and internal trade. (DPIIT). Bidder is therefore required to submit a declaration as per **Annexure-10**.
- (ii) Bidder means any person or firm or company, including any member of a consortium or joint venture (that is an association of several persons, or firms or companies), every artificial juridical, Person not falling in any of the descriptions or bidders stated hereinbefore, including any agency branch-or office controlled by such person, participating in a procurement process.
- (iii) Bidder from a country which shares a land border with India for the purpose of this Order means: -
 - (a) An entity incorporated, established or registered in such a country; or
 - (b) A subsidiary of an entity incorporated, established or registered in such a country; or
 - (c) An entity substantially controlled through entities incorporated, established or registered in such a country; or
 - (d) An entity whose beneficial owner is situated in such a country; or
 - (e) An Indian (or other) agent of such an entity; or
 - (f) A natural person who is a citizen of such a country; or
 - (g) A consortium or joint venture where any member of the consortium or joint venture falls under any of the above.
- (iv) The beneficial owner for the purpose of above stated clause, will be as under
 - (a) In case of a company or Limited Liability Partnership, the beneficial owner is the natural person (s), who, whether acting alone or together, or through one or more juridical person, has a controlling ownership interest or who exercises control through other means, Explanation: -
 - (aa) Controlling ownership interest" means ownership of or entitlement to more than twenty-five per cent. of shares or capital or profits of the company.
 - (bb) "Control" shall include the right to appoint majority of the directors or to control the management or policy decisions including by virtue of their shareholding of management rights or shareholder's agreements of voting agreements;

- (b) In case of a partnership firm, the beneficial owner is the natural person (s) who, whether acting alone or together, or through one or more juridical person, has ownership of entitlement to more than fifteen percent of capital or profits of the partnership;
- (c) In case of an unincorporated association or body of individuals, the beneficial owner is the natural person (s), who, whether acting alone or together, or through one or more juridical person, has ownership of or entitlement to more than fifteen percent of the property or capital or profits of such association or body of individuals;
- (d) Where no natural person is identified under (a) or (b) or (c) above, the beneficial owner is the relevant natural person who holds the position of senior managing official;
- (v) In case of a trust, the identification of beneficial owner (s) shall include identification of the author of the trust, the trustee, the beneficiaries with fifteen percent or more interest in the trust and any other natural person exercising ultimate effective control over the trust through a chain of control or ownership
- (vi) An Agent is a person employed to do any act for another, or to represent another in dealings with third person.
- (vii) The successful bidder shall not be allowed to sub-contract works to any contractor from a country which shares a land border with India unless such contractor is registered with the Competent Authority.

7.25 Progress Monitoring & Review Mechanism:

- (i) The Shipyard issuing the Progressive / Confirmation Contracts shall forward the copy to the Rate Contract issuing Shipyard for monitoring the quantum.
- (ii) On placement of order, the respective Defence Public Sector Shipyards will be monitoring the progress and performance of the vendor. In case of adverse observations, the same will be shared with the primary rate contract issuing Shipyard for taking suitable actions such as revoking the empanelment, tender holiday, etc.

7.26 Working on Defence Public Sector Shipyard Holidays:

Intimation for working on Saturday / Sunday / holidays if required, should be submitted 2 working days prior to the date of holiday indicating names of personnel to Personnel Department and Security through concerned Department.

7.27 In addition to above, following Terms & Conditions would be applicable to the empanelled contractors for executing the work as assigned.

- (i) GST terms & conditions (**Annexure-5**)
- (ii) General Conditions of Contract (GCC) for Goods and Services: **Annexure-6**
- (iii) Official Secret Act 1923: **Annexure-8**

8. Instruction to Bidders: Before submitting application (offer) against this EOI, bidders are requested to read the contents of the EOI document and Annexures, thoroughly & carefully. Deviations to the Terms & Conditions of the EOI are highly discouraged. Therefore, any doubts arising in respect of any of the Terms & Conditions stipulated, Qualification Criteria, clarification if any w.r.t. Documentation / Procedural requirements, etc. shall get clarified by the prospective bidder through the Dealing Executive invariably before the submission of their offer.

9. Submission of response / offer:

9.1 Submission of response to EOI: The bidders are required to submit their offer in the prescribed format as per **Annexure-2** on NIC e-procurement portal only. Offer in any other form will not be considered. The bid shall contain the following:

- (i) Acceptance of all the terms & conditions of EOI in the prescribed Format (**Annexure-13**)

- (ii) Acceptance of General conditions of contract (GCC) for Goods and Services **(Annexure-7)** The above documents shall be; duly stamped, signed & filled 'Accepted OR Not Accepted' as applicable for each of the clause. Normally deviations to the tender terms are discouraged. However, if the bidder has any deviations, the same should be filled in above formats mentioning the deviation against the relevant Tender clause no., failing which it will be construed that all clauses of this inquiry, GCC appearing against the EOI are understood by you and are fully acceptable to you.
 - (iii) Application for which type of supply Category applied for. **(Annexure-2)**
 - (iv) Details of Technical Pre-Qualification Criteria / previous experience **(Annexure-3)**
 - (v) Company Profile with supporting documents **(Annexure-4)**
 - (vi) Declaration by bidder for Restrictions under rule 144(xi) of general financial rules GFRs, (2017) **(Annexure-10)**
 - (vii) RTGS/ NEFT - Mandate Authorization Form **(Annexure-14)**
 - (viii) Declaration of Local Content **(Annexure-15)**
 - (ix) Bid Security Declaration **(Annexure-16)**
- 10. Bid Modification:** Modification in bids, if any, is to be made by bidders prior to the Eoi closing date & time.
- 11. Processing of Response / Offers to Eoi:**
- 11.1 All the offers received on or before EOI closing date & time will be scrutinized by Defence Public Sector Shipyards and credentials of the vendors will be verified including their competency. The applications which are finally selected for shortlisting for limited tenders will be intimated to the concerned firms.
- 12. Breach of Obligation with respect to Bid Submitted:** In case of breach of any obligation mentioned under, the bidder shall be disqualified / debarred from the empanelment process for a period of one year from the date of notification.
- (i) Bidder fails or refuses to execute the contract upon issuance of Rate Contract / Progressive Contracts by Purchaser by the Defence Public Sector Shipyards.
- 13. Public Grievance Cell:**
- Public Grievance Cell: A public grievance cell headed by Shri R. R. Kumar, ED (EY) has been set up in the company. Members of public having complaints or grievances are advised to contact above Authorities on Wednesday between 10.00 hours and 12.30 hours in his office at 3rd Floor, West Block, Mazagon Dock Shipbuilders Ltd or send their complaints / grievances to him in writing for redressal. Telephone No. is 23762106(MDL).
- 14. Book Examination Clause (BEC):**
- In case it is found to the satisfaction of MDL that the Supplier has engaged an Agent or paid commission or influenced any person to obtain the contract as described in clauses relating to Agents/Agency Commission and penalty for use of undue influence, the supplier, on a specific request of Defence Public Sector Shipyards shall provide necessary information/inspection of the relevant financial documents/information.
- 15. Validity Period of Offer:**
- (a) Bid / Offer shall have the validity period of 120 days after the deadline date for bid / response submission.
 - (b) Technically accepted bidder shall be given opportunity to accept validity as per the tender/Eoi in case of shorter validity quoted by him. Non acceptance there after shall be rejected by Defence Public Sector Shipyards as non-responsive.

(c) In case the day up to which the bids are to remain valid falls on/ subsequently declared a holiday or closed day for Defence Public Sector Shipyards, the bid validity shall automatically be deemed to be extended up to the next working day.

16. Bid Security Declaration :

Bidders shall submit EMD / Bid Security in the form of the Bid Security Declaration Format. It is mandatory to submit the Bid Security Declaration along with the Bid. Bidders not submitting the BID Security Declaration shall be liable for rejection.

17. Bid Security (EMD):

There is no Bid Security fee applicable for this EoI.

18. Parallel Rate Contracts:

(i) The Defence Public Sector Shipyards (MDL / GRSE / HSL / GSL) also reserves the rights (1) to enter into Rate Contract(s) / Parallel Price Agreement(s) / Contract(s) simultaneously or at any time during the period of the Price Agreement / Rate Contract with one or more bidder(s) as he/they think fit and (2) to place adhoc contract or contracts simultaneously or at any time during the period of this Rate contract with one or more supplier(s) / bidder(s) for such quantity of such item or items as the Defence Public Sector Shipyards (MDL / GRSE / HSL / GSL) (whose decision shall be final) may determine.

19. Right to Reject any or all Bids:

The Defence Public Sector Shipyards (MDL / GRSE / HSL / GSL) reserves its right to accept or reject any or all Bids, abandon/ cancel the Tender process, and issue another tender for the same or similar Goods/Services at any time before the award of the contract. It would have no liability to the affected Bidder or Bidders or any obligation to inform the affected Bidder or Bidders of the grounds for such action(s).

20. Warning Clause: It may please be noted that the Defence Public Sector Shipyards (MDL / GRSE / HSL / GSL) executing the defence orders for nation building as per the defence strategic plans focusing on the advanced security amour in place with state of art facility. Hence the orders placed / concluded by this organization has direct impact on the Defence strategic plans. Therefore, execution of the orders/contracts of Defence Public Sector Shipyards (MDL / GRSE / HSL / GSL) as per the techno-commercial terms and conditions therein are required to be strictly followed and abided with. It may be noted that any conduct of any conduct of grabbing the order and not executing may lead to be construed as deliberate efforts to affect the defence strategic plans, which comes under the periphery of betrayal to the Nation. This may further lead to breaching of laws relevant to causing threat to National security and accordingly the proceedings can be initiated against such unscrupulous bidders. Therefore, the bidders should take utmost precautions and measures before submitting the bid/offer. After placement of order no other deviation/excuses will be entertained and stringent action will be taken.

21. RISK PURCHASE:

If L1 or any other parties' defaults (fails to deliver goods on time) then the Defence Public Sector Shipyards (MDL / GRSE / HSL / GSL) reserves the right to purchase the goods from an alternate supplier or from market at the risk and cost of L1 supplier and if the purchase happens at a price higher than the ordered rates, the purchaser shall have the right to claim the difference upon whom order was originally placed and L1 supplier will be under obligation to pay the same. In addition, the purchaser is entitled to recover the business loss suffered by the purchaser consequent to default for supplying the product.

22. Conflict of Interest: Bidders having a conflict of interest shall not be eligible to participate in the tender process unless the conflict stemming from such relationship has been resolved in a manner acceptable to the Procuring Entity throughout the Tender process and execution of the Contract. The bidder shall

be considered to have a conflict of interest in this tender process and execution of the resultant contract in the following situations:-

(i) If its personnel have a close personal, financial, or business relationship with any personnel of the procuring entity who are directly or indirectly related to the procurement or execution process of the contract, which can affect the decision of the procuring entity directly or indirectly;

(ii) The bidder (or his allied firm) provided services for the need assessment/ procurement planning of the Tender process in which it is participating;

(iii) A Principal can authorize only one agent, and an agent should not represent or quote on behalf of more than one Principal. However, this shall not debar more than one Authorised distributor (with/ or without the OEM) from quoting equipment manufactured by an Original Equipment Manufacturer (OEM) in procurements under a Proprietary Article Certificate or

(iv) A bidder participates in more than one bid in this tender process. Participation in any capacity by a Bidder (including the participation of a Bidder as a partner/ JV member or sub-contractor in another bid or vice-versa) in more than one bid shall result in the disqualification of all bids in which he is a party. However, this does not limit the participation of an entity as a sub-contractor in more than one bid if he is not bidding independently in his own name or as a member of a JV;

23. Corrigendum to EoI / Tender Document: Before the deadline for submitting bids, Defence Public Sector Shipyards (MDL / GRSE / HSL / GSL) may update, amend, modify, or supplement the information, assessment or assumptions contained in the Tender/EoI Document by issuing a corrigendum. The corrigendum shall be published in the same manner as the original Tender/EoI Document. Without any liability or obligation, the Portal may send intimation of such corrigendum to bidders who have downloaded the document under their login. However, the bidders' responsibility is to check the website(s) for any corrigendum. Any corrigendum thus issued shall be considered a part of the Tender/EoI Document. To give reasonable time to the prospective bidders to take such corrigendum into account in preparing their bids, Defence Public Sector Shipyards (MDL / GRSE / HSL / GSL) may suitably extend the deadline for the bid submission, as necessary. After Defence Public Sector Shipyards (MDL / GRSE / HSL / GSL) makes such modifications, any Bidder who has submitted his bid in response to the original invitation shall have the opportunity to either withdraw his bid or re-submit his bid superseding the original bid within the extended time of submission.

24. E-Portal and E-Tender Guidance:

Submission of bids against e-Tenders: The bidder is required to quote online on the e-Procurement website www.eprocuremdl.nic.in by the deadline, by submitting the Techno-commercial Bid & Price Bid in Electronic format only. The prices/quotes & a few declarations shall have to be entered/uploaded by the bidder online in the Tender's entry forms & other bid documents scanned/soft copies shall have to be uploaded as part of the bid. All bids should be digitally signed using DSC (as explained below).

To participate in e-Tender (s), every bidder must register themselves on the ASP's website (registration is free of cost) & must possess a legally valid Class-IIB or above Digital Signature Certificate (DSC) as per IT Act-2000, using which they can sign their electronic bids. The DSC can be procured from any Certifying Authority (CA) authorized by Controller of Certifying Authorities (CCA) of Govt. of India.

National Informatics Centre (NIC) have been appointed by Defence Public Sector Shipyards (MDL / GRSE / HSL / GSL) as the Application Service Provider (ASP).

Online User Manual is available on the website for the guidance of users & for participating in the e-Procurement/ e-Tendering, the bidder must ensure having the requisite (IT) infrastructure at their office premises.

For any further details of e tendering & digital signatures, please contact 0120- 4001002, 0120-4711508, 0120-4001005, 0120-6277787.

Problems in hardware/software, internet connectivity, system configurations, Browser setting etc., for whatsoever reason shall not be considered for extension of tender closing date and time.

Defence Public Sector Shipyards (MDL / GRSE / HSL / GSL) will not be responsible for an error in downloading of tender documents from web by the bidders. The version appearing on e-procurement website will be considered final and authentic.

Entire responsibility of the uploading the complete offer against EoI along with all relevant documents shall be that of the bidder.

No request / complaint shall be entertained after the due date/time of the EoI.

Non availability of any of the prerequisites or last-minute calls seeking clarifications / projecting problems shall not entitle a bidder to seek request for extension of due date.

Any problem with regard to uploading of the tender shall be intimated to service provider at least 24 hours in advance to the tender closing time & date. However, it will not be considered as reason for extension of due date of the tender.

Request for extension, if at all to be made, shall be forwarded at least 3 working days in advance to the EoI closing date and time with proper reasoning by e-mail to MDL. The request shall be put up to the competent authority for consideration on the merit of the case. MDL reserves all rights in this regard & decision of MDL shall be binding to the applicants.

It is important to note that the bidders can upload their offer to EoI right from the time of EoI publishing date and time. It is advisable that the bidder uploads their offer well in time rather than wait till last minute to avoid situations wherein they are unable to successfully upload their offer for unforeseen reasons which cannot be addressed due to time limitation.

Bids received after EoI Closing date and time will not be considered.

- 25. Contact Details for Queries:** All bidders are requested to get their queries, if any, clarified in advance (i.e., 7 days in advance to EoI closing date) to avoid last minute delay. In case of any clarifications regarding tender, bidders are requested to contact the following executives:

Department	Shipyards	Name of Executives	Contact No	Email
Technical	MDL	Mr G K Rao	+91 22 23763035	gk Rao@mazdock.com
	GRSE	Mr Tanunoy Mukherjee	+91 9051376465	Mukherjee.Tanumoy@grse.co.in
	HSL	Mr Rajakrishna	+91 9493792408	rajakrishna.k316@hslvizag.com
	GSL	Mr Rayson Botelho	+91 9822930841	raysonbotelho@goashipyard.com
Commercial	MDL	Mr J Kumaran	+912223763250	itpurchase@mazdock.com
	GRSE	Mr Sujit Kumar Naskar	7603056564	Naskar.SujitKumar@grse.co.in
	HSL	Mr Bhanu Kiran	+91 9493792257	bhanukiran.k596@hslvizag.in
	GSL	Mr Manoj Shetgaonkar	+91 9881879084	manojshetgaonkar@goashipyard.com
Vendor Registration	MDL	Mr P K Roy	+912223763253	srr@mazdock.com
	GRSE	Mr M. Mahendran	03324893426	M.Mahendran@grse.co.in
	HSL	Lt Cdr Devina Sanyal	+91 9493792301	vendorregistration@hslvizag.com
	GSL	Mrs S Premlatha	+91 9423819888	spremlatha@goashipyard.com

- 26.** We look forward to receive your positive response to this EOI with the documents complete in all respect as requested in prescribed formats.

27. Submission of Response:

The response to the EoI shall be submitted only through NIC e-procurement portal. Response through any other mode shall be summarily rejected.

Yours faithfully,
For Mazagon Dock Shipbuilders Limited,

CM(Material)

Encl.:

Annexure-1	Scope of work
Annexure-2	Format for submission of application form
Annexure-3	Previous Experience
Annexure-4	Company Profile Format
Annexure-5	GST terms & conditions
Annexure-6	General Conditions of Contract (GCC) for Goods and Services.
Annexure-7	GCC Acceptance Format
Annexure-8	Official Secret Act 1923
Annexure-9	Contract Performance Security format
Annexure-10	Compliance Certificate w.r.t. Land Border Clause
Annexure-11	Integrity Pact
Annexure-12	Non-Disclosure Agreement
Annexure-13	EOI Acceptance Format
Annexure-14	RTGS/ NEFT - Mandate Authorization Form
Annexure-15	Declaration of Local Content
Annexure-16	Bid Security Declaration Format
Annexure-17	Drawings: DPSU-STD-DBH-STA-CST-PN010 & DPSU-STD-DBH-BUS-CNI-PN010 dated 10 Feb 2026; DPSU-STD-DBH-PAD-CNI-PN010 Rev 1 dated 24.03.2026

List of Items required to be Supplied

Sr No	Description	Tentative Qty for 3 Yrs (Mtrs)
Carbon Steel Pipes		
1	Pipe, Carbon Steel, 10 NB, 17.1 OD, Sch. 40, 2.31 mm thk., As per ASTM A 106 Gr. B & ANSI B 36.10. Seamless, Standard Length 6 Mtrs, +/-1 Mtrs Tolerance. All other dimensional tolerances shall be as per ANSI B 36.10. To be supplied with (i) MTC (Material, Dimensional & Testing). (ii) Bearing heat marks on each length at one end with tracability to MTC. Both ends to be suitably blanked. (iii) Pipes shall be non-galvanised (iv) Pipes to be externally coated with primer. (v) Pipes should be suitable for hot bending, cold bending, machine bending & collar formation. If any defects arise during fabrication, the pipe length to be replaced free of cost.	1200
2	Pipe, Carbon Steel, 10 NB, 17.1 OD, Sch. 80, 3.2 mm thk., As per ASTM A 106 Gr. B & ANSI B 36.10. Seamless, Standard Length 6 Mtrs, +/-1 Mtrs Tolerance. All other dimensional tolerances shall be as per ANSI B 36.10. To be supplied with (i) MTC (Material, Dimensional & Testing). (ii) Bearing heat marks on each length at one end with tracability to MTC. Both ends to be suitably blanked. (iii) Pipes shall be non-galvanised (iv) Pipes to be externally coated with primer. (v) Pipes should be suitable for hot bending, cold bending, machine bending & collar formation. If any defects arise during fabrication, the pipe length to be replaced free of cost.	24
3	Pipe, Carbon Steel, 100 NB, 114.3 OD, Sch. 40, 6.02 mm thk., As per ASTM A 106 Gr. B & ANSI B 36.10. Seamless, Standard Length 6 Mtrs, +/-1 Mtrs Tolerance. All other dimensional tolerances shall be as per ANSI B 36.10. To be supplied with (i) MTC (Material, Dimensional & Testing). (ii) Bearing heat marks on each length at one end with tracability to MTC. Both ends to be suitably blanked. (iii) Pipes shall be non-galvanised (iv) Pipes to be externally coated with primer. (v) Pipes should be suitable for hot bending, cold bending, machine bending & collar formation. If any defects arise during fabrication, the pipe length to be replaced free of cost.	4856
4	Pipe, Carbon Steel, 100 NB, 114.3 OD, Sch. 80, 8.56 mm thk., As per ASTM A 106 Gr. B & ANSI B 36.10. Seamless, Standard Length 6 Mtrs, +/-1 Mtrs Tolerance. All other dimensional tolerances shall be as per ANSI B 36.10. To be supplied with (i) MTC (Material, Dimensional & Testing). (ii) Bearing heat marks on each length at one end with tracability to MTC. Both ends to be suitably blanked. (iii) Pipes shall be non-galvanised (iv) Pipes to be externally coated with primer. (v) Pipes should be suitable for hot bending, cold bending, machine	750

Sr No	Description	Tentative Qty for 3 Yrs (Mtrs)
	bending & collar formation. If any defects arise during fabrication, the pipe length to be replaced free of cost.	
5	<p>Pipe, Carbon Steel, 125 NB, 141.3 OD, Sch. 40, 6.55 mm thk., As per ASTM A 106 Gr. B & ANSI B 36.10. Seamless, Standard Length 6 Mtrs, +/-1 Mtrs Tolerance. All other dimensional tolerances shall be as per ANSI B 36.10. To be supplied with</p> <p>(i) MTC (Material, Dimensional & Testing). (ii) Bearing heat marks on each length at one end with tracability to MTC. Both ends to be suitably blanked. (iii) Pipes shall be non-galvanised (iv) Pipes to be externally coated with primer. (v) Pipes should be suitable for hot bending, cold bending, machine bending & collar formation. If any defects arise during fabrication, the pipe length to be replaced free of cost.</p>	3716
6	<p>Pipe, Carbon Steel, 125 NB, 141.3 OD, Sch. 80, 9.53 mm thk., As per ASTM A 106 Gr. B & ANSI B 36.10. Seamless, Standard Length 6 Mtrs, +/-1 Mtrs Tolerance. All other dimensional tolerances shall be as per ANSI B 36.10. To be supplied with</p> <p>(i) MTC (Material, Dimensional & Testing). (ii) Bearing heat marks on each length at one end with tracability to MTC. Both ends to be suitably blanked. (iii) Pipes shall be non-galvanised (iv) Pipes to be externally coated with primer. (v) Pipes should be suitable for hot bending, cold bending, machine bending & collar formation. If any defects arise during fabrication, the pipe length to be replaced free of cost.</p>	1080
7	<p>Pipe, Carbon Steel, 15 NB, 21.3 OD, Sch. 40, 2.77 mm thk., As per ASTM A 106 Gr. B & ANSI B 36.10. Seamless, Standard Length 6 Mtrs, +/-1 Mtrs Tolerance. All other dimensional tolerances shall be as per ANSI B 36.10. To be supplied with</p> <p>(i) MTC (Material, Dimensional & Testing). (ii) Bearing heat marks on each length at one end with tracability to MTC. Both ends to be suitably blanked. (iii) Pipes shall be non-galvanised (iv) Pipes to be externally coated with primer. (v) Pipes should be suitable for hot bending, cold bending, machine bending & collar formation. If any defects arise during fabrication, the pipe length to be replaced free of cost.</p>	1483
8	<p>Pipe, Carbon Steel, 15 NB, 21.3 OD, Sch. 80, 3.73 mm thk., As per ASTM A 106 Gr. B & ANSI B 36.10. Seamless, Standard Length 6 Mtrs, +/-1 Mtrs Tolerance. All other dimensional tolerances shall be as per ANSI B 36.10. To be supplied with</p> <p>(i) MTC (Material, Dimensional & Testing). (ii) Bearing heat marks on each length at one end with tracability to MTC. Both ends to be suitably blanked. (iii) Pipes shall be non-galvanised (iv) Pipes to be externally coated with primer. (v) Pipes should be suitable for hot bending, cold bending, machine bending & collar formation. If any defects arise during fabrication, the pipe length to be replaced free of cost.</p>	250

Sr No	Description	Tentative Qty for 3 Yrs (Mtrs)
9	<p>Pipe, Carbon Steel, 150 NB, 168.3 OD, Sch. 40, 7.11 mm thk., As per ASTM A 106 Gr. B & ANSI B 36.10. Seamless, Standard Length 6 Mtrs, +/-1 Mtrs Tolerance. All other dimensional tolerances shall be as per ANSI B 36.10. To be supplied with</p> <p>(i) MTC (Material, Dimensional & Testing). (ii) Bearing heat marks on each length at one end with tracability to MTC. Both ends to be suitably blanked. (iii) Pipes shall be non-galvanised (iv) Pipes to be externally coated with primer. (v) Pipes should be suitable for hot bending, cold bending, machine bending & collar formation. If any defects arise during fabrication, the pipe length to be replaced free of cost.</p>	2492
10	<p>Pipe, Carbon Steel, 150 NB, 168.3 OD, Sch. 80, 10.97 mm thk., As per ASTM A 106 Gr. B & ANSI B 36.10. Seamless, Standard Length 6 Mtrs, +/-1 Mtrs Tolerance. All other dimensional tolerances shall be as per ANSI B 36.10. To be supplied with</p> <p>(i) MTC (Material, Dimensional & Testing). (ii) Bearing heat marks on each length at one end with tracability to MTC. Both ends to be suitably blanked. (iii) Pipes shall be non-galvanised (iv) Pipes to be externally coated with primer. (v) Pipes should be suitable for hot bending, cold bending, machine bending & collar formation. If any defects arise during fabrication, the pipe length to be replaced free of cost.</p>	284
11	<p>Pipe, Carbon Steel, 20 NB, 26.7 OD, Sch. 40, 2.87 mm thk., As per ASTM A 106 Gr. B & ANSI B 36.10. Seamless, Standard Length 6 Mtrs, +/-1 Mtrs Tolerance. All other dimensional tolerances shall be as per ANSI B 36.10. To be supplied with</p> <p>(i) MTC (Material, Dimensional & Testing). (ii) Bearing heat marks on each length at one end with tracability to MTC. Both ends to be suitably blanked. (iii) Pipes shall be non-galvanised (iv) Pipes to be externally coated with primer. (v) Pipes should be suitable for hot bending, cold bending, machine bending & collar formation. If any defects arise during fabrication, the pipe length to be replaced free of cost.</p>	2383
12	<p>Pipe, Carbon Steel, 20 NB, 26.7 OD, Sch. 80, 3.91 mm thk., As per ASTM A 106 Gr. B & ANSI B 36.10. Seamless, Standard Length 6 Mtrs, +/-1 Mtrs Tolerance. All other dimensional tolerances shall be as per ANSI B 36.10. To be supplied with</p> <p>(i) MTC (Material, Dimensional & Testing). (ii) Bearing heat marks on each length at one end with tracability to MTC. Both ends to be suitably blanked. (iii) Pipes shall be non-galvanised (iv) Pipes to be externally coated with primer. (v) Pipes should be suitable for hot bending, cold bending, machine bending & collar formation. If any defects arise during fabrication, the pipe length to be replaced free of cost.</p>	120
13	<p>Pipe, Carbon Steel, 25 NB, 33.4 OD, Sch. 40, 3.38 mm thk., As per ASTM A 106 Gr. B & ANSI B 36.10. Seamless, Standard Length 6 Mtrs, +/-1 Mtrs Tolerance. All other dimensional tolerances shall be as per ANSI B 36.10.</p>	5138

Sr No	Description	Tentative Qty for 3 Yrs (Mtrs)
	<p>To be supplied with</p> <p>(i) MTC (Material, Dimensional & Testing).</p> <p>(ii) Bearing heat marks on each length at one end with tracability to MTC. Both ends to be suitably blanked.</p> <p>(iii) Pipes shall be non-galvanised</p> <p>(iv) Pipes to be externally coated with primer.</p> <p>(v) Pipes should be suitable for hot bending, cold bending, machine bending & collar formation. If any defects arise during fabrication, the pipe length to be replaced free of cost.</p>	
14	<p>Pipe, Carbon Steel, 25 NB, 33.4 OD, Sch. 80, 4.55 mm thk., As per ASTM A 106 Gr. B & ANSI B 36.10. Seamless, Standard Length 6 Mtrs, +/-1 Mtrs Tolerance. All other dimensional tolerances shall be as per ANSI B 36.10.</p> <p>To be supplied with</p> <p>(i) MTC (Material, Dimensional & Testing).</p> <p>(ii) Bearing heat marks on each length at one end with tracability to MTC. Both ends to be suitably blanked.</p> <p>(iii) Pipes shall be non-galvanised</p> <p>(iv) Pipes to be externally coated with primer.</p> <p>(v) Pipes should be suitable for hot bending, cold bending, machine bending & collar formation. If any defects arise during fabrication, the pipe length to be replaced free of cost.</p>	350
15	<p>Pipe, Carbon Steel, 32 NB, 42.2 OD, Sch. 40, 3.56 mm thk., As per ASTM A 106 Gr. B & ANSI B 36.10. Seamless, Standard Length 6 Mtrs, +/-1 Mtrs Tolerance. All other dimensional tolerances shall be as per ANSI B 36.10.</p> <p>To be supplied with</p> <p>(i) MTC (Material, Dimensional & Testing).</p> <p>(ii) Bearing heat marks on each length at one end with tracability to MTC. Both ends to be suitably blanked.</p> <p>(iii) Pipes shall be non-galvanised</p> <p>(iv) Pipes to be externally coated with primer.</p> <p>(v) Pipes should be suitable for hot bending, cold bending, machine bending & collar formation. If any defects arise during fabrication, the pipe length to be replaced free of cost.</p>	4767
16	<p>Pipe, Carbon Steel, 32 NB, 42.2 OD, Sch. 80, 4.85 mm thk., As per ASTM A 106 Gr. B & ANSI B 36.10. Seamless, Standard Length 6 Mtrs, +/-1 Mtrs Tolerance. All other dimensional tolerances shall be as per ANSI B 36.10.</p> <p>To be supplied with</p> <p>(i) MTC (Material, Dimensional & Testing).</p> <p>(ii) Bearing heat marks on each length at one end with tracability to MTC. Both ends to be suitably blanked.</p> <p>(iii) Pipes shall be non-galvanised</p> <p>(iv) Pipes to be externally coated with primer.</p> <p>(v) Pipes should be suitable for hot bending, cold bending, machine bending & collar formation. If any defects arise during fabrication, the pipe length to be replaced free of cost.</p>	1632
17	<p>Pipe, Carbon Steel, 40 NB, 48.3 OD, Sch. 40, 3.68 mm thk., As per ASTM A 106 Gr. B & ANSI B 36.10. Seamless, Standard Length 6 Mtrs, +/-1 Mtrs Tolerance. All other dimensional tolerances shall be as per ANSI B 36.10.</p> <p>To be supplied with</p> <p>(i) MTC (Material, Dimensional & Testing).</p> <p>(ii) Bearing heat marks on each length at one end with tracability to MTC.</p>	16954

Sr No	Description	Tentative Qty for 3 Yrs (Mtrs)
	Both ends to be suitably blanked. (iii) Pipes shall be non-galvanised (iv) Pipes to be externally coated with primer. (v) Pipes should be suitable for hot bending, cold bending, machine bending & collar formation. If any defects arise during fabrication, the pipe length to be replaced free of cost.	
18	Pipe, Carbon Steel, 40 NB, 48.3 OD, Sch. 80, 5.08 mm thk., As per ASTM A 106 Gr. B & ANSI B 36.10. Seamless, Standard Length 6 Mtrs, +/-1 Mtrs Tolerance. All other dimensional tolerances shall be as per ANSI B 36.10. To be supplied with (i) MTC (Material, Dimensional & Testing). (ii) Bearing heat marks on each length at one end with tracability to MTC. Both ends to be suitably blanked. (iii) Pipes shall be non-galvanised (iv) Pipes to be externally coated with primer. (v) Pipes should be suitable for hot bending, cold bending, machine bending & collar formation. If any defects arise during fabrication, the pipe length to be replaced free of cost.	1902
19	Pipe, Carbon Steel, 50 NB, 60.3 OD, Sch. 40, 3.91 mm thk., As per ASTM A 106 Gr. B & ANSI B 36.10. Seamless, Standard Length 6 Mtrs, +/-1 Mtrs Tolerance. All other dimensional tolerances shall be as per ANSI B 36.10. To be supplied with (i) MTC (Material, Dimensional & Testing). (ii) Bearing heat marks on each length at one end with tracability to MTC. Both ends to be suitably blanked. (iii) Pipes shall be non-galvanised (iv) Pipes to be externally coated with primer. (v) Pipes should be suitable for hot bending, cold bending, machine bending & collar formation. If any defects arise during fabrication, the pipe length to be replaced free of cost.	21447
20	Pipe, Carbon Steel, 50 NB, 60.3 OD, Sch. 80, 5.54 mm thk., As per ASTM A 106 Gr. B & ANSI B 36.10. Seamless, Standard Length 6 Mtrs, +/-1 Mtrs Tolerance. All other dimensional tolerances shall be as per ANSI B 36.10. To be supplied with (i) MTC (Material, Dimensional & Testing). (ii) Bearing heat marks on each length at one end with tracability to MTC. Both ends to be suitably blanked. (iii) Pipes shall be non-galvanised (iv) Pipes to be externally coated with primer. (v) Pipes should be suitable for hot bending, cold bending, machine bending & collar formation. If any defects arise during fabrication, the pipe length to be replaced free of cost.	4736
21	Pipe, Carbon Steel, 6 NB, 13.7 OD, Sch. 40, 1.73 mm thk., As per ASTM A 106 Gr. B & ANSI B 36.10. Seamless, Standard Length 6 Mtrs, +/-1 Mtrs Tolerance. All other dimensional tolerances shall be as per ANSI B 36.10. To be supplied with (i) MTC (Material, Dimensional & Testing). (ii) Bearing heat marks on each length at one end with tracability to MTC. Both ends to be suitably blanked. (iii) Pipes shall be non-galvanised (iv) Pipes to be externally coated with primer.	336

Sr No	Description	Tentative Qty for 3 Yrs (Mtrs)
	(v) Pipes should be suitable for hot bending, cold bending, machine bending & collar formation. If any defects arise during fabrication, the pipe length to be replaced free of cost.	
22	Pipe, Carbon Steel, 6 NB, 13.7 OD, Sch. 80, 2.41 mm thk., As per ASTM A 106 Gr. B & ANSI B 36.10. Seamless, Standard Length 6 Mtrs, +/-1 Mtrs Tolerance. All other dimensional tolerances shall be as per ANSI B 36.10. To be supplied with (i) MTC (Material, Dimensional & Testing). (ii) Bearing heat marks on each length at one end with tracability to MTC. Both ends to be suitably blanked. (iii) Pipes shall be non-galvanised (iv) Pipes to be externally coated with primer. (v) Pipes should be suitable for hot bending, cold bending, machine bending & collar formation. If any defects arise during fabrication, the pipe length to be replaced free of cost.	0
23	Pipe, Carbon Steel, 65 NB, 73 OD, Sch. 40, 5.16 mm thk., As per ASTM A 106 Gr. B & ANSI B 36.10. Seamless, Standard Length 6 Mtrs, +/-1 Mtrs Tolerance. All other dimensional tolerances shall be as per ANSI B 36.10. To be supplied with (i) MTC (Material, Dimensional & Testing). (ii) Bearing heat marks on each length at one end with tracability to MTC. Both ends to be suitably blanked. (iii) Pipes shall be non-galvanised (iv) Pipes to be externally coated with primer. (v) Pipes should be suitable for hot bending, cold bending, machine bending & collar formation. If any defects arise during fabrication, the pipe length to be replaced free of cost.	13380
24	Pipe, Carbon Steel, 65 NB, 73 OD, Sch. 80, 7.01 mm thk., As per ASTM A 106 Gr. B & ANSI B 36.10. Seamless, Standard Length 6 Mtrs, +/-1 Mtrs Tolerance. All other dimensional tolerances shall be as per ANSI B 36.10. To be supplied with (i) MTC (Material, Dimensional & Testing). (ii) Bearing heat marks on each length at one end with tracability to MTC. Both ends to be suitably blanked. (iii) Pipes shall be non-galvanised (iv) Pipes to be externally coated with primer. (v) Pipes should be suitable for hot bending, cold bending, machine bending & collar formation. If any defects arise during fabrication, the pipe length to be replaced free of cost.	1544
25	Pipe, Carbon Steel, 80 NB, 88.9 OD, Sch. 40, 5.49 mm thk., As per ASTM A 106 Gr. B & ANSI B 36.10. Seamless, Standard Length 6 Mtrs, +/-1 Mtrs Tolerance. All other dimensional tolerances shall be as per ANSI B 36.10. To be supplied with (i) MTC (Material, Dimensional & Testing). (ii) Bearing heat marks on each length at one end with tracability to MTC. Both ends to be suitably blanked. (iii) Pipes shall be non-galvanised (iv) Pipes to be externally coated with primer. (v) Pipes should be suitable for hot bending, cold bending, machine bending & collar formation. If any defects arise during fabrication, the pipe length to be replaced free of cost.	10250

Sr No	Description	Tentative Qty for 3 Yrs (Mtrs)
26	Pipe, Carbon Steel, 80 NB, 88.9 OD, Sch. 80, 7.62 mm thk., As per ASTM A 106 Gr. B & ANSI B 36.10. Seamless, Standard Length 6 Mtrs, +/-1 Mtrs Tolerance. All other dimensional tolerances shall be as per ANSI B 36.10. To be supplied with (i) MTC (Material, Dimensional & Testing). (ii) Bearing heat marks on each length at one end with tracability to MTC. Both ends to be suitably blanked. (iii) Pipes shall be non-galvanised (iv) Pipes to be externally coated with primer. (v) Pipes should be suitable for hot bending, cold bending, machine bending & collar formation. If any defects arise during fabrication, the pipe length to be replaced free of cost.	4006
27	Pipe, Carbon Steel, 200 NB, 219.1 OD, Sch. 40, 8.18 mm thk., As per ASTM A 106 Gr. B & ANSI B 36.10. Seamless, Standard Length 6 Mtrs, +/-1 Mtrs Tolerance. All other dimensional tolerances shall be as per ANSI B 36.10. To be supplied with (i) MTC (Material, Dimensional & Testing). (ii) Bearing heat marks on each length at one end with tracability to MTC. Both ends to be suitably blanked. (iii) Pipes shall be non-galvanised (iv) Pipes to be externally coated with primer. (v) Pipes should be suitable for hot bending, cold bending, machine bending & collar formation. If any defects arise during fabrication, the pipe length to be replaced free of cost.	250
28	Pipe, Carbon Steel, 200 NB, 219.1 OD, Sch. 80, 12.7 mm thk., As per ASTM A 106 Gr. B & ANSI B 36.10. Seamless, Standard Length 6 Mtrs, +/-1 Mtrs Tolerance. All other dimensional tolerances shall be as per ANSI B 36.10. To be supplied with (i) MTC (Material, Dimensional & Testing). (ii) Bearing heat marks on each length at one end with tracability to MTC. Both ends to be suitably blanked. (iii) Pipes shall be non-galvanised (iv) Pipes to be externally coated with primer. (v) Pipes should be suitable for hot bending, cold bending, machine bending & collar formation. If any defects arise during fabrication, the pipe length to be replaced free of cost.	146
29	Pipe, Carbon Steel, 250 NB, 273 OD, Sch. 40, 9.27 mm thk., As per ASTM A 106 Gr. B & ANSI B 36.10. Seamless, Standard Length 6 Mtrs, +/-1 Mtrs Tolerance. All other dimensional tolerances shall be as per ANSI B 36.10. To be supplied with (i) MTC (Material, Dimensional & Testing). (ii) Bearing heat marks on each length at one end with tracability to MTC. Both ends to be suitably blanked. (iii) Pipes shall be non-galvanised (iv) Pipes to be externally coated with primer. (v) Pipes should be suitable for hot bending, cold bending, machine bending & collar formation. If any defects arise during fabrication, the pipe length to be replaced free of cost.	125
30	Pipe, Carbon Steel, 250 NB, 273 OD, Sch. 80, 12.7 mm thk., As per ASTM A 106 Gr. B & ANSI B 36.10. Seamless, Standard Length 6 Mtrs, +/-1 Mtrs Tolerance. All other dimensional tolerances shall be as per ANSI B 36.10.	120

Sr No	Description	Tentative Qty for 3 Yrs (Mtrs)
	To be supplied with (i) MTC (Material, Dimensional & Testing). (ii) Bearing heat marks on each length at one end with tracability to MTC. Both ends to be suitably blanked. (iii) Pipes shall be non-galvanised (iv) Pipes to be externally coated with primer. (v) Pipes should be suitable for hot bending, cold bending, machine bending & collar formation. If any defects arise during fabrication, the pipe length to be replaced free of cost.	
31	Pipe, Carbon Steel, 300 NB, 323.8 OD, Sch. 40, 10.31 mm thk., As per ASTM A 106 Gr. B & ANSI B 36.10. Seamless, Standard Length 6 Mtrs, +/-1 Mtrs Tolerance. All other dimensional tolerances shall be as per ANSI B 36.10. To be supplied with (i) MTC (Material, Dimensional & Testing). (ii) Bearing heat marks on each length at one end with tracability to MTC. Both ends to be suitably blanked. (iii) Pipes shall be non-galvanised (iv) Pipes to be externally coated with primer. (v) Pipes should be suitable for hot bending, cold bending, machine bending & collar formation. If any defects arise during fabrication, the pipe length to be replaced free of cost.	125
32	Pipe, Carbon Steel, 300 NB, 323.8 OD, Sch. 80, 12.7 mm thk., As per ASTM A 106 Gr. B & ANSI B 36.10. Seamless, Standard Length 6 Mtrs, +/-1 Mtrs Tolerance. All other dimensional tolerances shall be as per ANSI B 36.10. To be supplied with (i) MTC (Material, Dimensional & Testing). (ii) Bearing heat marks on each length at one end with tracability to MTC. Both ends to be suitably blanked. (iii) Pipes shall be non-galvanised (iv) Pipes to be externally coated with primer. (v) Pipes should be suitable for hot bending, cold bending, machine bending & collar formation. If any defects arise during fabrication, the pipe length to be replaced free of cost.	84

Sr No	Description	Tentative Qty for 3 Yrs (Mtrs)
	Copper Pipes	
33	Pipe, Copper, 6 NB, 10 OD, PN 10, 0.8 mm thk., As per C 106 grade as per BS 2871, Part II & (Equivalent to NES 837, Part III). Seamless, Standard Length 6 Mtrs, +/-1 Mtrs Tolerance. All other dimensional tolerances shall be as per BS 2871, Part II. To be supplied with (i) MTC (Material, Dimensional & Testing). (ii) Bearing heat marks on each length at one end with tracability to MTC. Both ends to be suitably blanked. (iii) Pipes to be supplied without any coating. (iv) Pipes should be suitable for hot bending, cold bending, machine bending & collar formation. If any defects arise during fabrication, the pipe length to be replaced free of cost.	650

Sr No	Description	Tentative Qty for 3 Yrs (Mtrs)
34	<p>Pipe, Copper, 10 NB, 16 OD, PN 10, 1 mm thk., As per C 106 grade as per BS 2871, Part II & (Equivalent to NES 837, Part III). Seamless, Standard Length 6 Mtrs, +/-1 Mtrs Tolerance. All other dimensional tolerances shall be as per BS 2871, Part II.</p> <p>To be supplied with</p> <p>(i) MTC (Material, Dimensional & Testing).</p> <p>(ii) Bearing heat marks on each length at one end with tracability to MTC. Both ends to be suitably blanked.</p> <p>(iii) Pipes to be supplied without any coating.</p> <p>(iv) Pipes should be suitable for hot bending, cold bending, machine bending & collar formation. If any defects arise during fabrication, the pipe length to be replaced free of cost.</p>	3725
35	<p>Pipe, Copper, 15 NB, 20 OD, PN 10, 1 mm thk., As per C 106 grade as per BS 2871, Part II & (Equivalent to NES 837, Part III). Seamless, Standard Length 6 Mtrs, +/-1 Mtrs Tolerance. All other dimensional tolerances shall be as per BS 2871, Part II.</p> <p>To be supplied with</p> <p>(i) MTC (Material, Dimensional & Testing).</p> <p>(ii) Bearing heat marks on each length at one end with tracability to MTC. Both ends to be suitably blanked.</p> <p>(iii) Pipes to be supplied without any coating.</p> <p>(iv) Pipes should be suitable for hot bending, cold bending, machine bending & collar formation. If any defects arise during fabrication, the pipe length to be replaced free of cost.</p>	2150
36	<p>Pipe, Copper, 20 NB, 25 OD, PN 10, 1.5 mm thk., As per C 106 grade as per BS 2871, Part II & (Equivalent to NES 837, Part III). Seamless, Standard Length 6 Mtrs, +/-1 Mtrs Tolerance. All other dimensional tolerances shall be as per BS 2871, Part II.</p> <p>To be supplied with</p> <p>(i) MTC (Material, Dimensional & Testing).</p> <p>(ii) Bearing heat marks on each length at one end with tracability to MTC. Both ends to be suitably blanked.</p> <p>(iii) Pipes to be supplied without any coating.</p> <p>(iv) Pipes should be suitable for hot bending, cold bending, machine bending & collar formation. If any defects arise during fabrication, the pipe length to be replaced free of cost.</p>	520
37	<p>Pipe, Copper, 25 NB, 30 OD, PN 10, 1.5 mm thk., As per C 106 grade as per BS 2871, Part II & (Equivalent to NES 837, Part III). Seamless, Standard Length 6 Mtrs, +/-1 Mtrs Tolerance. All other dimensional tolerances shall be as per BS 2871, Part II.</p> <p>To be supplied with</p> <p>(i) MTC (Material, Dimensional & Testing).</p> <p>(ii) Bearing heat marks on each length at one end with tracability to MTC. Both ends to be suitably blanked.</p> <p>(iii) Pipes to be supplied without any coating.</p> <p>(iv) Pipes should be suitable for hot bending, cold bending, machine bending & collar formation. If any defects arise during fabrication, the pipe length to be replaced free of cost.</p>	1850
38	<p>Pipe, Copper, 32 NB, 38 OD, PN 10, 1.5 mm thk., As per C 106 grade as per BS 2871, Part II & (Equivalent to NES 837, Part III). Seamless, Standard Length 6 Mtrs, +/-1 Mtrs Tolerance. All other dimensional tolerances shall</p>	568

Sr No	Description	Tentative Qty for 3 Yrs (Mtrs)
	<p>be as per BS 2871, Part II. To be supplied with</p> <ul style="list-style-type: none"> (i) MTC (Material, Dimensional & Testing). (ii) Bearing heat marks on each length at one end with tracability to MTC. Both ends to be suitably blanked. (iii) Pipes to be supplied without any coating. (iv) Pipes should be suitable for hot bending, cold bending, machine bending & collar formation. If any defects arise during fabrication, the pipe length to be replaced free of cost. 	
39	<p>Pipe, Copper, 40 NB, 44.5 OD, PN 10, 1.5 mm thk., As per C 106 grade as per BS 2871, Part II & (Equivalent to NES 837, Part III). Seamless, Standard Length 6 Mtrs, +/-1 Mtrs Tolerance. All other dimensional tolerances shall be as per BS 2871, Part II. To be supplied with</p> <ul style="list-style-type: none"> (i) MTC (Material, Dimensional & Testing). (ii) Bearing heat marks on each length at one end with tracability to MTC. Both ends to be suitably blanked. (iii) Pipes to be supplied without any coating. (iv) Pipes should be suitable for hot bending, cold bending, machine bending & collar formation. If any defects arise during fabrication, the pipe length to be replaced free of cost. 	1245
40	<p>Pipe, Copper, 50 NB, 57 OD, PN 10, 1.5 mm thk., As per C 106 grade as per BS 2871, Part II & (Equivalent to NES 837, Part III). Seamless, Standard Length 6 Mtrs, +/-1 Mtrs Tolerance. All other dimensional tolerances shall be as per BS 2871, Part II. To be supplied with</p> <ul style="list-style-type: none"> (i) MTC (Material, Dimensional & Testing). (ii) Bearing heat marks on each length at one end with tracability to MTC. Both ends to be suitably blanked. (iii) Pipes to be supplied without any coating. (iv) Pipes should be suitable for hot bending, cold bending, machine bending & collar formation. If any defects arise during fabrication, the pipe length to be replaced free of cost. 	1430
41	<p>Pipe, Copper, 65 NB, 76.1 OD, PN 10, 2 mm thk., As per C 106 grade as per BS 2871, Part II & (Equivalent to NES 837, Part III). Seamless, Standard Length 6 Mtrs, +/-1 Mtrs Tolerance. All other dimensional tolerances shall be as per BS 2871, Part II. To be supplied with</p> <ul style="list-style-type: none"> (i) MTC (Material, Dimensional & Testing). (ii) Bearing heat marks on each length at one end with tracability to MTC. Both ends to be suitably blanked. (iii) Pipes to be supplied without any coating. (iv) Pipes should be suitable for hot bending, cold bending, machine bending & collar formation. If any defects arise during fabrication, the pipe length to be replaced free of cost. 	3375
42	<p>Pipe, Copper, 80 NB, 88.9 OD, PN 10, 2.5 mm thk., As per C 106 grade as per BS 2871, Part II & (Equivalent to NES 837, Part III). Seamless, Standard Length 6 Mtrs, +/-1 Mtrs Tolerance. All other dimensional tolerances shall be as per BS 2871, Part II. To be supplied with</p> <ul style="list-style-type: none"> (i) MTC (Material, Dimensional & Testing). 	180

Sr No	Description	Tentative Qty for 3 Yrs (Mtrs)
	(ii) Bearing heat marks on each length at one end with tracability to MTC. Both ends to be suitably blanked. (iii) Pipes to be supplied without any coating. (iv) Pipes should be suitable for hot bending, cold bending, machine bending & collar formation. If any defects arise during fabrication, the pipe length to be replaced free of cost.	

Sr No	Description	Tentative Qty for 3 Yrs (Mtrs)
	90/10 Cu Ni Pipes	
43	Pipe, 90/10 Cu Ni, 6 NB, 10 OD, PN 10, 0.8 mm thk., As per CN 102 grade as per BS 2871, Part II & (Equivalent to NES 779, Part III). Seamless, Standard Length 6 Mtrs, +/-1 Mtrs Tolerance. All other dimensional tolerances shall be as per BS 2871, Part II. To be supplied with (i) MTC (Material, Dimensional & Testing). (ii) Bearing heat marks on each length at one end with tracability to MTC. Both ends to be suitably blanked. (iii) Pipes to be supplied without any coating. (iv) Pipes should be suitable for hot bending, cold bending, machine bending & collar formation. If any defects arise during fabrication, the pipe length to be replaced free of cost.	100
44	Pipe, 90/10 Cu Ni, 10 NB, 16 OD, PN 10, 1 mm thk., As per CN 102 grade as per BS 2871, Part II & (Equivalent to NES 779, Part III). Seamless, Standard Length 6 Mtrs, +/-1 Mtrs Tolerance. All other dimensional tolerances shall be as per BS 2871, Part II. To be supplied with (i) MTC (Material, Dimensional & Testing). (ii) Bearing heat marks on each length at one end with tracability to MTC. Both ends to be suitably blanked. (iii) Pipes to be supplied without any coating. (iv) Pipes should be suitable for hot bending, cold bending, machine bending & collar formation. If any defects arise during fabrication, the pipe length to be replaced free of cost.	950
45	Pipe, 90/10 Cu Ni, 15 NB, 20 OD, PN 10, 1 mm thk., As per CN 102 grade as per BS 2871, Part II & (Equivalent to NES 779, Part III). Seamless, Standard Length 6 Mtrs, +/-1 Mtrs Tolerance. All other dimensional tolerances shall be as per BS 2871, Part II. To be supplied with (i) MTC (Material, Dimensional & Testing). (ii) Bearing heat marks on each length at one end with tracability to MTC. Both ends to be suitably blanked. (iii) Pipes to be supplied without any coating. (iv) Pipes should be suitable for hot bending, cold bending, machine bending & collar formation. If any defects arise during fabrication, the pipe length to be replaced free of cost.	890
46	Pipe, 90/10 Cu Ni, 20 NB, 25 OD, PN 10, 1.5 mm thk., As per CN 102 grade as per BS 2871, Part II & (Equivalent to NES 779, Part III). Seamless, Standard Length 6 Mtrs, +/-1 Mtrs Tolerance. All other dimensional tolerances shall be as per BS 2871, Part II.	1152

Sr No	Description	Tentative Qty for 3 Yrs (Mtrs)
	<p>To be supplied with</p> <p>(i) MTC (Material, Dimensional & Testing).</p> <p>(ii) Bearing heat marks on each length at one end with tracability to MTC. Both ends to be suitably blanked.</p> <p>(iii) Pipes to be supplied without any coating.</p> <p>(iv) Pipes should be suitable for hot bending, cold bending, machine bending & collar formation. If any defects arise during fabrication, the pipe length to be replaced free of cost.</p>	
47	<p>Pipe, 90/10 Cu Ni, 25 NB, 30 OD, PN 10, 1.5 mm thk., As per CN 102 grade as per BS 2871, Part II & (Equivalent to NES 779, Part III). Seamless, Standard Length 6 Mtrs, +/-1 Mtrs Tolerance. All other dimensional tolerances shall be as per BS 2871, Part II.</p> <p>To be supplied with</p> <p>(i) MTC (Material, Dimensional & Testing).</p> <p>(ii) Bearing heat marks on each length at one end with tracability to MTC. Both ends to be suitably blanked.</p> <p>(iii) Pipes to be supplied without any coating.</p> <p>(iv) Pipes should be suitable for hot bending, cold bending, machine bending & collar formation. If any defects arise during fabrication, the pipe length to be replaced free of cost.</p>	2363
48	<p>Pipe, 90/10 Cu Ni, 32 NB, 38 OD, PN 10, 1.5 mm thk., As per CN 102 grade as per BS 2871, Part II & (Equivalent to NES 779, Part III). Seamless, Standard Length 6 Mtrs, +/-1 Mtrs Tolerance. All other dimensional tolerances shall be as per BS 2871, Part II.</p> <p>To be supplied with</p> <p>(i) MTC (Material, Dimensional & Testing).</p> <p>(ii) Bearing heat marks on each length at one end with tracability to MTC. Both ends to be suitably blanked.</p> <p>(iii) Pipes to be supplied without any coating.</p> <p>(iv) Pipes should be suitable for hot bending, cold bending, machine bending & collar formation. If any defects arise during fabrication, the pipe length to be replaced free of cost.</p>	2216
49	<p>Pipe, 90/10 Cu Ni, 40 NB, 44.5 OD, PN 10, 1.5 mm thk., As per CN 102 grade as per BS 2871, Part II & (Equivalent to NES 779, Part III). Seamless, Standard Length 6 Mtrs, +/-1 Mtrs Tolerance. All other dimensional tolerances shall be as per BS 2871, Part II.</p> <p>To be supplied with</p> <p>(i) MTC (Material, Dimensional & Testing).</p> <p>(ii) Bearing heat marks on each length at one end with tracability to MTC. Both ends to be suitably blanked.</p> <p>(iii) Pipes to be supplied without any coating.</p> <p>(iv) Pipes should be suitable for hot bending, cold bending, machine bending & collar formation. If any defects arise during fabrication, the pipe length to be replaced free of cost.</p>	2748
50	<p>Pipe, 90/10 Cu Ni, 50 NB, 57 OD, PN 10, 1.5 mm thk., As per CN 102 grade as per BS 2871, Part II & (Equivalent to NES 779, Part III). Seamless, Standard Length 6 Mtrs, +/-1 Mtrs Tolerance. All other dimensional tolerances shall be as per BS 2871, Part II.</p> <p>To be supplied with</p> <p>(i) MTC (Material, Dimensional & Testing).</p> <p>(ii) Bearing heat marks on each length at one end with tracability to MTC.</p>	2030

Sr No	Description	Tentative Qty for 3 Yrs (Mtrs)
	<p>Both ends to be suitably blanked.</p> <p>(iii) Pipes to be supplied without any coating.</p> <p>(iv) Pipes should be suitable for hot bending, cold bending, machine bending & collar formation. If any defects arise during fabrication, the pipe length to be replaced free of cost.</p>	
51	<p>Pipe, 90/10 Cu Ni, 65 NB, 76.1 OD, PN 10, 2 mm thk., As per CN 102 grade as per BS 2871, Part II & (Equivalent to NES 779, Part III). Seamless, Standard Length 6 Mtrs, +/-1 Mtrs Tolerance. All other dimensional tolerances shall be as per BS 2871, Part II.</p> <p>To be supplied with</p> <p>(i) MTC (Material, Dimensional & Testing).</p> <p>(ii) Bearing heat marks on each length at one end with tracability to MTC. Both ends to be suitably blanked.</p> <p>(iii) Pipes to be supplied without any coating.</p> <p>(iv) Pipes should be suitable for hot bending, cold bending, machine bending & collar formation. If any defects arise during fabrication, the pipe length to be replaced free of cost.</p>	7045
52	<p>Pipe, 90/10 Cu Ni, 80 NB, 88.9 OD, PN 10, 2.5 mm thk., As per CN 102 grade as per BS 2871, Part II & (Equivalent to NES 779, Part III). Seamless, Standard Length 6 Mtrs, +/-1 Mtrs Tolerance. All other dimensional tolerances shall be as per BS 2871, Part II.</p> <p>To be supplied with</p> <p>(i) MTC (Material, Dimensional & Testing).</p> <p>(ii) Bearing heat marks on each length at one end with tracability to MTC. Both ends to be suitably blanked.</p> <p>(iii) Pipes to be supplied without any coating.</p> <p>(iv) Pipes should be suitable for hot bending, cold bending, machine bending & collar formation. If any defects arise during fabrication, the pipe length to be replaced free of cost.</p>	2965
53	<p>Pipe, 90/10 Cu Ni, 100 NB, 108 OD, PN 10, 2.5 mm thk., As per CN 102 grade as per BS 2871, Part II & (Equivalent to NES 779, Part III). Seamless, Standard Length 6 Mtrs, +/-1 Mtrs Tolerance. All other dimensional tolerances shall be as per BS 2871, Part II.</p> <p>To be supplied with</p> <p>(i) MTC (Material, Dimensional & Testing).</p> <p>(ii) Bearing heat marks on each length at one end with tracability to MTC. Both ends to be suitably blanked.</p> <p>(iii) Pipes to be supplied without any coating.</p> <p>(iv) Pipes should be suitable for hot bending, cold bending, machine bending & collar formation. If any defects arise during fabrication, the pipe length to be replaced free of cost.</p>	4244
54	<p>Pipe, 90/10 Cu Ni, 125 NB, 133 OD, PN 10, 2.5 mm thk., As per CN 102 grade as per BS 2871, Part II & (Equivalent to NES 779, Part III). Seamless, Standard Length 6 Mtrs, +/-1 Mtrs Tolerance. All other dimensional tolerances shall be as per BS 2871, Part II.</p> <p>To be supplied with</p> <p>(i) MTC (Material, Dimensional & Testing).</p> <p>(ii) Bearing heat marks on each length at one end with tracability to MTC. Both ends to be suitably blanked.</p> <p>(iii) Pipes to be supplied without any coating.</p> <p>(iv) Pipes should be suitable for hot bending, cold bending, machine</p>	2337

Sr No	Description	Tentative Qty for 3 Yrs (Mtrs)
	bending & collar formation. If any defects arise during fabrication, the pipe length to be replaced free of cost.	
55	<p>Pipe, 90/10 Cu Ni, 150 NB, 159 OD, PN 10, 2.5 mm thk., As per CN 102 grade as per BS 2871, Part II & (Equivalent to NES 779, Part III). Seamless, Standard Length 6 Mtrs, +/-1 Mtrs Tolerance. All other dimensional tolerances shall be as per BS 2871, Part II.</p> <p>To be supplied with</p> <p>(i) MTC (Material, Dimensional & Testing).</p> <p>(ii) Bearing heat marks on each length at one end with tracability to MTC. Both ends to be suitably blanked.</p> <p>(iii) Pipes to be supplied without any coating.</p> <p>(iv) Pipes should be suitable for hot bending, cold bending, machine bending & collar formation. If any defects arise during fabrication, the pipe length to be replaced free of cost.</p>	2935
56	<p>Pipe, 90/10 Cu Ni, 200 NB, 219.1 OD, PN 10, 3 mm thk., As per CN 102 grade as per BS 2871, Part II & (Equivalent to NES 779, Part III). Seamless, Standard Length 6 Mtrs, +/-1 Mtrs Tolerance. All other dimensional tolerances shall be as per BS 2871, Part II.</p> <p>To be supplied with</p> <p>(i) MTC (Material, Dimensional & Testing).</p> <p>(ii) Bearing heat marks on each length at one end with tracability to MTC. Both ends to be suitably blanked.</p> <p>(iii) Pipes to be supplied without any coating.</p> <p>(iv) Pipes should be suitable for hot bending, cold bending, machine bending & collar formation. If any defects arise during fabrication, the pipe length to be replaced free of cost.</p>	730
57	<p>Pipe, 90/10 Cu Ni, 250 NB, 267 OD, PN 10, 3 mm thk., As per CN 102 grade as per BS 2871, Part II & (Equivalent to NES 779, Part III). Seamless, Standard Length 6 Mtrs, +/-1 Mtrs Tolerance. All other dimensional tolerances shall be as per BS 2871, Part II.</p> <p>To be supplied with</p> <p>(i) MTC (Material, Dimensional & Testing).</p> <p>(ii) Bearing heat marks on each length at one end with tracability to MTC. Both ends to be suitably blanked.</p> <p>(iii) Pipes to be supplied without any coating.</p> <p>(iv) Pipes should be suitable for hot bending, cold bending, machine bending & collar formation. If any defects arise during fabrication, the pipe length to be replaced free of cost.</p>	216
58	<p>Pipe, 90/10 Cu Ni, 300 NB, 323.9 OD, PN 10, 4 mm thk., As per CN 102 grade as per BS 2871, Part II & (Equivalent to NES 779, Part III). Seamless, Standard Length 6 Mtrs, +/-1 Mtrs Tolerance. All other dimensional tolerances shall be as per BS 2871, Part II.</p> <p>To be supplied with</p> <p>(i) MTC (Material, Dimensional & Testing).</p> <p>(ii) Bearing heat marks on each length at one end with tracability to MTC. Both ends to be suitably blanked.</p> <p>(iii) Pipes to be supplied without any coating.</p> <p>(iv) Pipes should be suitable for hot bending, cold bending, machine bending & collar formation. If any defects arise during fabrication, the pipe length to be replaced free of cost.</p>	216

Sr No	Description	Tentative Qty for 3 Yrs (Nos)
Mild Steel Flange		
59	<p>Flange, 15 NB, PN 10, Material - Mild Steel, IS 2062, E250 Br. & Dimensions as per BS EN 1092, Part 1, PN 10. Slip-on flange, Type 01 flange with Type A flat face with concentric serrations on one face.</p> <p>To be supplied with (i) MTC (Material, Dimensional & Testing). (ii) Permanent marking to be done on circumference by means of integral casting/forging or stamping (hard punch) as permanent identification. (iii) Material to be supplied non-galvanised. (iv) Material to be externally coated with primer.</p>	781
60	<p>Flange, 20 NB, PN 10, Material - Mild Steel, IS 2062, E250 Br. & Dimensions as per BS EN 1092, Part 1, PN 10. Slip-on flange, Type 01 flange with Type A flat face with concentric serrations on one face.</p> <p>To be supplied with (i) MTC (Material, Dimensional & Testing). (ii) Permanent marking to be done on circumference by means of integral casting/forging or stamping (hard punch) as permanent identification. (iii) Material to be supplied non-galvanised. (iv) Material to be externally coated with primer.</p>	647
61	<p>Flange, 25 NB, PN 10, Material - Mild Steel, IS 2062, E250 Br. & Dimensions as per BS EN 1092, Part 1, PN 10. Slip-on flange, Type 01 flange with Type A flat face with concentric serrations on one face.</p> <p>To be supplied with (i) MTC (Material, Dimensional & Testing). (ii) Permanent marking to be done on circumference by means of integral casting/forging or stamping (hard punch) as permanent identification. (iii) Material to be supplied non-galvanised. (iv) Material to be externally coated with primer.</p>	1701
62	<p>Flange, 32 NB, PN 10, Material - Mild Steel, IS 2062, E250 Br. & Dimensions as per BS EN 1092, Part 1, PN 10. Slip-on flange, Type 01 flange with Type A flat face with concentric serrations on one face.</p> <p>To be supplied with (i) MTC (Material, Dimensional & Testing). (ii) Permanent marking to be done on circumference by means of integral casting/forging or stamping (hard punch) as permanent identification. (iii) Material to be supplied non-galvanised. (iv) Material to be externally coated with primer.</p>	1075
63	<p>Flange, 40 NB, PN 10, Material - Mild Steel, IS 2062, E250 Br. & Dimensions as per BS EN 1092, Part 1, PN 10. Slip-on flange, Type 01 flange with Type A flat face with concentric serrations on one face.</p> <p>To be supplied with (i) MTC (Material, Dimensional & Testing). (ii) Permanent marking to be done on circumference by means of integral casting/forging or stamping (hard punch) as permanent identification. (iii) Material to be supplied non-galvanised. (iv) Material to be externally coated with primer.</p>	2066

Sr No	Description	Tentative Qty for 3 Yrs (Nos)
64	<p>Flange, 50 NB, PN 10, Material - Mild Steel, IS 2062, E250 Br. & Dimensions as per BS EN 1092, Part 1, PN 10. Slip-on flange, Type 01 flange with Type A flat face with concentric serrations on one face.</p> <p>To be supplied with (i) MTC (Material, Dimensional & Testing). (ii) Permanent marking to be done on circumference by means of integral casting/forging or stamping (hard punch) as permanent identification. (iii) Material to be supplied non-galvanised. (iv) Material to be externally coated with primer.</p>	3054
65	<p>Flange, 65 NB, PN 10, Material - Mild Steel, IS 2062, E250 Br. & Dimensions as per BS EN 1092, Part 1, PN 10. Slip-on flange, Type 01 flange with Type A flat face with concentric serrations on one face.</p> <p>To be supplied with (i) MTC (Material, Dimensional & Testing). (ii) Permanent marking to be done on circumference by means of integral casting/forging or stamping (hard punch) as permanent identification. (iii) Material to be supplied non-galvanised. (iv) Material to be externally coated with primer.</p>	3476
66	<p>Flange, 80 NB, PN 10, Material - Mild Steel, IS 2062, E250 Br. & Dimensions as per BS EN 1092, Part 1, PN 10. Slip-on flange, Type 01 flange with Type A flat face with concentric serrations on one face.</p> <p>To be supplied with (i) MTC (Material, Dimensional & Testing). (ii) Permanent marking to be done on circumference by means of integral casting/forging or stamping (hard punch) as permanent identification. (iii) Material to be supplied non-galvanised. (iv) Material to be externally coated with primer.</p>	2400
67	<p>Flange, 100 NB, PN 10, Material - Mild Steel, IS 2062, E250 Br. & Dimensions as per BS EN 1092, Part 1, PN 10. Slip-on flange, Type 01 flange with Type A flat face with concentric serrations on one face.</p> <p>To be supplied with (i) MTC (Material, Dimensional & Testing). (ii) Permanent marking to be done on circumference by means of integral casting/forging or stamping (hard punch) as permanent identification. (iii) Material to be supplied non-galvanised. (iv) Material to be externally coated with primer.</p>	1987
68	<p>Flange, 125 NB, PN 10, Material - Mild Steel, IS 2062, E250 Br. & Dimensions as per BS EN 1092, Part 1, PN 10. Slip-on flange, Type 01 flange with Type A flat face with concentric serrations on one face.</p> <p>To be supplied with (i) MTC (Material, Dimensional & Testing). (ii) Permanent marking to be done on circumference by means of integral casting/forging or stamping (hard punch) as permanent identification. (iii) Material to be supplied non-galvanised. (iv) Material to be externally coated with primer.</p>	1078

Sr No	Description	Tentative Qty for 3 Yrs (Nos)
69	<p>Flange, 150 NB, PN 10, Material - Mild Steel, IS 2062, E250 Br. & Dimensions as per BS EN 1092, Part 1, PN 10. Slip-on flange, Type 01 flange with Type A flat face with concentric serrations on one face.</p> <p>To be supplied with (i) MTC (Material, Dimensional & Testing). (ii) Permanent marking to be done on circumference by means of integral casting/forging or stamping (hard punch) as permanent identification. (iii) Material to be supplied non-galvanised. (iv) Material to be externally coated with primer.</p>	1154
70	<p>Flange, 200 NB, PN 10, Material - Mild Steel, IS 2062, E250 Br. & Dimensions as per BS EN 1092, Part 1, PN 10. Slip-on flange, Type 01 flange with Type A flat face with concentric serrations on one face.</p> <p>To be supplied with (i) MTC (Material, Dimensional & Testing). (ii) Permanent marking to be done on circumference by means of integral casting/forging or stamping (hard punch) as permanent identification. (iii) Material to be supplied non-galvanised. (iv) Material to be externally coated with primer.</p>	712
71	<p>Flange, 250 NB, PN 10, Material - Mild Steel, IS 2062, E250 Br. & Dimensions as per BS EN 1092, Part 1, PN 10. Slip-on flange, Type 01 flange with Type A flat face with concentric serrations on one face.</p> <p>To be supplied with (i) MTC (Material, Dimensional & Testing). (ii) Permanent marking to be done on circumference by means of integral casting/forging or stamping (hard punch) as permanent identification. (iii) Material to be supplied non-galvanised. (iv) Material to be externally coated with primer.</p>	280
72	<p>Flange, 300 NB, PN 10, Material - Mild Steel, IS 2062, E250 Br. & Dimensions as per BS EN 1092, Part 1, PN 10. Slip-on flange, Type 01 flange with Type A flat face with concentric serrations on one face.</p> <p>To be supplied with (i) MTC (Material, Dimensional & Testing). (ii) Permanent marking to be done on circumference by means of integral casting/forging or stamping (hard punch) as permanent identification. (iii) Material to be supplied non-galvanised. (iv) Material to be externally coated with primer.</p>	150
	Carbon Steel Flange	
73	<p>Flange, 15 NB, PN 10, Material - Carbon Steel, ASTM A 105 & Dimensions as per BS EN 1092, Part 3, PN 10. Carbon Steel Loose backing flange, Type 04 flange with Type A flat face .</p> <p>To be supplied with (i) MTC (Material, Dimensional & Testing). (ii) Permanent marking to be done on circumference by means of integral casting/forging or stamping (hard punch) as permanent identification. (iii) Material to be supplied galvanised as per BS 729.</p>	280

Sr No	Description	Tentative Qty for 3 Yrs (Nos)
74	<p>Flange, 20 NB, PN 10, Material - Carbon Steel, ASTM A 105 & Dimensions as per BS EN 1092, Part 3, PN 10. Carbon Steel Loose backing flange, Type 04 flange with Type A flat face .</p> <p>To be supplied with (i) MTC (Material, Dimensional & Testing). (ii) Permanent marking to be done on circumference by means of integral casting/forging or stamping (hard punch) as permanent identification. (iii) Material to be supplied galvanised as per BS 729.</p>	210
75	<p>Flange, 25 NB, PN 10, Material - Carbon Steel, ASTM A 105 & Dimensions as per BS EN 1092, Part 3, PN 10. Carbon Steel Loose backing flange, Type 04 flange with Type A flat face .</p> <p>To be supplied with (i) MTC (Material, Dimensional & Testing). (ii) Permanent marking to be done on circumference by means of integral casting/forging or stamping (hard punch) as permanent identification. (iii) Material to be supplied galvanised as per BS 729.</p>	450
76	<p>Flange, 32 NB, PN 10, Material - Carbon Steel, ASTM A 105 & Dimensions as per BS EN 1092, Part 3, PN 10. Carbon Steel Loose backing flange, Type 04 flange with Type A flat face .</p> <p>To be supplied with (i) MTC (Material, Dimensional & Testing). (ii) Permanent marking to be done on circumference by means of integral casting/forging or stamping (hard punch) as permanent identification. (iii) Material to be supplied galvanised as per BS 729.</p>	240
77	<p>Flange, 40 NB, PN 10, Material - Carbon Steel, ASTM A 105 & Dimensions as per BS EN 1092, Part 3, PN 10. Carbon Steel Loose backing flange, Type 04 flange with Type A flat face .</p> <p>To be supplied with (i) MTC (Material, Dimensional & Testing). (ii) Permanent marking to be done on circumference by means of integral casting/forging or stamping (hard punch) as permanent identification. (iii) Material to be supplied galvanised as per BS 729.</p>	740
78	<p>Flange, 50 NB, PN 10, Material - Carbon Steel, ASTM A 105 & Dimensions as per BS EN 1092, Part 3, PN 10. Carbon Steel Loose backing flange, Type 04 flange with Type A flat face .</p> <p>To be supplied with (i) MTC (Material, Dimensional & Testing). (ii) Permanent marking to be done on circumference by means of integral casting/forging or stamping (hard punch) as permanent identification. (iii) Material to be supplied galvanised as per BS 729.</p>	2005
79	<p>Flange, 65 NB, PN 10, Material - Carbon Steel, ASTM A 105 & Dimensions as per BS EN 1092, Part 3, PN 10. Carbon Steel Loose backing flange, Type 04 flange with Type A flat face .</p> <p>To be supplied with (i) MTC (Material, Dimensional & Testing).</p>	2420

Sr No	Description	Tentative Qty for 3 Yrs (Nos)
	(ii) Permanent marking to be done on circumference by means of integral casting/forging or stamping (hard punch) as permanent identification. (iii) Material to be supplied galvanised as per BS 729.	
80	Flange, 80 NB, PN 10, Material - Carbon Steel, ASTM A 105 & Dimensions as per BS EN 1092, Part 3, PN 10. Carbon Steel Loose backing flange, Type 04 flange with Type A flat face . To be supplied with (i) MTC (Material, Dimensional & Testing). (ii) Permanent marking to be done on circumference by means of integral casting/forging or stamping (hard punch) as permanent identification. (iii) Material to be supplied galvanised as per BS 729.	795
81	Flange, 100 NB, PN 10, Material - Carbon Steel, ASTM A 105 & Dimensions as per BS EN 1092, Part 3, PN 10. Carbon Steel Loose backing flange, Type 04 flange with Type A flat face . To be supplied with (i) MTC (Material, Dimensional & Testing). (ii) Permanent marking to be done on circumference by means of integral casting/forging or stamping (hard punch) as permanent identification. (iii) Material to be supplied galvanised as per BS 729.	645
82	Flange, 125 NB, PN 10, Material - Carbon Steel, ASTM A 105 & Dimensions as per BS EN 1092, Part 3, PN 10. Carbon Steel Loose backing flange, Type 04 flange with Type A flat face . To be supplied with (i) MTC (Material, Dimensional & Testing). (ii) Permanent marking to be done on circumference by means of integral casting/forging or stamping (hard punch) as permanent identification. (iii) Material to be supplied galvanised as per BS 729.	1360
83	Flange, 150 NB, PN 10, Material - Carbon Steel, ASTM A 105 & Dimensions as per BS EN 1092, Part 3, PN 10. Carbon Steel Loose backing flange, Type 04 flange with Type A flat face . To be supplied with (i) MTC (Material, Dimensional & Testing). (ii) Permanent marking to be done on circumference by means of integral casting/forging or stamping (hard punch) as permanent identification. (iii) Material to be supplied galvanised as per BS 729.	480
84	Flange, 200 NB, PN 10, Material - Carbon Steel, ASTM A 105 & Dimensions as per BS EN 1092, Part 3, PN 10. Carbon Steel Loose backing flange, Type 04 flange with Type A flat face . To be supplied with (i) MTC (Material, Dimensional & Testing). (ii) Permanent marking to be done on circumference by means of integral casting/forging or stamping (hard punch) as permanent identification. (iii) Material to be supplied galvanised as per BS 729.	355

Sr No	Description	Tentative Qty for 3 Yrs (Nos)
Gun Metal Flange		
85	<p>Flange, 15 NB, PN 10, Material - Gun metal, BS 1400 LG4C & Dimensions as per BS EN 1092, Part 3, PN 10. Gun metal Loose backing flange, Type 04 flange with Type A flat face .</p> <p>To be supplied with (i) MTC (Material, Dimensional & Testing). (ii) Permanent marking to be done on circumference by means of integral casting/forging or stamping (hard punch) as permanent identification.</p>	1070
86	<p>Flange, 20 NB, PN 10, Material - Gun metal, BS 1400 LG4C & Dimensions as per BS EN 1092, Part 3, PN 10. Gun metal Loose backing flange, Type 04 flange with Type A flat face .</p> <p>To be supplied with (i) MTC (Material, Dimensional & Testing). (ii) Permanent marking to be done on circumference by means of integral casting/forging or stamping (hard punch) as permanent identification.</p>	888
87	<p>Flange, 25 NB, PN 10, Material - Gun metal, BS 1400 LG4C & Dimensions as per BS EN 1092, Part 3, PN 10. Gun metal Loose backing flange, Type 04 flange with Type A flat face .</p> <p>To be supplied with (i) MTC (Material, Dimensional & Testing). (ii) Permanent marking to be done on circumference by means of integral casting/forging or stamping (hard punch) as permanent identification.</p>	2511
88	<p>Flange, 32 NB, PN 10, Material - Gun metal, BS 1400 LG4C & Dimensions as per BS EN 1092, Part 3, PN 10. Gun metal Loose backing flange, Type 04 flange with Type A flat face .</p> <p>To be supplied with (i) MTC (Material, Dimensional & Testing). (ii) Permanent marking to be done on circumference by means of integral casting/forging or stamping (hard punch) as permanent identification.</p>	1446
89	<p>Flange, 40 NB, PN 10, Material - Gun metal, BS 1400 LG4C & Dimensions as per BS EN 1092, Part 3, PN 10. Gun metal Loose backing flange, Type 04 flange with Type A flat face .</p> <p>To be supplied with (i) MTC (Material, Dimensional & Testing). (ii) Permanent marking to be done on circumference by means of integral casting/forging or stamping (hard punch) as permanent identification.</p>	2741
90	<p>Flange, 50 NB, PN 10, Material - Gun metal, BS 1400 LG4C & Dimensions as per BS EN 1092, Part 3, PN 10. Gun metal Loose backing flange, Type 04 flange with Type A flat face .</p> <p>To be supplied with (i) MTC (Material, Dimensional & Testing). (ii) Permanent marking to be done on circumference by means of integral casting/forging or stamping (hard punch) as permanent identification.</p>	2928

Sr No	Description	Tentative Qty for 3 Yrs (Nos)
91	<p>Flange, 65 NB, PN 10, Material - Gun metal, BS 1400 LG4C & Dimensions as per BS EN 1092, Part 3, PN 10. Gun metal Loose backing flange, Type 04 flange with Type A flat face .</p> <p>To be supplied with (i) MTC (Material, Dimensional & Testing). (ii) Permanent marking to be done on circumference by means of integral casting/forging or stamping (hard punch) as permanent identification.</p>	5544
92	<p>Flange, 80 NB, PN 10, Material - Gun metal, BS 1400 LG4C & Dimensions as per BS EN 1092, Part 3, PN 10. Gun metal Loose backing flange, Type 04 flange with Type A flat face .</p> <p>To be supplied with (i) MTC (Material, Dimensional & Testing). (ii) Permanent marking to be done on circumference by means of integral casting/forging or stamping (hard punch) as permanent identification.</p>	2430
93	<p>Flange, 100 NB, PN 10, Material - Gun metal, BS 1400 LG4C & Dimensions as per BS EN 1092, Part 3, PN 10. Gun metal Loose backing flange, Type 04 flange with Type A flat face .</p> <p>To be supplied with (i) MTC (Material, Dimensional & Testing). (ii) Permanent marking to be done on circumference by means of integral casting/forging or stamping (hard punch) as permanent identification.</p>	3675
94	<p>Flange, 125 NB, PN 10, Material - Gun metal, BS 1400 LG4C & Dimensions as per BS EN 1092, Part 3, PN 10. Gun metal Loose backing flange, Type 04 flange with Type A flat face .</p> <p>To be supplied with (i) MTC (Material, Dimensional & Testing). (ii) Permanent marking to be done on circumference by means of integral casting/forging or stamping (hard punch) as permanent identification.</p>	1285
95	<p>Flange, 150 NB, PN 10, Material - Gun metal, BS 1400 LG4C & Dimensions as per BS EN 1092, Part 3, PN 10. Gun metal Loose backing flange, Type 04 flange with Type A flat face .</p> <p>To be supplied with (i) MTC (Material, Dimensional & Testing). (ii) Permanent marking to be done on circumference by means of integral casting/forging or stamping (hard punch) as permanent identification.</p>	2465
96	<p>Flange, 200 NB, PN 10, Material - Gun metal, BS 1400 LG4C & Dimensions as per BS EN 1092, Part 3, PN 10. Gun metal Loose backing flange, Type 04 flange with Type A flat face .</p> <p>To be supplied with (i) MTC (Material, Dimensional & Testing). (ii) Permanent marking to be done on circumference by means of integral casting/forging or stamping (hard punch) as permanent identification.</p>	1100

Sr No	Description	Tentative Qty for 3 Yrs (Nos)
Bulkhead Fittings		
97	Galvanised Deck / bulkhead piece for Carbon Steel Pipes, Size: 15 NB, As per drawing DPSU-STD-DBH-STA-CST-PN010	12
98	Galvanised Deck / bulkhead piece for Carbon Steel Pipes, Size: 20 NB, As per drawing DPSU-STD-DBH-STA-CST-PN010	12
99	Galvanised Deck / bulkhead piece for Carbon Steel Pipes, Size: 25 NB, As per drawing DPSU-STD-DBH-STA-CST-PN010	72
100	Galvanised Deck / bulkhead piece for Carbon Steel Pipes, Size: 32 NB, As per drawing DPSU-STD-DBH-STA-CST-PN010	112
101	Galvanised Deck / bulkhead piece for Carbon Steel Pipes, Size: 40 NB, As per drawing DPSU-STD-DBH-STA-CST-PN010	285
102	Galvanised Deck / bulkhead piece for Carbon Steel Pipes, Size: 50 NB, As per drawing DPSU-STD-DBH-STA-CST-PN010	365
103	Galvanised Deck / bulkhead piece for Carbon Steel Pipes, Size: 65 NB, As per drawing DPSU-STD-DBH-STA-CST-PN010	277
104	Galvanised Deck / bulkhead piece for Carbon Steel Pipes, Size: 80 NB, As per drawing DPSU-STD-DBH-STA-CST-PN010	390
105	Galvanised Deck / bulkhead piece for Carbon Steel Pipes, Size: 100 NB, As per drawing DPSU-STD-DBH-STA-CST-PN010	285
106	Galvanised Deck / bulkhead piece for Carbon Steel Pipes, Size: 125 NB, As per drawing DPSU-STD-DBH-STA-CST-PN010	268
107	Galvanised Deck / bulkhead piece for Carbon Steel Pipes, Size: 150 NB, As per drawing DPSU-STD-DBH-STA-CST-PN010	234
108	Galvanised Deck / bulkhead piece for Carbon Steel Pipes, Size: 200 NB, As per drawing DPSU-STD-DBH-STA-CST-PN010	237
109	Galvanised Deck / bulkhead piece for Carbon Steel Pipes, Size: 250 NB, As per drawing DPSU-STD-DBH-STA-CST-PN010	46
110	Galvanised Deck / bulkhead piece for Carbon Steel Pipes, Size: 300 NB, As per drawing DPSU-STD-DBH-STA-CST-PN010	20
111	Non-Galvanised Deck / bulkhead piece for Carbon Steel Pipes, Size: 15 NB, As per drawing DPSU-STD-DBH-STA-CST-PN010	28
112	Non-Galvanised Deck / bulkhead piece for Carbon Steel Pipes, Size: 20 NB, As per drawing DPSU-STD-DBH-STA-CST-PN010	32
113	Non-Galvanised Deck / bulkhead piece for Carbon Steel Pipes, Size: 25 NB, As per drawing DPSU-STD-DBH-STA-CST-PN010	48
114	Non-Galvanised Deck / bulkhead piece for Carbon Steel Pipes, Size: 32 NB, As per drawing DPSU-STD-DBH-STA-CST-PN010	58
115	Non-Galvanised Deck / bulkhead piece for Carbon Steel Pipes, Size: 40 NB, As per drawing DPSU-STD-DBH-STA-CST-PN010	87
116	Non-Galvanised Deck / bulkhead piece for Carbon Steel Pipes, Size: 50 NB, As per drawing DPSU-STD-DBH-STA-CST-PN010	169
117	Non-Galvanised Deck / bulkhead piece for Carbon Steel Pipes, Size: 65 NB, As per drawing DPSU-STD-DBH-STA-CST-PN010	90
118	Non-Galvanised Deck / bulkhead piece for Carbon Steel Pipes, Size: 80 NB, As per drawing DPSU-STD-DBH-STA-CST-PN010	203
119	Non-Galvanised Deck / bulkhead piece for Carbon Steel Pipes, Size: 100 NB, As per drawing DPSU-STD-DBH-STA-CST-PN010	54
120	Non-Galvanised Deck / bulkhead piece for Carbon Steel Pipes, Size: 125 NB, As per drawing DPSU-STD-DBH-STA-CST-PN010	76
121	Non-Galvanised Deck / bulkhead piece for Carbon Steel Pipes, Size: 150 NB, As per drawing DPSU-STD-DBH-STA-CST-PN010	62

Sr No	Description	Tentative Qty for 3 Yrs (Nos)
122	Non-Galvanised Deck / bulkhead piece for Carbon Steel Pipes, Size: 200 NB, As per drawing DPSU-STD-DBH-STA-CST-PN010	71
123	Non-Galvanised Deck / bulkhead piece for Carbon Steel Pipes, Size: 250 NB, As per drawing DPSU-STD-DBH-STA-CST-PN010	26
124	Bush type Deck / bulkhead piece for 90/10 Cu Ni Pipe & Copper Pipes, Size: 15 NB, As per drawing DPSU-STD-DBH-BUS-CNI-PN010	92
125	Bush type Deck / bulkhead piece for 90/10 Cu Ni Pipe & Copper Pipes, Size: 25 NB, As per drawing DPSU-STD-DBH-BUS-CNI-PN010	158
126	Bush type Deck / bulkhead piece for 90/10 Cu Ni Pipe & Copper Pipes, Size: 32 NB, As per drawing DPSU-STD-DBH-BUS-CNI-PN010	34
127	Bush type Deck / bulkhead piece for 90/10 Cu Ni Pipe & Copper Pipes, Size: 40 NB, As per drawing DPSU-STD-DBH-BUS-CNI-PN010	123
128	Bush type Deck / bulkhead piece for 90/10 Cu Ni Pipe & Copper Pipes, Size: 50 NB, As per drawing DPSU-STD-DBH-BUS-CNI-PN010	224
129	Bush type Deck / bulkhead piece for 90/10 Cu Ni Pipe & Copper Pipes, Size: 65 NB, As per drawing DPSU-STD-DBH-BUS-CNI-PN010	261
130	Bush type Deck / bulkhead piece for 90/10 Cu Ni Pipe & Copper Pipes, Size: 80 NB, As per drawing DPSU-STD-DBH-BUS-CNI-PN010	159
131	Bush type Deck / bulkhead piece for 90/10 Cu Ni Pipe & Copper Pipes, Size: 100 NB, As per drawing DPSU-STD-DBH-BUS-CNI-PN010	134
132	Bush type Deck / bulkhead piece for 90/10 Cu Ni Pipe & Copper Pipes, Size: 125 NB, As per drawing DPSU-STD-DBH-BUS-CNI-PN010	185
133	Bush type Deck / bulkhead piece for 90/10 Cu Ni Pipe & Copper Pipes, Size: 150 NB, As per drawing DPSU-STD-DBH-BUS-CNI-PN010	80
134	Centre pad type Deck / bulkhead piece for 90/10 Cu Ni Pipes , Size: 15 NB, As per drawing DPSU-STD-DBH-PAD-CNI-PN010, Rev 1, dt. 24.03.2026	154
135	Centre pad type Deck / bulkhead piece for 90/10 Cu Ni Pipes , Size: 20 NB, As per drawing DPSU-STD-DBH-PAD-CNI-PN010, Rev 1, dt. 24.03.2026	126
136	Centre pad type Deck / bulkhead piece for 90/10 Cu Ni Pipes , Size: 25 NB, As per drawing DPSU-STD-DBH-PAD-CNI-PN010, Rev 1, dt. 24.03.2026	280
137	Centre pad type Deck / bulkhead piece for 90/10 Cu Ni Pipes , Size: 32 NB, As per drawing DPSU-STD-DBH-PAD-CNI-PN010, Rev 1, dt. 24.03.2026	195
138	Centre pad type Deck / bulkhead piece for 90/10 Cu Ni Pipes , Size: 40 NB, As per drawing DPSU-STD-DBH-PAD-CNI-PN010, Rev 1, dt. 24.03.2026	184
139	Centre pad type Deck / bulkhead piece for 90/10 Cu Ni Pipes , Size: 50 NB, As per drawing DPSU-STD-DBH-PAD-CNI-PN010, Rev 1, dt. 24.03.2026	270
140	Centre pad type Deck / bulkhead piece for 90/10 Cu Ni Pipes , Size: 65 NB, As per drawing DPSU-STD-DBH-PAD-CNI-PN010, Rev 1, dt. 24.03.2026	310
141	Centre pad type Deck / bulkhead piece for 90/10 Cu Ni Pipes , Size: 80 NB, As per drawing DPSU-STD-DBH-PAD-CNI-PN010, Rev 1, dt. 24.03.2026	315
142	Centre pad type Deck / bulkhead piece for 90/10 Cu Ni Pipes , Size: 100 NB, As per drawing DPSU-STD-DBH-PAD-CNI-PN010, Rev 1, dt. 24.03.2026	284
143	Centre pad type Deck / bulkhead piece for 90/10 Cu Ni Pipes , Size: 125 NB, As per drawing DPSU-STD-DBH-PAD-CNI-PN010, Rev 1, dt. 24.03.2026	170
144	Centre pad type Deck / bulkhead piece for 90/10 Cu Ni Pipes , Size: 150 NB, As per drawing DPSU-STD-DBH-PAD-CNI-PN010, Rev 1, dt. 24.03.2026	177
145	Centre pad type Deck / bulkhead piece for 90/10 Cu Ni Pipes , Size: 200 NB, As per drawing DPSU-STD-DBH-PAD-CNI-PN010, Rev 1, dt. 24.03.2026	61
146	Centre pad type Deck / bulkhead piece for 90/10 Cu Ni Pipes , Size: 250 NB, As per drawing DPSU-STD-DBH-PAD-CNI-PN010, Rev 1, dt. 24.03.2026	32

Sr No	Description	Tentative Qty for 3 Yrs (Nos)
147	Galvanised Deck / bulkhead piece for 90/10 Cu Ni Pipes , Size: 300 NB, As per drawing DPSU-STD-DBH-PAD-CNI-PN010, Rev 1, dt. 24.03.2026	15

APPLICATION FOR EMPANELMENT

(On the letter head of the Firm)

Dear Sir,

1. This has reference to your EOI document no. _____ for "Empanelment for Supply of Pipes, Flanges and Deck Bulkhead Fittings to Defence Public Sector Shipyards".
2. M/s. (Name of the Firm) hereby convey our consent for considering the expression of interest (EOI) along with information/documents submitted.
3. We confirm that M/s. (Name of the Firm) meets the qualification criteria mentioned in the subject EOI document.
4. We further state that;
 - (i) All information provided in the proposal and in the appendices is true and correct.
 - (ii) We shall make available to Defence Public Sector Shipyards any additional information necessary or required to supplement or authenticate the proposal
 - (iii) We are not under a declaration of ineligibility issued by Govt. of India /State govt./ UT /Public Sector Undertakings.
 - (iv) We do not have any conflict of interest in accordance with the Request for EOI document.
 - (v) We agree and undertake to abide by all the terms and conditions of the Request for EOI Document.
 - (vi) We are not under the purview of tender holidays / adverse ratings by any Government organization or large corporates on the date of EoI closing.
5. We hereby apply for empanelment as a contractor for following type of work and category.

Sr. No.	Scope of Supply Description	Product Category / Group for which response submitted
I	Carbon Steel Pipes	
II	Copper Pipes	
III	Cu-Ni Pipes	
IV	CS Flanges	
V	Mild Steel Flanges	
VI	Gun Metal Flanges	
VII	Deck Bulkhead Fittings	

Signature:

Name & Designation:

Company seal:

Date:

LIST OF SUPPLY SUCCESSFULLY COMPLETED DURING THE LAST THREE YEARS

1) Name of Applicant: _____

2) Description of Category of Supply for which response submitted for (Refer EOI clause No. 3.1):

3) Details of Qualification towards previous experience criteria for qualification under clause no. 4:

Sl. No.	PO No. & Date	Description of work	Name & Address of the Client	Date of start of work	Date of completion of work	Value of work executed excluding taxes as per Clause no.4	Work Completion Certificate no.& Date

Notes:

- 1. Specific information is to be filled up in each column w.r.t. pre-qualification documents as per the respective column headings. The PO and WDC/other supporting documents listed in this Annexure 3 will only be considered for qualification against this EOI.**
- The firm should submit copies of POs and WDC / WCC and other supporting documents specified in the above format to meet the pre-qualification criteria pertaining to the category in which the Firm has applied for empanelment.
- Please indicate only those supplies executed during last three (3) years (as stated in PQC) which fulfils the eligibility criteria of the applied scope of supply & category. Manufacture and Supply should have been executed by the firm under the name for which the current application is submitted.
- The above stated list is to be substantiated with the documentary evidence as per Clause no.4

Signature:

Name & Designation:

Company seal:

Date:

COMPANY PROFILE

1	Name of the Firm/Company		
2	Nature of the Business-Whether Manufacturer/Service Sub-Contractor/Authorized Agent/Trader.		
3	(a) Items of Manufacture / Agency / Service for which registration sought (b) Attached details of the products / services/ Technical Leaflets		
4	(a) Factory Address/ Phone No./ Fax No		
	(b) Registered Office Address/ Phone No./FAX No/ E-Mail/ Website		
	(c) Sales Office/Correspondence Address/Phone. No./ FAX No.		
5	Whether Public Limited/Private Limited/Partnership Firm/ Proprietary Firm/PSU		
6	Name of the Directors/Partners/ Proprietor.		
7	Is your Firm ISO accredited? If so attach Photo Copy of the valid Certificate.		
8	Whether your Firm is Registered, (a) Under Small Scale Industries / NSIC. – Furnish copy of valid certificate of MSME/NSIC (b) Under Partnership Act, 1932 –Furnish Photocopy of Partnership Deed and Registration Certificate issued by Registrar of Companies. (c) Under Indian Companies Act, 1956.- Furnish Copy of Certificate of Incorporation issued by Registrar of Companies. (d) With any other Govt. Undertaking/Defence PSUs/DGQA/Indian Navy/Indian Coast Guards – Submit Copy of Valid Certificates issued by such organization.		
9	(a) Factory License/Municipal Shop's and Establishment Certificate – Furnish Copy of Valid Certificate. (b) Registration Certificate from Labour Commissioner (In case of Labour Jobs.)		
10	GST Registration No. with photocopy of valid registration certificate.		
11	Copy of PAN Card and Copies of I.T. Return Paid Acknowledgements for the preceding 3 Assessment years.		

12	Name of the Bankers with address, Telephone number and FAX No., NEFT/RTGS/IFCS & MICR details to be furnished. Type of Account whether SB/Current/Cash Credit/Overdraft to be indicated.		
13	Names and address of your Associated/ Sister Manufacturing / Sub Contracting/Trading concerns and list of their directors/partners/proprietor of Company to be furnished.		
14	Date of commencement of Business.		
15	(a) List of Plant & Machineries owned (For manufacturers only). (b) Godown / Warehouse Area address with Phone Number together with latest Rent Receipt and valuation of stock. (for Stockiest and Service Sub- Contractors as applicable)		
16	Transport Facilities for Delivery and collection of Goods to and from our yards. (Applicable only for Service Sub-Contractor.)		
17	Names and designation of officials who will deal and interact with Defence Public Sector Shipyards officials for execution of the jobs.		
18	Are you in a position to supply the items duly approved by DGQA / Lloyds / ABS / IRS / DNV / other Third Party Agencies.		
20	Have you ever been Banned / Black Listed by any Govt. Undertaking(s)? If so, give details.		

DECLARATION BY THE APPLICANT FIRM/COMPANY

1. I/We hereby declare that the information pertaining to my / our Firm/Company including all enclosures is correct and true to the best of my/our knowledge and belief as on date.
2. I/We further confirm that Proprietor/Partners/Directors individually or jointly are not associated with any Firm / Company with which the dealings have been banned by the State/Central Govt. Departments/Public Sector Undertakings (Central / State).
3. I/We undertake not to employ directly or indirectly Defence Public Sector Shipyards Personnel / any Govt. Servants dismissed from Service in my / our business.
4. I/We notes that registration, as Defence Public Sector Shipyards Contractor does not carry with it, the right to business from Defence Public Sector Shipyards Works.
5. I/We certify that I /we will not get myself/ ourselves enlisted as contractor/s in the Undertaking (Defence Public Sector Shipyards) under more than one name.

AUTHORISED SIGNATORY _____

NAME (IN CAPITAL LETTER) _____

DESIGNATION _____

S E A L OF THE COMPANY.

PLACE _____

DATE: _____

NOTES:

1. If the space provided is insufficient, additional sheets may be attached as enclosures.
2. Complete / definite answers are required to be furnished against all clauses. In case particular clause is not applicable same should be clearly indicated against such clause indicating reasons, why clause is not applicable.
3. In the event it transpired later that false declaration / invalid documents were furnished at the time of applying against EoI, the response of the Firm/Company is liable for cancellation without any notice.

TERMS RELATED TO TAXES (GST)

1. GST as per GST Laws shall be payable extra as quoted and agreed.
2. In case of purchases of goods/services from unregistered dealers under GST Laws, GST will be paid by Defence Public Sector Shipyards under reverse charge mechanism.
3. Benefits from reduction in rate of tax/ITC are required to be passed on to consumer. Where “applicable GST” has been quoted as extra, Goods and service providers (except un-registered dealers under GST Law) have to submit declaration that they have complied with ‘Anti-profiteering clause’ under GST Law. Such declaration be given in technical bid.
4. If the vendor is registered under GST, vendor shall mention the HSN code for goods &/or services in their tax invoice, etc. These codes must be in accordance with GST Laws and responsibility of specifying correct HSN codes for goods &/or services is that of the vendor. Defence Public Sector Shipyards shall not be responsible for any error in HSN code for goods &/or services specified by supplier / contractor. Supplier /Contractor shall pay penalty and/ or interest imposed on Defence Public Sector Shipyards or any loss due to delay in availing ITC by Defence Public Sector Shipyards or any loss of ITC to Defence Public Sector Shipyards due to errors by vendors at any stage. Defence Public Sector Shipyards reserves right to recover any such interest, penalty or loss from any amount due to Supplier /Contractor or otherwise.
5. In case, Defence Public Sector Shipyards is unable to avail ITC, supplier/contractor at their own cost shall rectify the shortcoming in the returns to be filed immediately thereafter. Further, if the ITC is delayed / denied to Defence Public Sector Shipyards / reversed subsequently as per GST Laws due to non / delayed receipt of goods and / or services and / or tax invoice or expiry of timelines prescribed in GST Laws for availing ITC, non-payment of taxes or non-filing of returns or any other reason not attributable to Defence Public Sector Shipyards, Supplier /Contractor shall pay any loss of amount along with interest and penalty on Defence Public Sector Shipyards under GST Laws for the number of days the ITC was delayed. If the short coming is not rectified by supplier/contractor and Defence Public Sector Shipyards ends up in reversal of credits and / or payments, supplier /contractor is fully liable for making good all the loss incurred by Defence Public Sector Shipyards. Defence Public Sector Shipyards reserves right to recover any interest, penalty or loss from any amount due to Supplier /Contractor or otherwise.
6. If the vendor is registered under GST, the GST registration number (15 digit GSTIN) issued by GOI shall be mandatorily provided by the vendor. Vendor having multiple business verticals within state / at multiple states with separate GST registration numbers shall forward GSTIN of only that vertical which is involved in supply of goods and/or services. Defence Public Sector Shipyards GSTIN is 27AAACM8029J1ZA and vendor shall mention the same while invoicing and avoid any data entry error on GST portal.
7. If the vendor is registered under GST, Vendor shall ensure timely submission of invoice as per the provisions / requirement / timeline promulgated by GOI in relation to GST Law with all required supporting documents to enable Defence Public Sector Shipyards to avail input tax credit promptly. The vendors invoice inter alia should contain GSTIN of vendor, GSTIN of MDL (i.e. 27AAACM8029J1ZA) or GSTIN of Defence Shipyard placing the progressive Contract (ie GRSE GSTIN 19AAACG9371K1Z4/ HSL GSTIN 37AAACH4275P1Z2 / GSL GSTIN 30AAACG7569F1ZR), GST tax rate separately, HSN code wise goods or services, place of supply, signature of vendor, etc. Original invoice needs to be submitted to Bill Receipt Centre at MDL gate or as applicable at the Confirmatory Order placing Defence Public

Sector Shipyard. Invoice Copies should be given to the goods receiving section (GRS) at MDL or as applicable at the Confirmatory Order placing Defence Public Sector Shipyard.

8. If the vendor is registered under GST, vendor shall file all applicable returns under GST Laws in the stipulated time & any losses of tax credit to Defence Public Sector Shipyards arising due to delay in filing will be recovered from their invoice wherever Defence Public Sector Shipyards is eligible to avail tax credit. Any default towards payment of tax and / or uploading of monthly returns by supplier/contractor, Defence Public Sector Shipyards retains right to withhold payments towards tax portion until the same is corrected & complied by the supplier/contractor with the requirement of GST along with satisfactory evidence.
9. The rate sheet enclosed with the tender will indicate the rates to be entered under each head wherever applicable. Bidders must clearly mention the applicable Taxes & Duties. The item-wise rates (i.e. Basic+P&F+F&I) quoted in the Rate Sheet should exclude Taxes & Duties. Bidder should indicate GST rates as applicable separately under each of the head in the same Rate sheet, which will be paid extra based on tax invoice to the extent applicable. The GST will be applicable on total basic rate of each item (i.e. Basic + P&F + F&I).

GENERAL CONDITIONS OF CONTRACT (GCC) FOR GOODS AND SERVICES

The word 'Purchaser' refers to MAZAGON DOCK SHIPBUILDERS LIMITED, (MDL) / GRSE / HSL / GSL, a Company within the meaning of Companies Act, 2013 and it includes its successors or assignees.

The word 'Bidder' (including the term 'tenderer', 'consultant' 'vendor' or 'service provider' in certain contexts) means any legal entity such as firm(s) of Proprietorship / Partnership Firm / Limited Liability Partnership / Private Limited / Limited company / Society registered under Society's Act / Statutory Bodies/ Consortium/ Joint Venture etc. participating in a procurement process.

The word 'Owner' means the person or authority with whom Mazagon Dock Shipbuilders Limited (Purchaser) has contracted to carry out work in relation to which orders are placed by the Purchaser on the Bidder/Supplier/Contractor under this contract for supply or manufacture of certain items and would include Department of Defence Production, Ministry of Defence, Government of India, the Indian Navy, the Coast Guard and any other specified authority.

Unless otherwise indicated specifically by the bidder / contractor in his bid, it shall be construed as his acceptance of all the conditions mentioned in this GCC.

1. TENETS OF INTERPRETATION (Applicable for Goods and Services)

Unless where the context requires otherwise, throughout the contract:

- (a) The heading of these conditions shall not affect the interpretation or construction thereof.
- (b) Writing or written includes matter either whole or in part, in digital communications, manuscript, typewritten, lithographed, cyclostyled, photographed, or printed under or over signature or seal or digitally acceptable authentication, as the case may be.
- (c) Words in the singular include the plural and vice-versa.
- (d) Words importing the masculine gender shall be taken to include other genders, and words importing persons shall include any company or association or body of individuals, whether incorporated or not.
- (e) Terms and expression not herein defined shall have the meanings assigned to them in the Contract Act, 1872 (as amended) or the Sale of Goods Act, 1930 (as amended) or the General Clauses Act, 1897 (as amended) or of INCOTERMS, (current edition published by the International Chamber of Commerce, Paris) as the case may be.
- (f) Any reference to 'Goods' shall be deemed to include the incidental Works/ Services also.
- (g) Any generic reference to GCC shall also imply a reference to TEF as well.
- (h) In case of conflict, provisions of TEF shall prevail over those in GCC.
- (i) Any reference to 'Contract' shall be deemed to include all other documents (inter-alia GCC, TEF).
- (j) Any reference to any legal Act, Government Policies or orders shall be deemed to include all amendments to such instruments, from time to time, till date.
- (k) Fall Clause shall be expressly applicable in the case of Rate Contract.

2. LANGUAGE OF CONTRACT (Applicable for Goods and Services)

Unless otherwise stipulated in TEF, the contract shall be written in the Official Language or English. All correspondence and other contract documents, which the parties exchange, shall also be written/ translated accordingly in that language. For purposes of interpretation of the contract, the English documents/ translation shall prevail.

3. GOVERNING LAWS AND JURISDICTION (Applicable for Goods and Services)

3.1 Governing Laws and Jurisdiction

- (i) This Contract, its meaning and interpretation, and the relation between the Parties shall be governed by the Laws of India for the time being in force.
- (ii) Irrespective of the place of delivery, or the place of performance or the place of payments under the contract, the contract shall be deemed to have been made at the place from which the Purchase Order/Contract/Letter of Intent has been issued. The courts of such a place shall alone have jurisdiction to decide any dispute arising out or in respect of the contract.

3.2 Changes in Laws and Regulations

Unless otherwise stipulated in the contract, if after the last deadline for the bid submission (Techno-commercial), any law, regulation, ordinance, order or bye-law having the force of law is enacted, promulgated, abrogated, or changed in India (which shall be deemed to include any change in interpretation or application by the competent authorities) that subsequently affects the Delivery Date and/ or the contract Price, then such Delivery Date and/ or Contract Price shall be correspondingly increased or decreased, to the extent that the contractor has thereby been affected in the performance of any of its obligations under the contract. Notwithstanding the foregoing, such additional or reduced cost shall not be separately paid or credited if the same has already been accounted for in the price adjustment provisions where applicable.

4. **CONFIDENTIALITY, SECRECY AND IPR RIGHTS** (Applicable for Goods and Services)

(a) IPR Rights

All deliverables, outputs, plans, drawings, specifications, designs, reports, and other documents and software submitted by the contractor under this Contract shall become and remain the property of Defence Public Sector Shipyards and subject to laws of copyright and must not be shared with third parties or reproduced, whether in whole or part, without Defence Public Sector Shipyards's prior written consent. The contractor shall, not later than upon termination or expiration of this Contract, deliver all such documents and software to Defence Public Sector Shipyards, together with a detailed inventory thereof. The contractor may retain a copy of such documents and software but shall not use it for any commercial purpose.

(b) Confidentiality

All documents, drawings, samples, data, associated correspondence or other information furnished by or on behalf of Defence Public Sector Shipyards to the contractor, in connection with the contract, whether such information has been furnished before, during or following completion or termination of the contract, are confidential and shall remain the property of Defence Public Sector Shipyards and shall not, without the prior written consent of Defence Public Sector Shipyards neither be divulged by the contractor to any third party, nor be used by him for any purpose other than the design, procurement, or other services and work required for the performance of this Contract. If advised by Defence Public Sector Shipyards, all copies of all such information in original shall be returned on completion of the contractor's performance and obligations under this contract.

(c) Secrecy

If the Contract declares the subject matter of this Contract as coming under the Official Secrets Act, 1923 or if the contract is marked as "Secret", the contractor shall take all reasonable steps necessary to ensure that all persons employed in any connection with the contract, have acknowledged their responsibilities and penalties for violations under the Official Secrets Act and any regulations framed thereunder.

(d) Obligations of the contractor

- (i) Without Defence Public Sector Shipyards's prior written consent, the contractor shall not use the information mentioned above except for the sole purpose of performing this contract.
- (ii) The contractor shall treat and mark all information as confidential (or Secret – as the case may) and shall not, without the written consent of Defence Public Sector Shipyards, divulge to any person other than the person(s) employed by the contractor in the performance of the contract. Further, any such disclosure to any such employed person shall be made in confidence and only so far as necessary for such performance for this contract.
- (iii) Notwithstanding the above, the contractor may furnish to its holding company or its Subcontractor(s) such documents, data, and other information it receives from

Defence Public Sector Shipyards to the extent required for performing the contract. In this event, the contractor shall obtain from such holding company/ Subcontractor(s) an undertaking of confidentiality (or secrecy – as the case may be) similar to that imposed on the contractor under the above clauses.

- (iv) The obligation of the contractor under sub-clauses above, however, shall not apply to information that:
 - (aa) The contractor needs to share with the institution(s) participating in the financing of the contract;
 - (ab) now or hereafter is or enters the public domain through no fault of Contractor;
 - (ac) can be proven to have been possessed by the contractor at the time of disclosure and which was not previously obtained, directly or indirectly, from Defence Public Sector Shipyards; or
 - (ad) otherwise lawfully becomes available to the contractor from a third party that has no obligation of confidentiality.
- (v) The above provisions shall not in any way modify any undertaking of confidentiality (or Secrecy – as the case may be) given by the contractor before the date of the contract in respect of the contract/ the Tender Document or any part thereof.
- (vi) The provisions of this clause shall survive completion or termination for whatever reason of the contract.

5. PERMITS, APPROVALS AND LICENSES (Applicable for Goods and Services)

Whenever the supply of Goods and incidental Services requires that the contractor obtain permits, approvals, and licenses from local public authorities, it shall be the contractor's sole responsibility to obtain these and keep these current and valid. Such requirements may include but not be restricted to export licence or environmental clearance if required. If requested by the contractor, Defence Public Sector Shipyards shall make its best effort to assist the contractor in complying with such requirements in a timely and expeditious manner, without any dilution of the Contractor's responsibility in this regard.

6. TRANSFER OF TITLE OF GOODS (Applicable for Goods)

- (i) Unless otherwise stated in the contract, notwithstanding any inspection and approval by the Inspecting Officer on the contractor's premises, or any payments made to the contractor, property in the Goods (and resultant rights and liabilities) shall not pass on to Defence Public Sector Shipyards until the Goods have been received, inspected, and accepted by the consignee. The Goods and every constituent part thereof, whether in the possession or control of the contractor, his agents or servants or a carrier, or the joint possession of the contractor, his agents or servants and Defence Public Sector Shipyards, his agents, or servants, shall remain in every respect at the risk of the contractor, until their actual delivery to a person stipulated in the contract, as the interim consignee for dispatch to the consignee. The Contractor shall be responsible for all loss, destruction, damage, or deterioration of or to the Goods from any cause whatsoever while the Goods after approval by the Inspecting Officer are awaiting dispatch or delivery or are in the course of transit from the contractor to the consignee or interim consignee, as the case may be. The Contractor shall alone be entitled and responsible for making claims against any carrier in respect of non-delivery, short delivery, mis-delivery, loss, destruction, damage, or deterioration of the Goods entrusted to such carrier by the contractor for transmission to the consignee or the interim consignee as the case may be.
- (ii) Provided that where, under the terms of the contract, the Goods are required to be delivered to an interim consignee for despatch to the consignee, the Goods shall be at Defence Public Sector Shipyards's risk after their delivery to the interim consignee.

7. EXTENSION OF DELIVERY PERIOD (Applicable for Goods)

- (i) If at any time during the currency of the contract, the contractor encounters conditions hindering timely delivery of the Goods and performance of incidental Works/ Services, he shall promptly inform Defence Public Sector Shipyards in writing about the same and its likely duration. He must make a request to Defence Public Sector Shipyards for an

extension of the delivery schedule. On receiving the contractor's communication, Defence Public Sector Shipyards shall examine the situation and, at its discretion, may agree to extend the delivery schedule, with or without liquidated damages and with and without denial clause by issuing an amendment to the contract.

(ii) Conditions for Extension of Delivery Period

When the period of delivery is extended due to unexcused delay (Note: please ensure that unexcused delay is defined. Otherwise replace "unexcused delay" with the "delays attributable") by the contractor, the amendment extending the delivery period shall, inter alia, be subject to the following conditions:

a. Liquidated Damages

Defence Public Sector Shipyards shall recover from the contractor, under the provisions of this clause, liquidated damages on the Goods and incidental Works/ Services, which the contractor has failed to deliver within the delivery period stipulated in the contract.

b. Denial Clause

- (aa) No increases in price on account of any statutory increase in or fresh Imposition of GST, customs duty or on account of any other taxes/ duty/ cess/ levy), leviable in respect of the Goods and incidental Works/ Services stipulated in the said contract which takes place after the original delivery date, shall be admissible on such of the said Goods, as are delivered after the said date; and
- (ab) Notwithstanding any stipulation in the contract for an increase in price on any other ground, including price variation clause or foreign exchange rate variation, or any other variation clause, no such increase after the original delivery date shall be admissible on such goods delivered after the said date.
- (ac) Nevertheless, Defence Public Sector Shipyards shall be entitled to the benefit of any decrease in price on account of reduction in or remission of GST, customs duty or on account of any other Tax or duty or any other ground as stipulated in the price variation clause or foreign exchange rate variation or any other variation clause which takes place after the expiry of the original delivery date.

(iii) Liquidated damages

If the contractor fails to deliver any or all of the Goods or fails to perform the incidental Works/ Services (e.g. installation, commissioning or operator training) within the time frame(s) incorporated in the contract, Defence Public Sector Shipyards shall, without prejudice to other rights and remedies available to Defence Public Sector Shipyards under the contract, deduct from the contract price, as agreed liquidated damages, but not as a penalty, a sum equivalent to the 0.5 % percent (excluding taxes) of the delivered price of the delayed Goods and/ or incidental Works/ Services for each week of delay or part thereof until actual delivery or performance, subject to a maximum deduction of the 10% of the delayed Goods' or incidental Works/ Services' contract price(s). Besides liquidated damages during such a delay, the denial clause shall also apply. Any failure or delay by any sub-contractor, though their employment may have been sanctioned shall not be admitted as a ground for any extension of time or for exempting the contractor from liability for any such loss or damage as aforesaid.

8. DEFAULTS, BREACHES & TERMINATION OF CONTRACT (Applicable for Goods and Services)

Termination due to Breach, Default, and Insolvency

(a) Defaults and Breach of Contract

In case the contractor undergoes insolvency or receivership; neglects or defaults, or expresses inability or disinclination to honour his obligations relating to the performance of the contract or ethical standards or any other obligation that substantively affects Defence Public Sector Shipyards's rights and benefits under the contract, it shall be treated as a breach of Contract. Such defaults shall include inter-alia:

(i) Default in Performance and Obligations

If the contractor fails to deliver any or all of the Goods or fails to perform any other contractual obligations (including Code of Integrity or obligation to maintain eligibility and Qualifications based on which contract was awarded) within the period stipulated in the contract or within any extension thereof granted by Defence Public Sector Shipyards.

(ii) Insolvency

If the contractor is wound up or ceases to otherwise trade or is unable to pay its debts as and when they fall due or is otherwise subject to any insolvency procedure.

(iii) If a receiver or similar official is appointed overall or any of the assets of the contractor or a petition is presented for its winding up or it entered into a composition with its creditors;

(b) Notice for Default

As soon as a breach of contract is noticed, a show-cause 'Notice of Default' shall be issued to the contractor, giving two weeks' notice, reserving the right to invoke contractual remedies. After such a show-cause notice, all payments to the contractor would be temporarily withheld to safeguard needed recoveries that may become due on invoking contractual remedies.

(c) Terminations for Default

(i) Notice for Termination for Default: In the event of unsatisfactory resolution of 'Notice of Default' within two weeks of its issue as per sub-clause above, Defence Public Sector Shipyards if so decided, shall by written Notice of Termination for Default sent to the contractor, terminate the contract in whole or in part, without compensation to the contractor.

(ii) Such termination shall not prejudice or affect the rights and remedies, including under sub-clause below, which have accrued and/ or shall accrue to Defence Public Sector Shipyards after that.

(iii) Unless otherwise instructed by Defence Public Sector Shipyards, the contractor shall continue to perform the contract to the extent not terminated. All warranty obligations, if any, shall continue to survive despite the termination.

(d) Contractual Remedies for Breaches/Defaults or Termination for Default

If there is an unsatisfactory resolution within this period, Defence Public Sector Shipyards shall take one; or more of the following contractual remedies.

(i) Temporary withhold payments due to the contractor till recoveries due to invocation of other contractual remedies are complete.

(ii) Call back any loaned property or advances of payment, if any, with the levy of interest at the prevailing rate (MIBID - Mumbai Interbank Bid Rate).

(iii) Recover liquidated damages and invoke denial clause for delays.

(iv) Encash and/ or Forfeit performance or other contractual securities.

(v) Prefer claims against insurances, if any.

(vi) Terminate contract for default, fully or partially including its right for Risk-and-Cost Procurement as per following sub-clause.

(vii) Risk and Cost Procurement

In addition to termination for default, Defence Public Sector Shipyards shall be entitled, and it shall be lawful on his part, to procure Goods same to those terminated, with such terms and conditions and in such manner as it deems fit at the "Risk and Cost" of the contractor. Such 'Risk and Cost Procurement' must be initiated (viz. AIP/PR/Tender) within six months from the termination of Contract. The Contractor shall be liable for any loss which Defence Public Sector Shipyards may sustain on that account provided the procurement, or, if there is an agreement to procure, such agreement is made. The Contractor shall not be entitled to any gain on such

procurement, and the manner and method of such procurement shall be in the entire discretion of Defence Public Sector Shipyards.

Note: Regarding the Goods which are not readily available in the market and where procurement difficulties are experienced, the period for making risk procurement shall be nine months instead of six months provided above.

- (viii) Initiate legal proceedings in a for the recovery of the losses and damages, not addressable by the above means.

9. CLOSURE OF CONTRACT (Applicable for Goods and Services)

The contract shall stand closed upon successful performance of all obligations by the firm, including completion of warrantee obligations and final payment. If no claim is received within 03 years from last supplies/services, then no claim shall be entertained thereafter.

10. COMMUNICATION AND LANGUAGE FOR DOCUMENTATION (Applicable for Goods and Services)

Any letter, facsimile message, e-mail intimation or notice sent to the Bidder/Supplier/ Contractor at the last known address mentioned in the offer / order shall be deemed to be valid communication for the purpose of the order/contract. Unless stated otherwise by the purchaser, Language for communication and all documentation shall be same, which the Purchaser has used, in the tender enquiry.

11. PRESERVATION AND MAINTENANCE (Applicable for Goods)

Should any material require any preservation till its final installation/fitment, the detailed procedure (Long term and short term) for the same as also the time of interval after which the state of preservation needs to be reviewed is to be stated by the Bidder/Supplier/Contractor.

Further the de-preservation prior to the material/equipment being commissioned and the maintenance procedure together with its periodicity is also to be indicated by the Bidder / Supplier / Contractor.

12. FREIGHT AND INSURANCE. (Applicable for Goods)

(a) For Indigenous Bidders

Bidder shall quote for 'Door Delivery to Purchaser,' all charges towards door delivery viz. transport, Insurance charges etc. shall be borne by the Bidder / Supplier / Contractor.

(b) For Foreign Bidders

For overseas bidders, bidder shall agree for supplying the goods on CIF/CIP, Incoterm basis. The Bidder / Supplier / Contractor shall immediately on despatch of the items, inform all relevant details of despatch such as Order Number, Bill of Lading/AWB Number marked as Freight Paid, Insurance policy/document, number of packages, value of consignment, invoice number etc. as per contractual terms.

13. DEMURRAGE (Applicable for Goods)

Storage, and Demurrage, fines etc. charges will be payable by the Bidder / Supplier / Contractor for all shipments in case of improper documentation, wrong declarations, error in weight measurements, packing list, invoice, late receipt of documents etc. i.e. for reasons which are not attributable to the purchaser.

14. CANCELLATION OF TENDER (Applicable for Goods and Services)

The Purchaser reserves the right to cancel/withdraw the tender in toto or part and or award the contract / order in full or part without assigning any reason whatsoever and without thereby incurring any liability to the affected Bidder or Bidders or any obligations to inform the affected Bidder or Bidders of the grounds for Defence Public Sector Shipyards action.

15. PURCHASER'S PROPERTY(Applicable for Goods and Services)

All property (such as materials, drawings, documents etc.) issued by the Purchaser or any other individual or firm on behalf of the Purchaser in connection with the contract shall remain

confidential, being the property of the Purchaser and the Bidder/Supplier/Contractor shall undertake to return all such property so issued and will be responsible for any or all loss thereof and damage thereto resulting from whatever causes and shall reimburse the Purchaser the full amount of loss and damage.

On completion of work in any compartment / location of the purchaser's premises, the Bidder/Supplier/Contractor must ensure that the place is left in a reasonably clean state and all scrap is transferred to nearby scrap-bins.

16. REJECTION OF MATERIALS (Applicable for Goods)

If the Goods, or any portion thereof of the equipment found defective / rejected, the Supplier / Contractor shall collect the same from Defence Public Sector Shipyards's Stores, all incidental charges being borne by him (inclusive of Custom duty, if payable), within 30 days from the date of intimation to the Supplier / Contractor of such rejection. If not collected within 30 days, Defence Public Sector Shipyards shall recover storage charges @ 1 % per month maximum up to 5% of cost of rejected items. Defence Public Sector Shipyards reserves the right to dispose off the rejected items at the end of a total period of six months in any manner to the best advantage to Defence Public Sector Shipyards and recover consequential damages maximum up to order value.

17. RECOVERY-ADJUSTMENT PROVISIONS (Applicable for Goods and Services)

Payment made under one order shall not be assigned or adjusted to any other order except to the extent agreed upon in writing by the Purchaser. During the currency of the contract, if any sum of money is payable by the Bidder / Supplier / Contractor the same shall be deducted from any sum then due or thereafter may become due to the Bidder / Supplier / Contractor under the contract or any other contract with the Purchaser.

18. INDEMNIFICATION (Applicable for Goods and Services)

The Bidder / Supplier / Contractor, his employees, licences, agents or Sub-Supplier / Sub-contractor, while on site of the Purchaser for the purpose of this contract, indemnifies the Purchaser against direct damage and/or injury to the property and/or the person of the Purchaser or that of Purchaser's employees, agents, Sub-Contractors / Suppliers occurring and to the extent caused by the negligence of the Bidder / Supplier / Contractor, his employees, licensees, agents or Sub-contractor by making good such damages to the property, or compensating personal injury and the total liability for such damages or injury shall be as mutually discussed and agreed to.

19. TRANSFER OF SUPPLIERS / CONTRACTOR'S RIGHTS (Applicable for Goods and Services)

The Bidder / Supplier / Contractor shall not either wholly or partly sell, transfer, assign or otherwise dispose of the rights, liabilities and obligations under the contract between him and the Purchaser without prior consent of the Purchaser in writing.

20. SUBCONTRACT AND RIGHT OF PURCHASER (Applicable for Goods and Services)

The Bidder / Supplier / Contractor under no circumstances undertake or subcontract any work / contract from or to any other Sub-contractor without prior written approval of the Competent Authority of Purchaser. In the event it is found that such practice has been indulged in, the contract is liable to be terminated without notice and the Bidder / Supplier / Contractor is debarred all from future tender enquiries / work orders. However, in no circumstances a contractor is permitted to subcontract any part of the contract to the bidders who had quoted for the concerned tender.

21. PATENT RIGHTS (Applicable for Goods and Services)

The Bidder / Supplier / Contractor shall hold harmless and keep the Purchaser indemnified against all claims arising as a result of infringement of any patent / copy rights on account of manufacture, sale or use of articles covered by the order.

22. AGENTS/AGENCY COMMISSION (Applicable for Goods and Services)

The seller confirms and declares to the buyer that the seller is the original manufacturer or authorized distributor/stockiest of original manufacturer of the goods referred to in this contract and has not engaged any individual or firm, whether Indian or foreign whatsoever, to intercede, facilitate or in any way to recommended to the Buyer or any of its functionaries, whether officially or unofficially, to the award of the Contract / Purchase order to the Seller; nor has any amount been paid, promised or intended to be paid to any such individual or firm in respect of any such intercession, facilitation or recommendation.

The Seller agrees that if it is established at any time to the satisfaction of the Buyer that the present declaration is in any way incorrect or if at a later stage it is discovered by the Buyer that the Seller has engaged any such individual/firm, and paid or intended to pay any amount, gift, reward, fees, commission or consideration to such person, party, firm or institution, whether before or after the signing of this Contract / Purchase order, the Seller will be liable to refund that amount to the Buyer.

The seller will also be debarred from participation in any RFQ/Tender for new projects/program with Buyer for a minimum period of five years.

The buyer will also have a right to consider cancellation of the Contract either wholly or in part, without any entitlement or compensation to the Seller who shall in such event be liable to refund all payments made by the buyer in terms of the Contract along with interest at the rate of 2% per annum or 6% whichever is higher above LIBOR (London Inter Bank Offer Rate) (for foreign vendors) and base rate of SBI plus 2% (for Indian Vendors).

The Buyer will also have the right to recover any such amount from any contracts concluded earlier with Buyer.

23. USE OF UNDUE INFLUENCE / CORRUPT PRACTICES (Applicable for Goods and Services)

The Bidder / Supplier / Contractor undertakes that he has not used corrupt practices or used any undue influence which is not admissible as per Indian law to obtain contract/order or in doing any business with the purchaser.

If found that Bidder / Supplier / Contractor is involved in such wrong practices, then Purchaser is entitled to cancel the contract/s and all or any other contracts and then to recover from the Bidder / Supplier / Contractor the amounts of any loss arising from such contracts' cancellation, including but not limited to imposition of penal damages, forfeiture of Performance security, encashment of the Bank Guarantee and refund of the amounts paid by the Purchaser.

24. IMMUNITY OF GOVERNMENT OF INDIA CLAUSE (Applicable for Goods and Services)

It is expressly understood and agreed by and between M/s. (Bidder / Supplier / Contractor) and Mazagon Dock Shipbuilders Limited, Dockyard Road, Mumbai - 400 010 (MDL) / Defence Public Sector Shipyards is entering into this Agreement solely on its own behalf and not on the behalf of any person or entity. In particular, it is expressly understood and agreed that the Government of India is not a party to this Agreement and has no liabilities, obligations or rights hereunder. It is expressly understood and agreed that Defence Public Sector Shipyards is an independent legal entity with power and authority to enter into contracts solely in its own behalf under the applicable of Laws of India and general principles of Contract Law. The (Bidder / Supplier / Contractor) expressly agrees, acknowledges and understands that Defence Public Sector Shipyards is not an agent, representative or delegate of the Government of India. It is further understood and agreed that the Government of India is not and shall not be liable for any acts, omissions and commissions, breaches or other wrongs arising out of the contract. Accordingly, (Bidder / Supplier / Contractor) hereby expressly waives, releases and foregoes any and all actions or claims, including cross claims, impleader claims or counter claims against the Government of India arising out of this contract and covenants not to sue Government of India in any manner, claim, cause of action or thing whatsoever arising of or under this Agreement.

25. EXPORT LICENCE (Applicable for Goods and Services)

The export licenses that may be required for delivery of the various items/equipment to Defence Public Sector Shipyards shall be arranged by the Bidder / Supplier / Contractor from the concerned authorities in their country without any time and cost implications on the Purchaser.

26. BANNED OR DE-LISTED CONTRACTORS / SUPPLIERS (Applicable for Goods and Services)

The Bidder / Supplier / Contractor declares that they being Proprietors / Directors / Partners have not been any time individually or collectively blacklisted or banned or de-listed by any Government or quasi Government agencies or PSUs. If a bidder's entities as stated above have been blacklisted or banned or de-listed by any Government or quasi Government agencies or PSUs, this fact must be clearly stated and it may not necessarily be a cause for disqualifying him.

27. **DUTY OF PERSONNEL OF SUPPLIER/CONTRACTOR** (Applicable for Goods and Services)
Defence Public Sector Shipyards being a Defence Public Sector Undertaking, Bidder / Supplier / Contractor undertakes that their personnel deployed in connection with the entrusted work will not indulge in any activities other than the duties assigned to them.

28. **DISPUTE RESOLUTION MECHANISM AND ARBITRATION** (Applicable for Goods and Services)

(a) Dispute resolution mechanism(DRM)

(i) Any dispute/differences between the parties arising out of and in connection with the contract shall be settled amicably by mutual negotiations at HoS/HoD level.

(ii) In case of non-settlement by (i) above, if at any time, before, during or after the contract period any unsettled claim, dispute or difference arose between the parties, upon or in relation to or in connection with or in any way touching or concerning this tender/agreement/order/contract, the same shall be referred to the concerned Functional Director.

The Functional Director shall then nominate an Executive of the rank of General Manager whom he thinks fit and competent or a Committee of Executives who/which shall then scrutinise the claims/disputes that have been referred to the concerned functional Director and make efforts for amicable settlements by mutual discussions/negotiations.

(iii) In case no amicable settlement is arrived by (ii) above within a period of three months, then the contractor shall approach Public Grievance Cell and address the disputes as per the provisions made under the relevant clause of the contract.

(iv) In case the issues/disputes do not get settled within a period of six months from the date of submission of the dispute to the Grievance Cell, then the contractor may invoke Arbitration Clause of the contract.

(b) Arbitration (Applicable for Goods and Services)

Unresolved disputes/differences, if any, shall then be settled by Arbitration. The Arbitration proceedings shall be conducted at Mumbai, India, in English Language, under the Arbitration and Conciliation Act, 1996 as amended from time to time and the rules thereunder.

Defence Public Sector Shipyards prefers to have arbitration through Institutes such as Indian Council of Arbitration (ICA)/ICA-DR, Mumbai Centre for International Arbitration, International Chamber of Commerce (ICC), Singapore International Arbitration Centre (SIAC) with the mutual consent of the parties.

In case of unresolved difference/dispute between the Purchaser and Supplier, being Central Public Sector Enterprises/Central Govt. departments, the disputes shall be resolved firstly through mutual discussion or through the empowered agencies of the Govt. or through arbitration by reference by either party to the department of Public Enterprises, as per extant guidelines. If disputes/differences remain unresolved/unexecuted, the same shall be referred first to the Cabinet Secretariat and then, if necessary to the PMO.

Any changes to arbitration clause must be vetted by HOD (Legal) before incorporation in contract/PO.

29. **JURISDICTION OF COURTS** (Applicable for Goods and Services)

All contracts shall be deemed to have been wholly made in Mumbai / place of order placing Defence Public Sector Shipyard and all claims there under are payable in Mumbai City and it is the distinct condition of the order that no suit or action for the purpose of enforcing any claim in

respect of the order shall be instituted in any Court other than that situated in Mumbai City, Maharashtra State, India i.e. courts in Mumbai shall alone have jurisdiction to decide upon any dispute arising out of or in respect of the contract.

30. **SAFETY** (Applicable for Goods & Services)

The Contractor / Bidder must observe all safety precautions in connection with the work to be performed by him, his agents or labourers. In the event of any accident happening in our yard resulting in loss of lives or otherwise damaging any part of the property, the contractor shall be required to make good the loss to the Company and shall be responsible for all consequences that follow from the loss and / or injuries to the persons involved in such accidents. The standard of safety to be observed in the Company shall be decided by the Executive-in-Charge Safety, or any Executive appointed for the purpose before the commencement of work in the yard. It will be essential for contractor to ascertain the standard precautions which contractor is required to observe in discharging his work as per the standards prevalent in Defence Public Sector Shipyards. The decision of Defence Public Sector Shipyards in matters concerning Safety shall be final and binding on the contractor.

The Contractor / Bidder shall be required to provide his workmen with Boiler Suits of any suitable colour other than blue or white, with the Name of the Contractor in prominent letters on the boiler suits along with personal protection gears like safety shoes, hand gloves etc. workmen of the Contractor / Bidder must wear throughout their working while in the premises of Defence Public Sector Shipyards. Contractor's workmen working without safety gears are to be disallowed for work.

31. **POLICE VERIFICATION OF EMPLOYEES** (Applicable for Services)

Contractor / Bidder shall have to produce and submit to the Chief Security Executive of Purchaser, verification through Mumbai Police of Character and Antecedents of their employees / workers for while working on ships under construction in Purchaser's Yards, for working onboard ships under modernisation / refit / repairs at Mumbai ports / Naval Dockyard. Entry passes will not be issued in the absence of Police Verification Report and employees without Police Verification shall not be employed by them in Purchaser's Yard / Mumbai ports / Naval Dockyard and any lapse on the part of Contractor / Bidder shall be viewed seriously as per applicable laws of the land. Employment of any Foreign National during the contract period would be permitted with prior permission of Purchaser.

32. **FORCE MAJEURE** (Applicable for Goods and Services)

If at any time during the execution of the goods / service order, the performance in whole or in part by either Purchaser or and by the Bidder(s) / Supplier(s) / Contractor(s) is / are delayed by any reason of force majeure situations such as acts of civil war, civil commotion, sabotage, hostilities, war, fires, explosions, epidemics, natural calamities like floods, earthquakes, volcanoes, storms, acts of God and laws of respective governments or any other causes beyond the control of either parties, hereinafter referred to as "events", provided notice of the occurrence of such event/s is / are communicated by either party, to the other party within 21 days from the date of occurrence thereof, neither party shall by reason such events be entitled to terminate the contract nor shall either party have any claim for damages against the other in respect of such non-performance and or delay in performance of the contract / order. Executions on either side shall be resumed as soon as practicable after such event has come to an end or ceased to exist and the decision of Purchaser as to whether activities can resume or not, shall be conclusive and final. Occurrence of the events to be certified by Chamber of Commerce / Indian High Commission or Embassies / Government in that Country.

The performance in whole or in part under the captioned tender / contract is prevented or delayed by reason of any such event for a period exceeding sixty days either party may at its option terminate the contract / further processing of the tender. The relative obligations of both the parties remain suspended during the actual period of force majeure.

The Purchaser may extend the delivery schedule as mutually agreed, on receipt of written communication from the Bidder / Supplier / Contractor regarding occurrence of 'Force Majeure' conditions, but not exceeding six months from the scheduled delivery date. If the 'Force Majeure'

conditions extend beyond this period, the Purchaser shall have the right to cancel the order without any financial implication to the Purchaser or on terms mutually agreed to.

GENERAL CONDITIONS OF CONTRACT ACCEPTANCE FORMAT

To,
<EOI issuing Defence Shipyard>

GCC CLAUSE No.	BIDDER'S REMARK	GCC CLAUSE No.	BIDDER'S REMARK	GCC CLAUSE No.	BIDDER'S REMARK
	Acc/Dev		Acc/Dev		Acc/Dev
1		14		27	
2		15		28	
3		16		29	
4		17		30	
5		18		31	
6		19		32	
7		20			
8		21			
9		22			
10		23			
11		24			
12		25			
13		26			

COMPANY'S NAME & ADDRESS:

SIGNATURE:

DATE:

NAME:

DESIGNATION:

BIDDER'S COMPANY SEAL:

NOTE:

- Bidders should carefully read the GENERAL CONDITIONS OF CONTRACT of the Tender (GCC) prior to filling up this acceptance format (available on MDL Web site)
- This format should be properly filled, signed and bidder shall upload the scanned copy of the same online.
- Bidder(s) should indicate "ACC" for Accepted, "DEV" for Deviation Taken for each clause number in the above table. Bidder(s) to attach Separate Sheet indicating all relevant details such as Number & description of the Clause, Reasons for Deviation and Alternative suggested for any deviations taken by them.

EXTRACT OF PROVISIONS OF THE OFFICIAL SECRETS ACT, 1923*(ILLUSTRATIVE FORMAT)***SECTION 2(B) ; “PROHIBITED PLACE”**

It is defined as the place of any work of Defence Dockyard and other so belonging or occupied and used for the purpose of building, repairing, making or storing any ammunitions of war.

For the purpose of the above definition, sketch includes any photograph or other mode of representing any place or thing.

SECTION 3 : “PENALTIES FOR SPYING”

If any per unlawfully -

- a) approaches, inspects, passes over or is in the vicinity of any clear place; or
- b) make any sketches intended to be directly or indirectly useful to an enemy; or
- c) obtains, collects, records or communicates to any other person any secret official code.

Shall be liable for imprisonment of 14 years in case of Defence Installation.

SECTION 4 : “COMMUNICATION WITH FOREIGN AGENTS”

If Any person has been in communication with or attempted to communicate with foreign agents regarding the vital information of any “PROHIBITED PLACE” would be guilty of violating the provisions of this Act.

SECTION 5 : “WRONGFUL COMMUNICATION OF INFORMATION”

If any person having in his possession or control any official document;

- a) Willfully communicates to any person, other than a person, who is authorised to communicate it.
- b) Used the information in his possession for the benefit of any foreign power.
- c) Retain in his possession when he has no power to retain it
- d) Fails to take reasonable care of it.

Shall be guilty of an offence under this Act.

SECTION 6 : “UNAUTHORISED USE OF UNIFORMS”

If any person for the purpose of gaining admission or of assisting any other person to gain admission to a “PROHIBITED PLACE” wears uniforms without lawful authority shall be guilty of offence under this Section.

SECTION 7 : “INTERFERING WITH OFFICERS OF POLICE”

No person in the vicinity of any “PROHIBITED PLACE” shall abstract any Police Officer engaged on guard, sentry or similar duty. If any person move in the provisions of this section, shall be punishable with imprisonment, which may extend up to 3 years.

SECTION 8 : “DUTY OF GIVING INFORMATION”

It shall be duty of every person to give on demand to a superintendent of Police or any other Police Officer not below the rank of Inspector, any information in his power relating to an offence under this Act.

If any person fails to give such information, shall be punishable with imprisonment to 3 years or fine or with both.

SECTION 9 : “INCITEMENT”

Any person who attempts to commit or debate the commission of an offence under this Act shall be punishable with the same punishment and be liable to be proceeded against in the same manner as if he had committed such offence.

SECTION 10 : “PENALTY FOR HARBOURING SPIES”

If any person whom he knows or has reasonable grounds for supposing to be person who is about to commit or who has committed offence under this Act shall be guilty of offence under this Section.

SECTION 11 : “SEARCH WARRANTS”

If a presidency Magistrate, Magistrate First Class or Sub-Divisional magistrate is satisfied with the information that there is reasonable ground for suspecting that an offence under this Act has been or is about to be committed, he may grant search warrant to any Police Officer to enter at any time any premises to force to search premises or the places.

Note: Based on the Illustrative Format as above, the concerned Dealing Officer / HOD(C) may formulate / design the required forms / documents / tender enquiries / registers / GCC / proformas to suit to the requirements on case to case basis in line with the corresponding articles in Purchase Manual Volume-I.

Proforma Bank Guarantee for Performance Security (PS)**(On Non-Judicial stamp paper of value Rs. 500/-)**

1. IN CONSIDERATION OF MAZAGON DOCK SHIPBUILDERS LIMITED / other Defence Public Sector Shipyards , a company incorporated under the Companies Act 1956 and having its registered office at Dockyard Road, Mumbai 400010 (hereinafter referred to as the "the Purchaser" which expression shall, unless it be repugnant or contrary to the subject or context thereof, be deemed to mean and include its successors and assigns) having placed an order on Messer's a partnership firm/sole proprietor business/a company registered under the Companies Act, 1956 having its office at (hereinafter called the "Contractor/Supplier" which expression shall, unless it be repugnant or contrary to the subject or context thereof, be deemed to mean and include its successors and assigns) vide order No.dtd.....(hereinafter called "the order" which expression shall include any amendments/alterations to "the order" issued by "the Purchaser") for the supply, delivery at site, installation and commissioning of certain equipment, item/services/civil works etc. as stated in the said Order and the Purchaser having agreed with the Contractor/Supplier to accept a Bank Guarantee in lieu of Security Deposit payable under the said order for the fulfilment and performance of the said order, We, Bank having office at..... (hereinafter referred to as "the Bank" which expression shall include its successor and assign) hereby agree to pay to the purchaser without any demur on first demand amount not exceeding Rs.....(Rupees.....only) being 5% of the order value against any loss or damage, costs, charges and expenses cause to or suffered by the purchaser by reason of non-performance and non-fulfilment or for any breach on the part of the Contractor/ Supplier of any of the terms & conditions of the said order.
2. We,.....Bank further agree that the Purchaser shall be sole judge whether the said Contractor/Supplier has failed to perform or fulfil the said order in term thereof or committed breach of any terms and conditions of the order and the extend of loss, damage, cost, charges and expenses suffered or incurred or would be suffered or incurred by the purchaser on account thereof and we waive in the favour of the Purchaser all the right and defences to which we as Guarantors may be entitled to.
3. We,..... Bank further agree that the amount demanded by the Purchaser as such shall be final and binding on the Bank as to the Bank's liability to pay and the amount demanded and the Bank undertake to pay the Purchaser the amount so demanded on first demand and without any demur notwithstanding any dispute raised by the Contractor/Supplier or any suit or other legal proceedings including arbitration pending before any court, tribunal or arbitrator related thereto, our liability under this guarantee being absolute and unconditional.
4. We,.....Bank further agree with the purchaser that the purchaser shall have the fullest liberty without our consent and without affecting in any manner our obligations hereunder to vary any of the terms and conditions of the said order/or to extend time of performance by the Supplier from time to time or to postpone for any time to time any of the power excisable by the Purchaser against the Contractor/ Supplier and to forbear to enforce any of the terms and conditions relating to the order and we shall not be relieved from our liability by reason of any such variation or extension being granted to the Contractor/Supplier or for any forbearance, act or omission on the part of the Purchaser or any indulgence by the Purchaser to the Contractor/Supplier or by any such matter or things whatsoever which under the law relating to sureties would have the effect of relieving us.

5. We,Bank further undertake not to revoke this guarantee during its currency except with the previous consent of the Purchaser in writing.
6. We,.....Bank also agree that the Bank's liability under this guarantee shall not be affected by any change in the constitution of the Contractor/ Supplier or dissolution or winding up of the business of the contractor/supplier.
7. Notwithstanding anything contained herein above:
 - i. Our liability under this guarantee shall not exceed Rs. /-
 - ii. This Bank guarantee shall be valid up to and including _____, and
 - iii. We are liable to pay the guarantee amount or any part thereof under this Bank Guarantee only and only if you serve upon us a written claim or demand on or before _____ (Validity + four weeks from the date of expiry of this guarantee).
8. This Guarantee shall be governed by Indians Laws and the Courts at Mumbai, India shall have the exclusive jurisdiction.

IN WITNESS WHEREOF THE Bank has executed this document on

this..... day of

For Bank

(by its constituted attorney)

(Signature of a person authorized

to sign on behalf of "the Bank")

Declaration by bidder for RESTRICTIONS UNDER RULE 144(XI) OF GENERAL FINANCIAL RULES GFRS, (2017) AS PER DIRECTIVES F NO. DPE/7(4)/2017-FIN DTD 24.02.2023 & ORDER NO F.7/10/2021-PPD (1) DTD 23.02.2023

(On bidder's Letter Head)

I have read the clause regarding restrictions on procurement from a bidder of a country which shares a land border with India; I certify that our Firm M/s..... is not from such a country and does not have any specified Transfer of Technology (TOT) from such a country or, if from such a country or if having specified TOT from such a country has been registered with the Competent Authority.

I hereby certify that our Firm M/s..... fulfills all requirements in this regard and is eligible to be considered for procurement on GeM. [Where applicable, evidence of valid registration by the Competent Authority shall be attached along with this declaration as per the case]

Note – The successful bidder shall not be allowed to sub-contract works to any contractor from a country which shares a land border with India unless such contractor is registered with the Competent Authority. Defence Public Sector Shipyards reserves the right to consider placement of Order / Contract or reject any or all tenders/Orders without assigning any reason.

COMPANY'S NAME & ADDRESS:

SIGNATURE:

DATE:

NAME:

DESIGNATION:

BIDDER'S COMPANY SEAL:

INTEGRITY PACT

Mazagon Dock Shipbuilders Limited (MDL) hereinafter referred to as "**The Principal/Buyer**"

And.....hereinafter referred to as "**The Bidder/ Contractor**"

PREAMBLE

The Principal/Buyer intends to award, under laid down organizational procedures, contract/s for.....The Principal/Buyer values full compliance with all relevant laws of the land rules, regulations, economic use of resources and of fairness / transparency in its relations with its Bidder(s) and /or Contractor(s).

In order to achieve these goals, the Principal/Buyer will appoint an Independent External Monitor (IEM), who will monitor the tender process and the execution of the contract for compliance with the principles mentioned above.

Section 1 - Commitments of the Principal/Buyer:

(1)	The Principal/Buyer commits itself to take all measures necessary to prevent corruption and to observe the following principles:	
	a)	No employee of the Principal/Buyer, personally or through family members, will in connection with the tender for, or the execution of a contract, demand, take a promise for or accept, for self or third person, any material or immaterial benefit which the person is not legally entitled to.
	b)	The Principal/Buyer will during the tender process treat all Bidder(s) with equity and reason. The Principal/Buyer will in particular, before and during the tender process, provide to all Bidder(s) the same information and will not provide to any Bidder(s) confidential/additional information through which the Bidder(s) could obtain an advantage in relation to the tender process or the contract execution.
	c)	The Principal/Buyer will exclude from the process all known prejudiced persons.
	d)	The Principal/Buyer undertakes to scrupulously follow the tender containing General Conditions of Contract (GCC) in respect of procurement contracts for goods, services and civil works.
(2)	If the Principal/Buyer obtains information on the conduct of any of its employees which is a criminal offence under the relevant Anti-Corruption Laws of India, or if there be a substantive suspicion in this regard, the Principal/Buyer will inform the Chief Vigilance Officer, MDL and in addition can initiate disciplinary actions.	

Section 2 - Commitments of the Bidder(s)/Contractor(s):

(1)	The Bidder(s)/Contractor(s) commit himself to take all measures necessary to prevent corruption. He commits himself to observe the following principles during his participation in the tender process and during the contract execution.	
	a)	The Bidder(s)/Contractor(s) will not, directly or through any other persons or firm, offer promise or give to any of the Principal/Buyer's employees involved in the tender process or the execution of the contract or to any third person any material or other benefit which he/she is not legally entitled to, in order to obtain in exchange any advantage or any kind whatsoever during the tender process or during the execution of the contract.
	b)	The Bidder(s)/Contractor(s) will not enter with other Bidders into any undisclosed agreement or understanding, whether formal or informal. This applies in particular to prices, specifications, certifications, subsidiary contracts, submission or non-submission of bids or any other actions to restrict competitiveness or to introduce cartelization in the bidding process.
	c)	The Bidder(s)/Contractor(s) will not commit any offence under the relevant Anti-Corruption Laws of India; further the Bidder(s)/Contractor(s) will not use improperly, for purposes of competition or personal gain, or pass on to other, any information or document provided by the Principal/Buyer as part of the business relationship, regarding plans, technical proposals and business details, including information contained or transmitted electronically.
	d)	The Bidder(s)/Contractor(s) of foreign origin shall disclose the name and address of the Agents/representatives in India, if any. Similarly, the Bidder(s)/Contractor(s) of Indian Nationality shall furnish the name and address of the foreign principals, if any. All payments made to the Indian Agent/representative have to be in Indian Rupees only. Further details as mentioned in the "Guidelines of Indian Agents of Foreign suppliers" shall be disclosed by the Bidders(s)/Contractor(s). Copy of the "Guidelines on Indian Agents of Foreign Suppliers" as annexed and marked as Annexure-A.
	e)	The Bidder(s)/Contractor(s) will when presenting his bid, disclose any and all payments he has made, is committed to or intends to make to agents, brokers or any other intermediaries in connection with the award of the contract.
	f)	The Bidder (s)/Contractor(s), their agents, representatives shall not do such things so as to interfere with the procedures laid down in the Principal/Buyer's tender containing the General Conditions of Contract (GCC) in respect of procurement contracts for goods, services and civil works.
	g)	The Bidder commits to refrain from giving any complaint directly or through any other manner without supporting it with full and verifiable facts.
(2)	The Bidder(s)/Contractor(s) will not instigate third persons to commit offences outlines above or be an accessory to such offences.	
(3)	A person signing IP shall not approach the courts while representing the matters to IEMs and he/she will await their decision in the matter.	

Section 3 - Disqualification from tender process and exclusion from future contracts:

	If the Bidder(s)/Contractor(s) before contract award or during execution of Contract has committed a transgression through a violation of Section 2, above or in any other form such as to put his reliability or credibility as Bidder(s) in question, the Principal/Buyer is entitled to disqualify the Bidder(s)/Contractor(s) from the tender process or to terminate the contract, if already signed for such reason, as per the procedure mentioned in the "Guidelines on Banning of business dealings" Copy of the "Guidelines on Banning of business dealings" is annexed and marked as Annexure-B.
1)	If the Bidder(s)/Contractor(s) has committed a transgression through a violation of Section 2 such as to put his reliability or credibility into question, the Principal/Buyer is entitled also to exclude the Bidder(s)/Contractor(s) from future contract award processes. The imposition and duration of the exclusion will be determined by the severity of the transgression. The severity will be determined by the circumstances of the case, in particular the number of transgressions, the position of the transgressors within the company hierarchy of the Bidder(s) and the amount of the damage. The exclusion will be imposed for a minimum of six months and maximum of five years, which may be further extended at the discretion of the Principal/Buyer.
2)	A transgression is considered to have occurred, if the Principal/Buyer after due consideration of the available evidence, concludes that no reasonable doubt is possible.
3)	The Bidder (s) accepts and undertakes to respect and uphold the Principal/Buyer's absolute right to resort to and impose such exclusion and further accepts and undertakes not to challenge or question such exclusion on any ground, including the lack of any hearing before the decision to resort to such exclusion is taken. This undertaking is given freely and after obtaining legal advice.
4)	If the Bidder(s)/Contractor(s) can prove that he has restored/ recouped the damage caused by him and has installed a suitable corruption prevention system, the Principal/Buyer may revoke the exclusion prematurely.

Section 4 – Sanctions for Violation:

(1)	Any breach of the aforesaid provisions by the Bidder or any one employed by him or acting on his behalf (whether with or without the knowledge of the Bidder) or the commission of any offence by the Bidder or any one employed by him or acting on his behalf, as defined in Chapter IX of the Indian Penal Code, 1860 or the Prevention of Corruption Act 1988 or any other Act enacted for the prevention of corruption shall entitle the Principal/Buyer to take all or any one of the following actions, wherever required –
a)	To immediately call off the pre-contract negotiations without assigning any reason or giving any compensation to the Bidder. However, the proceedings with the other Bidder (s) would continue.
b)	The Earnest Money Deposit/Security Deposit/Performance Bond shall stand forfeited either fully or partially, as decided by the Principal/Buyer, and the Principal/Buyer shall not be required to assign any reason there for.

c)	To immediately cancel the contract, if already signed, without giving any compensation to the Bidder.
d)	To recover all sums already paid by the Principal/Buyer, in case of an Indian Bidder with interest thereon at 2% higher than the prevailing Base Rate of SBI, and in case of a Bidder from a country other than India with interest thereon at 2% higher than the LIBOR. If any outstanding payment is due to the Bidder from the Buyer in connection with any other contract for any other Defence stores, such outstanding payment could also be utilized to recover the aforesaid sum and interest.
e)	To en-cash the advance Bank Guarantee and Performance Bond/Warranty bond, if furnished by the Bidder, in order to recover the payments, already made by the Principal/Buyer, along with interest.
f)	To cancel all or any other contracts with the Bidder.
g)	To debar the Bidder from entering into any bid from Principal/Buyer for a minimum period of five years, which may be further extended at the discretion of the Principal/Buyer.
h)	To recover all sums paid in violation of this Pact by Bidder(s) to any middleman or agent or broker with a view to securing the contract.
i)	If the Bidder or any employee of the Bidder or any person acting on behalf of the Bidder, either directly or indirectly, is closely related to any of the officers of the Buyer, or alternatively, if any close relative of an officer of the Buyer has financial interest/stake in the Bidder's firm, the same shall be disclosed by the Bidder at the time of filing of tender. Any failure to disclose the interest involved shall entitle the Buyer to rescind the contract without payment of any compensation to the Bidder.
	The term 'close relative' for this purpose would mean spouse whether residing with the Principal/Buyer's employee/employees or not, but not include a spouse separated from the Principal/Buyer's employee/employees by a decree or order of a competent court; son or daughter or step son or step daughter and wholly dependent upon Principal/Buyer's employee/employees, but does not include a child or step child who is no longer in any way dependent upon the Principal/Buyer's employee/employees or of whose custody the Principal/Buyer's employee/employees has been deprived of by or under any law; any other person related, whether by blood or marriage, to the Principal/Buyer's employee/employees or to the Principal/Buyer's employee/employees wife or husband and wholly dependent upon Principal/Buyer's employee/employees.
j)	The Bidder shall not lend to or borrow any money from or enter into any monetary dealings or transactions, directly or indirectly, with any employee of the Principal/Buyer, and if he does so, the Principal/Buyer shall be entitled forthwith to rescind the contract and all other contracts with the Bidder. The Bidder shall be liable to pay compensation for any loss or damage to the Principal/Buyer resulting from such rescission and the Principal/Buyer shall be entitled to deduct the amount so payable from the money(s) due to the Bidder.
l)	In cases where Irrevocable Letters of Credit have been received in respect of any contract signed by the Principal/Buyer with the Bidder, the same shall not be opened.

(2)	The decision of the Principal/Buyer to the effect that a breach of the provisions of this Integrity Pact has been committed by the Bidder shall be final and binding on the Bidder, however, the same Bidder can approach the Monitor(s) appointed for the purposes of this Pact.
-----	---

Section 5 - Previous Transgression:

(1)	The Bidder declares that no previous transgressions occurred in the last three years with any other company in any country conforming to the anti-corruption approach or with any other public sector enterprise in India that could justify his exclusion from the tender process.
(2)	If the bidder makes incorrect statement on this subject, he can be disqualified from the tender process or further action can be taken.

Section 6 - Equal treatment of all Bidders/Contractor(s)/Subcontractors:

(1)	The Bidder(s)/Contractor(s) undertake(s) to demand from all subcontractors a commitment in conformity with this integrity Pact, and to submit it to the Principal before contract signing.
(2)	The Principal/Buyer will enter into agreements with identical conditions as this one with all bidders, contractors and subcontractors. In case of a joint venture, all partner of the joint venture should sign the Integrity pact. In case of sub-contracting, the principle contractor shall be solely responsible for the adherence to the provisions of IP by the sub-contractor(s).
(3)	The Principal/Buyer will disqualify from the tender process all bidders who do not sign this Pact or violate its provisions.

Section 7 - Criminal charges against violation Bidder(s)/Contractor(s)/ Subcontractor(s):

(1)	If the Principal/Buyer obtains knowledge of conduct of a Bidder, Contractor or subcontractor, or of an employee or a representative or an associate of a Bidder, Contractor of subcontractor which constitutes corruption or if the Principal has substantive suspicion in this regard, the Principal/Buyer will inform the same to the Chief Vigilance Officer, MDL.
-----	---

Section 8 - Independent External Monitor/Monitors:

(1)	The Principal/Buyer appoints competent and credible independent External Monitor for this Pact. The task of the Monitor is to review independently and objectively whether and to what extent the parties comply with the obligations under this agreement.
(2)	The Monitor is not subject to instructions by the representatives of the parties and performs his functions neutrally and independently. He reports to the Chairman & Managing Director of the Principal/Buyer.
(3)	The Bidder(s)/Contractor(s) accepts that the Monitor has the right to access without restriction to all project documentation of the Principal/Buyer including that provided by the Contractor. The Contractor will also grant the Monitor, upon his request and demonstration

	of a valid interest, unrestricted and unconditional access to his project documentation. The same is applicable to Subcontractors. The Monitor is under contractual obligation to treat the information and documents of the Bidder(s)/Contractor(s)/Subcontractor(s) with confidentiality
(4)	The Principal/Buyer will provide to the Monitor sufficient information about all meetings among the parties related to the Project provided such meetings could have an impact on the contractual relations, between the Principal/Buyer and the Contractor. The parties offer to the Monitor the option to participate in such meetings.
(5)	As soon as the Monitor notices, or believes to notice, a violation of this agreement, he will so inform the Management of the Principal/Buyer and request the Management to discontinue or take corrective action, or to take other relevant action. The Monitor can in this regard submit non-binding recommendations. Beyond this, the Monitor has no right to demand from the parties that they act in a specific manner, refrain from action or tolerate action. However, the Monitor shall give an opportunity to the Bidder(s)/Contractor(s) to present its case before making its recommendation to the Principal/Buyer.
(6)	The Monitor will submit a written report to the Chairman & Managing Director of the Principal within 8 to 10 weeks from the date of reference or intimation to him by the Principal/Buyer and, should the occasion arise, submit proposals for correcting problematic situations.
(7)	Monitor shall be entitle to compensation on the same terms as being extended to / provided to Independent Directors on the Board of Principal/Buyer.
(8)	If the Monitor has reported to the Chairman & Managing Director of the Principal, a substantiated suspicion of an offence under relevant Anti-Corruption Laws of India and the Chairman & Managing Director of the Principal/Buyer has not, within the reasonable time taken visible action to proceed against such offence or reported it to the Chief Vigilance Officer, the Monitor may also transmit this information directly to the Central Vigilance Commissioner, Government of India.
(9)	The word 'Monitor' would include both singular and plural.

Section 9 - Pact Duration:

	<p>This pact begins when both parties have legally signed it. It expires for the Contractor 12 months after the last payment under the contract and for all other Bidders 06 months after the contract has been awarded.</p> <p>If any claim is made / lodged during this time, the same shall be binding and continue to be valid despite the lapse of this pact as specified above unless it is discharged / determined by Chairman & Managing Director of the Principal/Buyer.</p>
--	---

Section 10 - Other provisions:

(1)	This agreement is subject to Indian Law, place of performance and jurisdiction is the Registered Office of the Principal/Buyer, i.e. Mumbai (For MDL). The Arbitration clauses
-----	--

	provided in the main tender document/ contract shall not be applicable for any issue/dispute arising under this Integrity pact.
(2)	Changes and supplements as well as termination notices need to be made in writing. Side agreements have not been made.
(3)	If the Contractor is a partnership or a consortium, this agreement must be signed by all partners or consortium members.
(4)	Should one or several provisions of this agreement turn out to be invalid, the remainder of this agreement remains valid. In this case, the parties will strive to come to an agreement to their original intentions.

Section 11 – Fall Clause: #

“The Bidder undertakes that it has not supplied/is not supplying similar products/ systems or subsystems at a price lower than that offered in the present bid in respect of any other Ministry/Department of the Government of India or PSU and if it is found at any stage that similar product/systems or sub systems was supplied by the Bidder to any other Ministry/Department of the Government of India or a PSU at a lower price, then that very price, with due allowance of elapsed time, will be applicable to the present case and the difference in the cost would be refunded by the Bidder to the Principal/Buyer, if the contract has already been concluded.”

For & on behalf of

MAZAGON DOCKSHIPBUILDERS LIMITED

(OFFICE SEAL)

Place_____

Date_____

For & on behalf of

Bidder/Contractor

(OFFICE SEAL)

Witness 1:

(Name & Address)

Witness 2:

(Name & Address)

GUIDELINES FOR INDIAN AGENTS OF FOREIGN SUPPLIERS

1.0	There shall be compulsory registration of agents for all Global (Open) Tender and Limited Tender. An agent who is not registered with MDL shall apply for registration.
1.1	An agent shall represent only one Foreign Supplier and not represent two suppliers or quote on their behalf in the same tender.
	However, either the Indian Agent on behalf of the Foreign Suppliers (also includes foreign manufacturers) or the Foreign Suppliers (also includes foreign manufacturers) directly could bid in a tender, but not both. In cases where an agent participates in a tender on behalf of one manufacturer, shall not quote on behalf of another manufacturer along with the first Manufacturer in a subsequent/parallel tender for the same item.
1.2	Registered agents will file an authenticated Photostat copy duly attested by a Notary Public/Original certificate of the principal confirming the agency agreement and giving the status being enjoyed by the agent and the commission/remuneration/salary/ retainer ship being paid by the principal to the agent before the placement of order by MDL.
1.3	Wherever the Indian representatives have communicated on behalf of their principals and the foreign parties have stated that they are not paying any commission to the Indian agents, and the Indian representative is working on the basis of salary or as retainer, a written declaration to this effect should be submitted by the party (i.e. Principal) before finalizing the order.

2.0 DISCLOSURE OF PARTICULARS OF AGENTS/ REPRESENTATIVES IN INDIA, IF ANY

2.1	Tenderers of Foreign nationality shall furnish the following details in their offer:	
	2.1.1	The name and address of the agents/representatives in India, if any and the extent of authorization and authority given to commit the Principals. In case the agent/representative be a foreign Company, it shall be confirmed whether it is real substantial Company and details of the same shall be furnished.
	2.1.2	The amount of commission/remuneration included in the quoted price(s) for such agents/representatives in India
	2.1.3	Confirmation of the Tenderer that the commission/ remuneration if any, payable to his agents/ representatives in India, may be paid by MDL in Indian Rupees only.
2.2	Tenderers of Indian Nationality shall furnish the following details in their offers:	

	2.2.1	The name and address of the foreign principals indicating their nationality as well as their status, i.e, whether manufacturer or agents of manufacturer holding the Letter of Authority of the Principal specifically authorizing the agent to make an offer in India in response to tender either directly or through the agents/representatives.
	2.2.2	The amount of commission/remuneration included in the price (s) quoted by the Tenderer for himself.
	2.2.3	Confirmation of the foreign principals of the Tenderer that the commission / remuneration, if any, reserved for the Tenderer in the quoted price (s), may be paid by MDL in India in equivalent Indian Rupees on satisfactory completion of the Project or supplies of Stores and Spares in case of operation items
2.3	In either case, in the event of contract materializing, the terms of payment will provide for payment of the commission /remuneration, if any payable to the agents/representatives in India in Indian Rupees on expiry of 90 days after the discharge of the obligations under the contract.	
2.4	Failure to furnish correct and detailed information as called for in paragraph-2.0 above will render the concerned tender liable to rejection or in the event of a contract materializing, the same liable to termination by MDL. Besides this there would be a penalty of banning business dealings with MDL or damage or payment of a named sum.	

GUIDELINES ON BANNING OF BUSINESS DEALINGS CONTENTS

Sr.	Description
1.	Introduction
2	Scope
3.	Definitions
4.	Initiation of Banning / Suspension
5.	Suspension of Business Dealings
6.	Ground on which Banning of Business Dealing can be initiated
7.	Banning of Business Dealings
8.	Removal from List of Approved Agencies-Suppliers/ Contractors etc.
9.	Procedure for issuing Show-cause Notice
10.	Appeal against the Decision of the Competent Authority
11.	Review of the Decision by the Competent Authority
12.	Circulation of the names of Agencies with whom Business Dealings have been banned

1. Introduction

1.1	Mazagon Dock Shipbuilders Limited (MDL), being a Public Sector Enterprise and 'State', within the meaning of Article 12 of Constitution of India, has to ensure preservation of rights enshrined in Chapter III of the Constitution. MDL as also to safeguard its commercial interests. MDL deals with Agencies, who have a very high degree of integrity, commitments and sincerity towards the work undertaken. It is not in the interest of MDL to deal with Agencies who commit deception, fraud or other misconduct in the execution of contracts awarded / orders issued to them. In order to ensure compliance with the constitutional mandate, it is incumbent on MDL to observe principles of natural justice before banning the business dealings with any Agency.
1.2	Since banning of business dealings involves civil consequences for an Agency concerned, it is incumbent that adequate opportunity of hearing is provided and the explanation, if tendered, is considered before passing any order in this regard keeping in view the facts and circumstances of the case.

2. Scope

2.1	MDL reserves its rights to remove from list of approved suppliers / contractors or to ban business dealings if any Agency has been found to have committed misconduct and also to suspend business dealings pending investigation.
2.2	Similarly, in case of sale of material there is a clause to deal with the Agencies / customers / buyers, who indulge in lifting of material in unauthorized manner.
2.3	However, absence of such a clause does not in any way restrict the right of MDL to take action / decision under these guidelines in appropriate cases.
2.4	The procedure of (i) Removal of Agency from the List of approved suppliers / contractors; (ii) Suspension and (iii) Banning of Business Dealing with Agencies, has been laid down in these guidelines.
2.5	These guidelines apply to all the Divisions/Yards of MDL.
2.6	It is clarified that these guidelines do not deal with the decision of the Management not to entertain any particular Agency due to its poor / inadequate performance or for any other reason.
2.7	The banning shall be with prospective effect, i.e., future business dealings.

3. Definitions

In these Guidelines, unless the context otherwise requires:

i)	'Bidder / Contractor / Supplier / Purchaser / Customer' shall mean and include a public limited company or a private limited company, a firm whether registered or not, an individual, a cooperative society or an association or a group of persons engaged in any commerce, trade, industry, etc. 'Bidder / Contractor / Supplier / Purchaser / Customer' in the context of these guidelines is indicated as 'Agency'.	
ii)	'Inter-connected Agency' shall mean two or more companies having any of the following features:	
	a)	If one is a subsidiary of the other.
	b)	If the Director(s), Partner(s), Manager(s) or Representative(s) are common;
	c)	If management is common;
	d)	If one owns or controls the other in any manner;
iii)	'Competent Authority' and 'Appellate Authority' shall mean the following:	

	a)	Functional Director shall be the 'Competent Authority' for the purpose of these guidelines. CMD, MDL shall be the 'Appellate Authority'.
	b)	CMD, MDL shall have overall power to take suo-moto action on any information available or received by him and pass such order(s) as he may think appropriate, including modifying the order(s) passed by any authority under these guidelines.
iv)		'Investigating Department' shall mean any Department or Unit investigating into the conduct of the Agency and shall include the Vigilance Department, Central Bureau of Investigation, the State Police or any other department set up by the Central or State Government having powers to investigate.
v)		'List of approved Agencies – 'Bidder / Contractors / Suppliers / Purchasers / Customers shall mean and include list of approved / registered Agencies - 'Bidder / Contractors / Suppliers / Purchasers / Customers, etc.

4. Initiation of Banning / Suspension

	Action for banning / suspension business dealings with any Agency should be initiated by the department having business dealings with them after noticing the irregularities or misconduct on their part. Besides the concerned department, Vigilance Department may also be competent to initiate such action.
--	---

5. Suspension of Business Dealings

5.1	If the conduct of any Agency dealing with MDL is under investigation by any department, the Competent Authority may consider whether the allegations under investigation are of a serious nature and whether pending investigation, it would be advisable to continue business dealing with the Agency. If the Competent Authority, after consideration of the matter including the recommendation of the Investigating Department, if any, decides that it would not be in the interest to continue business dealings pending investigation, it may suspend business dealings with the Agency. The order to this effect may indicate a brief of the charges under investigation. If it is decided that inter-connected Agencies would also come within the ambit of the order of suspension, the same should be specifically stated in the order. The order of suspension would operate for a period not more than six months and may be communicated to the Agency as also to the Investigating Department. The Investigating Department may ensure that their investigation is completed and whole process of final order is over within such period.
5.2	The order of suspension shall be communicated to all Commercial Departmental Heads. During the period of suspension, no business dealing may be held with the Agency.
5.3	As far as possible, the existing contract(s) with the Agency may continue unless the Competent Authority, having regard to the circumstances of the case, decides otherwise.

5.4	If the gravity of the misconduct under investigation is very serious and it would not be in the interest of MDL, as a whole, to deal with such an Agency pending investigation, the Competent Authority may order suspension of business dealing with Agency and send his recommendation to Chief Vigilance Officer (CVO), MDL along with the material available, copy of which may be issued to the Agency concerned with intimation to CVO MDL. Such an order would operate for a period of six months from the date of issue.
5.5	If the Agency concerned asks for detailed reasons of suspension, the Agency may be informed that its conduct is under investigation. It is not necessary to enter into correspondence or argument with the Agency at this stage.
5.6	It is not necessary to give any show-cause notice or personal hearing to the Agency before issuing the order of suspension. However, if investigations are not complete in six months' time, the Competent Authority may extend the period of suspension by another three months, during which period the investigations must be completed.

6. Ground on which Banning of Business Dealings can be initiated

6.1	If the security consideration, including questions of loyalty of the Agency to the State, so warrants;
6.2	If the Director / Owner of the Agency, proprietor or partner of the firm, is convicted by a Court of Law for offences involving moral turpitude in relation to its business dealings with the Government or any other public sector enterprises or MDL, during the last five years;
6.3	If there is strong justification for believing that the Directors, Proprietors, Partners, owner of the Agency have been guilty of malpractices such as bribery, corruption, fraud, substitution of tenders, interpolations, etc;
6.4	If the Agency continuously refuses to return / refund the dues of MDL without showing adequate reason and this is not due to any reasonable dispute which would attract proceedings in arbitration or Court of Law;
6.5	If the Agency employs a public servant dismissed / removed or employs a person convicted for an offence involving corruption or abetment of such offence;
6.6	If business dealings with the Agency have been banned/blacklisted by Government Agencies/ Statutory bodies, DGQA, Defence Public Sector Shipyards , DPSUs or with whom commercial transactions have been suspended for sufficient and justifiable reasons.
	If the Agency having same promoters/Directors /Partners as the barred/blacklisted Company as at 6.6 above for the duration for which the barring/ blacklisting of sister concern persists.

6.7	<p>If the Agency has resorted to Corrupt, fraudulent practices including misrepresentation of facts;</p> <p>If the agency who had fraudulently dealt with the Company for pecuniary gains or had connived with dealing officers for mutual benefit.</p>
6.8	If the Agency uses intimidation / threatening or brings undue outside pressure on the MDL or its official in acceptance / performances of the job under the contract;
6.9	If the Agency indulges in repeated and / or deliberate use of delay tactics in complying with contractual stipulations;
6.10	Wilful indulgence by the Agency in supplying sub-standard material irrespective of whether pre-dispatch inspection was carried out by MDL or not;
6.11	Based on the findings of the investigation report of CBI / Police against the Agency for malafide / unlawful acts or improper conduct on his part in matters relating to the MDL or even otherwise;
6.12	Established litigant nature of the Agency to derive undue benefit;
6.13	Continued poor performance of the Agency in several contracts;
6.14	<p>If the Agency misuses the premises or facilities of the MDL, forcefully occupies, tampers or damages the Company's properties including land, water resources, forests / trees, etc.</p> <p>If the Agency who knowingly collude to defeat competition with the aim of deriving undeserved profit or gain from doing business with MDL.</p> <p>(Note: The examples given above are only illustrative and not exhaustive. The Competent Authority may decide to ban business dealing for any good and sufficient reason).</p>

7. Banning of Business Dealings

7.1	Decision to ban business dealings with any Agency would apply throughout the Company.		
7.2	<p>There will be a Standing Committee to be appointed by the CMD which may include HOD of respective Commercial Section/Capital Works/OTS, HOD (M), rep of Legal Dept. and OIC (SR&R) for processing the cases of "Banning of Business Dealings". The functions of the committee shall, inter-alia include:</p>		
	<table border="1"> <tr> <td>i)</td> <td>To study the report of the Investigating Agency and decide if a prima-facie case for banning exists, if not, send back the case to the Competent Authority.</td> </tr> </table>	i)	To study the report of the Investigating Agency and decide if a prima-facie case for banning exists, if not, send back the case to the Competent Authority.
i)	To study the report of the Investigating Agency and decide if a prima-facie case for banning exists, if not, send back the case to the Competent Authority.		

	ii)	To recommend for issue of show-cause notice to the Agency by the concerned department
	iii)	To examine the reply to show-cause notice and call the Agency for personal hearing, if required.
	iv)	To submit final recommendation to the Competent Authority for banning or otherwise.
7.3	If the Competent Authority is prima-facie of view that action for banning business dealings with the Agency is called for, a show-cause notice may be issued to the Agency as per paragraph 9.1 and an enquiry held accordingly.	

8. Removal from List of Approved Agencies - Suppliers / Contractors, etc

8.1	If the Competent Authority decides that the charge against the Agency is of a minor nature, it may issue a show-cause notice as to why the name of the Agency should not be removed from the list of approved Agencies - Suppliers / Contractors, etc.	
8.2	The effect of such an order would be that the Agency would not be disqualified from competing in Open Tender Enquiries but LTE may not be given to the Agency concerned.	
8.3	Past performance of the Agency may be taken into account while processing for approval of the Competent Authority for awarding the contract.	

9. Show-cause Notice

9.1	In case where the Competent Authority decides that action against an Agency is called for, a show-cause notice has to be issued to the Agency. Statement containing the imputation of misconduct or misbehavior may be appended to the show-cause notice and the Agency should be asked to submit within 15 days a written statement in its defence.	
9.2	If the Agency requests for inspection of any relevant document in possession of MDL, necessary facility for inspection of documents may be provided.	
9.3	The Competent Authority may consider and pass an appropriate speaking order:	
	a)	For exonerating the Agency if the charges are not established;
	b)	For removing the Agency from the list of approved Suppliers / Contractors, etc.
	c)	For banning the business dealing with the Agency.

9.4	If it decides to ban business dealings, the period for which the ban would be operative may be mentioned. The order may also mention that the ban would extend to the interconnected Agencies of the Agency.
-----	--

10. Appeal against the Decision of the Competent Authority

10.1	The Agency may file an appeal against the order of the Competent Authority banning business dealing, etc. The appeal shall lie to Appellate Authority. Such an appeal shall be preferred within one month from the date of receipt of the order banning business dealing, etc.
10.2	Appellate Authority would consider the appeal and pass appropriate order which shall be communicated to the Agency as well as the Competent Authority.

11. Review of the Decision by the Competent Authority

	Any petition / application filed by the Agency concerning the review of the banning order passed originally by Competent Authority under the existing guidelines either before or after filing of appeal before the Appellate Authority or after disposal of appeal by the Appellate Authority, the review petition can be decided by the Appellate Authority upon disclosure of new facts / circumstances or subsequent development necessitating such review. The Competent Authority may refer the same petition to the separate Standing Committee which may be constituted by Appellate Authority for examination and recommendation.
--	--

12. Circulation of the names of Agencies with whom Business Dealings have been banned

12.1	Depending upon the gravity of misconduct established, the Competent Authority may direct HOD (Materials)/OIC (SR&R) to circulate the names of Agency with whom business dealings have been banned, to the Government Departments, other Public Sector Enterprises, etc. for such action as they deem appropriate
12.2	If Government Departments or a Public Sector Enterprise request for more information about the Agency with whom business dealings have been banned, a copy of the report of Inquiring Authority together with a copy of the order of the Competent Authority / Appellate Authority may be supplied.
12.3	If business dealings with any Agency have been banned by the Central or State Government or any other Public Sector Enterprise, MDL may, without any further enquiry or investigation, issue an order banning business dealing with the Agency and its inter-connected Agencies

NON DISCLOSURE AGREEMENT

This NON DISCLOSURE Agreement made at Mumbai, India on this _____ day of _____ 2014 between Mazagon Dock Shipbuilders Limited a company registered under the Companies Act, 1956 and having its registered office at Dockyard Road, Mumbai-400 010 (hereinafter referred to as "MDL") and _____ a company registered under the Companies Act, 1956 and having its registered office at _____ (hereinafter referred to as "_____"). MDL and _____ shall hereinafter be collectively referred to as "the Parties" and individually as "a Party".

WHEREAS

- b) MDL has floated a tender and is required to provide certain information to (name of the bidder) to prepare his bid and/or
- B. The Parties intend that the aforesaid information be kept confidential as between the Parties. The Parties undertake and declare that they shall not divulge, publish or reproduce the same before any party or person except in accordance with the terms of this Agreement.

NOW THEREFORE the Parties agree as follows:

- b) As used in this Agreement (hereinafter referred to as the "Agreement") the term "Confidential Information" shall mean any technical, confidential, proprietary or trade secret information or data disclosed by the Disclosing Party in connection with the _____ to the Receiving Party including without limitation any written or printed documents, specifications for the vessel, plans, general arrangement plans, production schedules, drawings, samples, models, information regarding business operations, financial information, marketing strategies, either in writing or orally or any means of disclosing such Confidential Information that the Disclosing Party may elect to use prior to the execution or during the validity of this Agreement. The Receiving Party agrees that all Confidential Information shall be treated as absolute confidential and the Receiving Party shall not disclose to any person such information otherwise than in terms of this Agreement. The Receiving Party will impose a similar duty of confidentiality on any person to whom the Receiving Party is permitted to transfer such information in accordance with the terms hereof.

For the purposes of this Agreement, the term "Receiving Party" shall mean and include its officers, employees, directors, agents, contractors, representatives, affiliated companies, successors and assigns.

2. Nothing in this Agreement may be construed as compelling the Disclosing Party to disclose any Confidential Information to the Receiving Party or to enter into any contractual relationships with the Receiving Party.
3. Any information or data in whatever form disclosed by the Disclosing Party to the Receiving Party and which (i) is clearly identified as Confidential Information by an appropriate and conspicuous marking or (ii) has been identified as Confidential Information at the time of disclosure shall be subject to the relevant terms and conditions of this Agreement. The Disclosing Party's decision whether any information disclosed by it under this Agreement is confidential or not shall be final and binding on the Receiving Party.

4. The Receiving Party hereby covenants that the Confidential Information received from the Disclosing Party shall:

(a) Be safely kept by the Receiving Party; the Receiving Party shall protect the Confidential Information with the same degree of care as the Receiving Party uses with its own confidential information in order to prevent its disclosure, copy and / or its use (but in no event less than reasonable care) for purposes other than the Proposal.

(b) Be only disclosed to, and used by, those employees or directors who have a need to know.

I Not be disclosed to a third party except those with a need to know provided they receive such information subject to the same restrictions as are contained in this Agreement.

(d) Be used by the Receiving Party directly or indirectly, solely for the purpose of considering, evaluating and effecting the tender/bid/contract.

5. The Receiving Party shall promptly upon requests by the Disclosing Party at any time return all copies of the Confidential Information communicated to it hereunder together with all copies and extracts made thereof and shall not retain any copies of the same, in any form whatsoever.

6. The Receiving Party shall have no obligations or restrictions with respect to:

(a) Information publicly known through no wrongful act of the Receiving Party.

(b) Information rightfully disclosed by a third party without breach of this Agreement by the Receiving Party and which can be communicated without restriction.

I Information which was already known or which was independently developed by the Receiving Party (provided that the Receiving Party can demonstrate the same).

(d) Information, the disclosure of which the Disclosing Party authorizes in writing.

7. Nothing in this Agreement shall be construed as granting to the Receiving Party any patent, copyright or design license, or rights of use under similar intellectual property rights in respect of the Confidential Information.

8. The Receiving Party shall not without prior written consent of the Disclosing Party:

(a) Disclose to any person, directly or indirectly:

i) The fact that the Confidential Information has been made available to the Receiving Party by the Disclosing Party or that the Receiving Party has inspected any portion of the Confidential Information; or

ii) The fact that any discussion or negotiation is taking place concerning the Proposal; or

iii) Any of the terms, conditions or other facts with respect to the Proposal, including the status thereof; or

(b) Make any private or public announcement or statement concerning or relating to the Proposal.

9. The Disclosing Party represents and warrants that save as otherwise notified in writing to the Receiving Party:

- a) Disclosure of information by it to the Receiving Party does not infringe the rights of any third party nor is it under any restriction with regard to the disclosure of any information, and that where applicable, it has obtained all licenses and consents necessary to enable the lawful disclosure of information by it to the Recipient; and
- b) It is not aware of any restriction on the use of such information by the Receiving Party, save as provided in this Agreement.
- c) To the effect that the foregoing representations and warranties shall be deemed to be given at the date of this Agreement and after that date upon and in respect of each disclosure.

The Disclosing Party makes no warranty or representation whatsoever as to the accuracy, completeness, suitability or adequacy of any information or as to the results obtained from it and assumes no responsibility in respect of the use of the information by the Receiving Party.

10. The Receiving Party shall indemnify and hold harmless the Disclosing Party from and against any action, claim or proceeding and any loss, damage, costs, expenses or liabilities arising out of any such action, claim or proceeding, brought by any third party pursuant to any unauthorized disclosure or use of any information by the Receiving Party, or by any person for whom the Receiving Party is responsible under this Agreement, or pursuant to any breach of any undertaking, warranty or representation contained in this Agreement.

11. For the purposes of this Agreement 'Classified Information' shall mean information, documents and material of any kind which the respective Government i.e. Indian Government has given or caused to be given a security classification irrespective of whether the same is transmitted orally, electronically, in writing or by hand. Notwithstanding any other provision of this Agreement:

- a) Each Party hereto undertakes to follow security procedures prescribed for military purposes with respect to disclosure, receipt, production, use and handling of Classified Information.
- b) Any Classified Information, disclosed by one Party hereto shall be, whatever the method of disclosure be, identified by the Disclosing Party as Classified Information at the time of disclosure.
- c) The provisions of this Clause are to remain in full force and effect notwithstanding any termination by expiration or otherwise of this Agreement.

12. In the event the Receiving Party is required to disclose Confidential Information under any provision of law or upon an action, subpoena or order of a court of competent jurisdiction or of any requirement of legal process regulation or governmental order, decree, regulation or rule, the Receiving Party will immediately notify the Disclosing Party of its having received a request to so disclose (along with the terms and circumstances thereof), unless otherwise prohibited by law and consult with the Disclosing Party on action or steps to be taken in response to such request.

13. This Agreement represents the entirety of the agreement of the Parties relating to the disclosure of the Confidential Information and shall not be waived, amended or assigned by the Receiving Party except by prior written consent of the Disclosing Party. No failure or delay by any party in exercising any right, power or privilege hereunder shall operate as a waiver

thereof nor shall any single or partial exercise of any right, power or privilege. The rights and remedies herein provided shall be cumulative and not exclusive of any rights or remedies provided by law.

14. This Agreement shall be valid for a period of TWO (02) years from the date of its execution between the parties. Notwithstanding the aforesaid, the obligations of Parties in connection with confidentiality under this Agreement shall survive in perpetuity.
15. The foregoing constitutes the entire Agreement between the Parties with respect to the subject matter hereof and supersedes and cancels any prior representation, understanding and commitment (whether oral and written) made between the Parties with respect to or in connection with any of the matter of things to which this Agreement applies.
16. This Agreement shall be governed by and shall be interpreted in accordance with the laws of India.
17. Any dispute arising in connection with or out of the validity, performance or the interpretation of this Agreement shall be finally settled by the competent jurisdiction in Mumbai.
18. The Receiving Party acknowledges that any breach of the terms and conditions of this Agreement may cause the Disclosing Party irreparable damage for which recovery of money damages would be inadequate. Therefore, the Receiving Party agrees that the Disclosing Party shall be entitled, in addition to any other remedies available to it, to seek injunctive relief and/or other equitable relief to prevent or restrain any breach by the Receiving Party or its employees/officials, or otherwise to protect its rights, under this Agreement.
19. Unless otherwise provided herein, all notices or other communications under or in connection with this Agreement shall be given in writing and may be sent by personal delivery or post or courier or facsimile at the address as specified herein below:

To MDL

Address:

Phone No.:

Fax:

E-mail:

To _____

Address:

Phone No.:

Fax No.:

E-mail:

Any such notice or other communication will be deemed to be effective if sent by personal delivery, when delivered, if sent by post, 4 (four) days after being deposited in the post and if sent by courier, one day after being deposited with the courier, and if sent by facsimile, when sent (on receipt of a confirmation to the correct facsimile number).

IN WITNESS WHEREOF, this Agreement is executed by authorized representatives of both the Parties in two (2) originals.

Signed by the within named

Signed by the within named

MDL

In presence of

In presence of

Note: The above Agreement is to be drawn up by the contractor on non-judicial stamped paper of value Rs.100/-, if it executed in Maharashtra. However, for other places stamp duty is to be levied as per Stamp Act of respective States.

EOI (EXPRESSION OF INTEREST) ACCEPTANCE FORMAT

To,

<EOI issuing Defence Shipyard>

EOI Clause No.	Bidder's Remark	EOI Clause No.	Bidder's Remark
	ACC/DEV		ACC/DEV
1		15	
2		16	
3		17	
4		18	
5		19	
6		20	
7		21	
8		22	
9		23	
10		24	
11		25	
12		26	
13		27	
14			

COMPANY'S NAME & ADDRESS:

SIGNATURE:

DATE:

NAME:

DESIGNATION:

BIDDER'S COMPANY SEAL:

NOTE:

- (a) Bidders should carefully read the Terms & Conditions of the Expression of Interest (EOI) prior to filling up this acceptance format.
- (b) This format should be properly filled, signed and bidder shall upload the scanned copy of the same online.
- (c) Bidder(s) should indicate "ACC" for Accepted, "DEV" for Deviation Taken for each clause number in the above table.
- (d) Bidder(s) to attach Separate Sheet indicating all relevant details such as Number & description of the Clause, Reasons for Deviation and Alternative suggested for any deviations taken by them.
- (e) Clause numbers shown in the above format also includes the sub-clauses under these clauses.

Declaration of Local Content

This declaration must form part of tender & it contains general information and serves as a declaration form for bidder. (Before completing this declaration, bidders must study the General Conditions, Definitions, Govt Directives applicable in respect of Local Content & prescribed tender conditions).

THE BIDDERS SHALL PROVIDE THIS CERTIFICATE FROM STATUTORY AUDITOR OR COST AUDITOR OF THE COMPANY (IN CASE OF COMPANIES) OR FROM A PRACTICING COST ACCOUNTANT OR PRACTICING CHARTED ACCOUNTANT (IN RESPECT OF SUPPLIER OTHER THAN COMPANIES) GIVING THE PERCENTAGE OF LOCAL CONTENT.

IN RESPECT OF BID / TENDER No.

ISSUED BY: (Name of Firm):

NB: The obligation to complete, duly sign and submit this declaration cannot be transferred to an external authorized representative, auditor or any other third party acting on behalf of the bidder.

I, the undersigned, (full names), do hereby declare, in my capacity as of(name of bidder entity), the following:

(a) The facts contained herein are within my own personal knowledge.

(b) I have read and understood the requirement of local content (LC) and same is specified as percentage calculated in accordance with the definition provided at clause 2 of revised Public Procurement (preference to Make in India) Order 2017.

“Local content” as per above order means the amount of value added in India which shall be the total value of items procured (excluding net domestic indirect taxes) minus the value of imported content in the item (including all customs duties) as a proportion of the total value in percent.”

(c) I have satisfied myself that the goods/services/works to be delivered in terms of the above-specified bid comply with the local content requirements as specified in the tender for ‘Class-I Local Supplier’ / ‘Class-II Local Supplier’, and as above.

(d) The local content calculated using the definition given above are as under:

Tender Item Sr No	Description	Local content calculated as above %	Location of local value addition
I	Carbon Steel Pipes		
II	Copper Pipes		

III	Cu-Ni Pipes		
IV	CS Flanges		
V	Mild Steel Flanges		
VI	Gun Metal Flanges		
VII	Deck Bulkhead Fittings		

Attach separate sheet duly signed if space is not sufficient

NB: Local content percentage shall be declared item wise or tender wise strictly as per the terms of the tender.

(e) I accept that the Procurement Authority / Institution / MDL / GRSE / HSL / GSL / Nodal Ministry has the right to request that the local content be verified in terms of the requirements of revised Public Procurement (preference to Make in India) Order 2017 dtd 16.09.2020 and I shall furnish the document / information on demand. Failure on my part to furnish the data will be treated as false declaration as per PPP MII Order 2017. In case of contract being awarded, I undertake to retain the relevant documents for 7 years from date of execution.

(f) I understand that the submission of incorrect data, or data that are not verifiable as described in revised Public Procurement (preference to Make in India) Order 2017, may result in the Procurement Authority / Nodal Ministry / MDL / GRSE / HSL / GSL imposing any or all of the remedies as provided for in Clause 9 of the Revised Public Procurement (preference to Make in India) Order 2017 dated 16.09.2020

SIGNATURE: _____

DATE: _____

Seal / Stamp of Bidder

Bid Security Declaration Format
(On Bidders Letterhead)

Date: _____ EoI No: _____

To
 Mazagon Dock Shipbuilders Limited / Defence Public Sector Shipyards
 Dockyard Road,
 Mumbai : 400 010

I/We the undersigned declare that:

- 1) I/We understand that, according to your conditions, bids must be supported by a Bid Securing Declaration.
- 2) I/We accept that I/We may be disqualified / debarred from bidding against Mazagon Dock Shipbuilders Limited EoIs / tenders for a period of one year from the date of notification if I/We are in a breach of any obligation under the bid conditions, because I/We
 - a) have withdrawn/modified/amended, impairs or derogates from the tender, my/our bid during the period of bid validity specified in the form of Bid; or
 - b) having been notified of the acceptance of our Bid by the purchaser during the period of bid validity fail or refuse to execute the contract.
- 3) I/We understand this Bid Securing Declaration shall cease to be valid on the Thirty First day from following,
 - a) if I am/we are not the successful Bidder, the receipt of your notification of the name of the successful Bidder; or
 - b) the expiration of the validity of my/our Bid or any extension thereof.

Signed: _____ (insert signature of person whose name and capacity are shown)
 In the capacity of _____ (insert legal capacity of person signing the Bid Security Declaration)

Name: _____ (insert complete name of person signing the Bid Security Declaration)
 Duly authorised to sign the bid for and on behalf of _____ (insert complete name of Bidder)

Dated on _____ day of _____ (insert date of signing)
 Corporate Seal (where appropriate)

(Note: in case of a Joint Venture, the Bid Security Declaration must be in the name of all partners to the Joint Venture that submits the bid)

STANDARD DRAWING OF DPSU SHIPYARDS

**DECK / BULKHEAD FITTING
FOR CARBON STEEL PIPES**

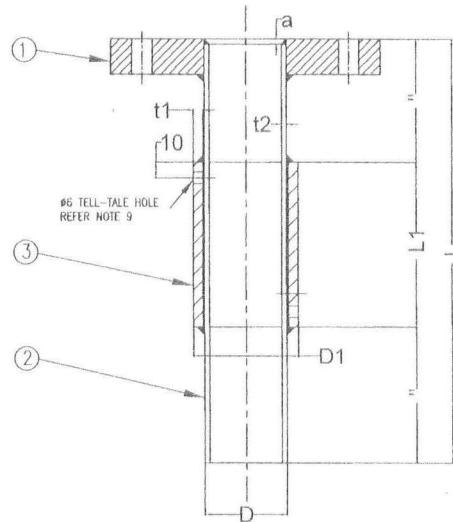

DIMENSIONAL DATA													
NB	PIPE OD (mm) 'D'	PIPE THK (mm) 't2'	PIPE SCHEDULE	PIPE LENGTH (mm) 'L'	SLEEVE OD (mm) 'D1'	SLEEVE THK (mm) 't1'	SLEEVE ID (mm)	SLEEVE LENGTH (mm) 'L1'	FLANGE SIZE	Gap for welding 'a'	SAP NO. (GALVANISED)	SAP NO. (NON-GALVANISED)	REMARKS
10	17.1	3.20	Sch. 80	300	27.1	4	19.1	150	10 NB	6	----	----	----
15	21.3	3.73	Sch. 80	300	31.3	4	23.3	150	15 NB	6	----	----	----
20	26.7	3.91	Sch. 80	300	36.7	4	28.7	150	20 NB	6	----	----	----
25	33.4	4.55	Sch. 80	300	43.4	4	35.4	150	25 NB	6	----	----	----
32	42.2	4.85	Sch. 80	300	52.2	4	44.2	150	32 NB	6	----	----	----
40	48.3	5.08	Sch. 80	300	58.3	4	50.3	150	40 NB	7	----	----	----
50	60.3	5.54	Sch. 80	300	74.3	6	62.3	150	50 NB	7	----	----	----
65	73.0	7.01	Sch. 80	300	87.0	6	75.0	150	65 NB	8	----	----	----
80	88.9	7.62	Sch. 80	300	110.9	10	90.9	150	80 NB	8	----	----	----
100	114.3	8.56	Sch. 80	300	136.3	10	116.3	150	100 NB	9	----	----	----
125	141.3	9.53	Sch. 80	300	163.3	10	143.3	150	125 NB	9	----	----	----
150	168.3	10.97	Sch. 80	300	190.3	10	170.3	150	150 NB	9	----	----	----
200	219.1	12.70	Sch. XS	300	247.1	13	221.1	150	200 NB	10	----	----	----
250	273.0	12.70	Sch. XS	350	301.0	13	275.0	175	250 NB	10	----	----	----
300	323.8	12.70	Sch. XS	350	251.8	13	325.8	175	300 NB	10	----	----	----

NOTES:

- 1) PERMANENT MARKING TO BE DONE ON CIRCUMFERENCE OF FLANGE AND ON SLEEVE BY MEANS OF INTEGRAL CASTING/FORGING OR STAMPING (HARD PUNCH) AS PERMANENT IDENTIFICATION.
- 2) ALL RAW MATERIAL USED SHALL BE FRESH / NEW I.E. RECYCLING OF USED MATERIAL IS NOT ACCEPTABLE.
- 3) WELDING SHALL BE CARRIED OUT AS PER ASME Sec. IX - USING APPROVED WPS & PQR.
- 4) ALL FITTINGS ARE TO BE HYDRO TESTED AFTER FABRICATION AT PRESSURE OF 20 BAR WITH FRESH WATER.
- 5) ALL FITTINGS SHALL BE CLEAN, SMOOTH & FREE FROM DEFECTS GREATER THAN 0.5 mm. IN DEPTH, IRREGULARITIES SCALES OR DEPOSITS & SHALL BE FREE FROM DAMAGING FILMS IN THE BORE.
- 6) UNSPECIFIED TOLERANCES CONFIRM TO IS 2102 & ASME B 16.9.
- 7) GALVANISED FITTINGS SHALL BE GALVANISED (HOT DIP GALVANISED) AS PER BS 729.
- 8) NON-GALVANISED FITTINGS SHALL BE EXTERNALLY COATED WITH PRIMER.
- 9) TWO (02) TELL-TALE HOLES OF 6mm DIA TO BE PROVIDED. EACH HOLE ON EITHER END OF THE SLEEVE WITH 180 DEG APART.
- 10) EACH FITTING SHALL BE DRAINED, CLEANED & SUITABLY PROTECTED FOR DISPATCH IN SUCH A WAY SO AS TO PREVENT CONTAMINATION DURING TRANSPORTATION & STORAGE. EACH FITTING IS TO BE PACKED SEPARATELY. BOTH ENDS OF FITTINGS SHALL BE PROTECTED WITH PLASTIC, WOOD OR METAL COVER. THE MACHINED SURFACE OF FITTINGS ARE TO BE SUITABLY PROTECTED AGAINST MECHANICAL DAMAGE DURING SHIPMENT & STORAGE. THE RUST/CORROSION PREVENTIVE USED SHALL BE REMOVABLE WITH A PETROLEUM SOLVENT OR THE SAME SHALL NOT BE HARMFUL TO WELDING.
- 11) CERTIFICATE OF COMPLIANCE (DIMENSIONAL, MATERIAL & HYDRO TESTING) STATING THAT FITTINGS HAS BEEN MADE IN ACCORDANCE WITH ALL REQUIREMENTS AS PER THE SPECIFICATIONS SHALL BE SUPPLIED ALONG WITH SUPPLIES.
- 12) WEIGHT CERTIFICATE OF ALL FITTINGS TO BE SUBMITTED BY VENDOR ALONG WITH SUPPLIES.

SR.NO.	ITEM DESCRIPTION	MATERIAL SPECIFICATION	QTY.
1	FLANGE (PN10)	Flange, PN 10, Material - Mild Steel, IS 2062, E250 Br. & Dimensions as per BS EN 1092, Part 1, PN 10. Slip-on flange, Type 01 flange with Type A flat face with concentric serrations on external face.	01
2	PIPE	Carbon Steel, As per ASTM A 106 Gr. B & ANSI B 36.10. Seamless. All dimensional tolerances shall be as per ANSI B 36.10.	01 (Length as per table)
3	DK/BHD. SLEEVE	To be made by rolling of plate (maximum of two weld seems acceptable) Mild Steel, IS 2062, E250 Br.	01 (Length as per table)

0	FIRST ISSUE		10.02.2026
REV	DESCRIPTION		DATE
	TITLE	MDL	GRSE
	DECK / BULKHEAD FITTING STRAIGHT TYPE (FOR CARBON STEEL PIPES)	SANTOSH S	TANMOY M
		GSL	HSL
		RAYSON B	RAJA KRISHNA
		DESG.	DGM
		SM	SM
		DATE	
		DOCUMENT / DRAWING NUMBER	
		DPSU-STD-DBH-STA-CST-PN010	
		SHEET 01 OF 01	NOT TO SCALE

STANDARD DRAWING OF DPSU SHIPYARDS

DECK / BULKHEAD FITTING (BUSH TYPE) FOR 90/10 CUNI PIPES & COPPER PIPES

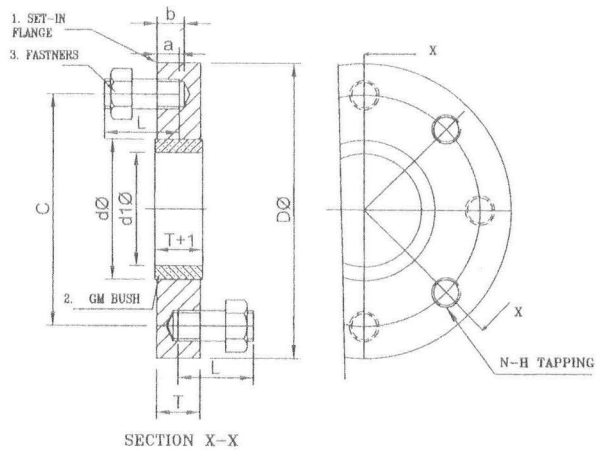

DIMENSIONAL TABLE (All dimensions are in mm)

PIPE	SET IN FLANGE					STUD BOLT W/ NUTS				G.M BUSH		ITEM CODE
	NB	O.D	D	C	T	b	N	H	L	a	g	
10	16	90	60	24	17	2x4	M12	45	12	23	14
15	20	95	65	24	17	2x4	M12	45	12	28	18
20	25	105	75	24	17	2x4	M12	55	12	33	22
25	30	115	85	24	17	2x4	M12	55	12	38	27
32	38	140	100	29	21	2x4	M16	60	16	47	34
40	44.5	150	110	29	21	2x4	M16	65	16	53	40
50	57	165	125	29	21	2x4	M16	65	16	68	54
65	76.1	185	145	29	21	2x4	M16	65	16	87	72
80	88.9	200	160	29	21	2x8	M16	65	16	102	84
100	100	220	180	29	21	2x8	M16	65	16	123	103
125	133	250	210	29	21	2x8	M16	65	16	148	128
150	159	285	240	35	26	2x8	M20	80	20	175	154
175	193.7	315	270	35	26	2x8	M20	60	20	210	187
200	219.1	340	295	35	26	2x8	M20	63	20	236	213
250	267	395	350	35	26	2x12	M20	85	20	284	261
300	323.8	445	400	35	26	2x12	M20	85	20	344	316
350	388	505	460	35	26	2x16	M20	85	20	388	362
400	419	565	515	39	29	2x16	M24	100	24	441	412
500	508	676	620	44	29	2x20	M24	110	24	533	500

NOTES:

- 1) PERMANENT MARKING TO BE DONE ON CIRCUMFERENCE OF FLANGE BY MEANS OF INTEGRAL CASTING/FORGING OR STAMPING (HARD PUNCH) AS PERMANENT IDENTIFICATION.
- 2) ALL RAW MATERIAL USED SHALL BE FRESH / NEW i.e. RECYCLING OF USED MATERIAL IS NOT ACCEPTABLE.
- 3) WELDING SHALL BE CARRIED OUT AS PER ASME Sec. IX - USING APPROVED WPS & PQR.
- 4) ALL FITTINGS ARE TO BE HYDRO TESTED AFTER FABRICATION AT PRESSURE OF 20 BAR WITH FRESH WATER.
- 5) ALL FITTINGS SHALL BE CLEAN, SMOOTH & FREE FROM DEFECTS GREATER THAN 0.5 mm. IN DEPTH, IRREGULARITIES SCALES OR DEPOSITS & SHALL BE FREE FROM DAMAGING FILMS IN THE BORE.
- 6) UNSPECIFIED TOLERANCES CONFIRM TO IS 2102 & ASME B 16.9.
- 7) FITTINGS TO BE SUPPLIED AS A SET (SET-IN FLANGE, BUSH(FITTED), STUDS WITH NUTS).
- 8) SET-IN FLANGE (PART NO. 1) SHALL BE GALVANIZED (HOT DIP GALVANISED) AS PER BS 729.
- 9) GM BUSH TO BE PRESS-FITTED (INTERFERENCE FIT) IN TO MS SET-IN FLANGE AS SHOWN.
- 10) HOLES SHALL BE TAPPED EQUALLY SPACED ON EITHER SIDE OF THE SET IN FLANGE.
- 11) THICKNESS OF NUT SHOULD BE 0.8D STD.
- 12) EACH FITTING SHALL BE DRAINED, CLEANED & SUITABLY PROTECTED FOR DISPATCH IN SUCH A WAY SO AS TO PREVENT CONTAMINATION DURING TRANSPORTATION & STORAGE. EACH FITTING IS TO BE PACKED SEPARATELY. BOTH ENDS OF FITTINGS SHALL BE PROTECTED WITH PLASTIC, WOOD OR METAL COVER. THE MACHINED SURFACE OF FITTINGS ARE TO BE SUITABLY PROTECTED AGAINST MECHANICAL DAMAGE DURING SHIPMENT & STORAGE. THE RUST/CORROSION PREVENTIVE USED SHALL BE REMOVABLE WITH A PETROLEUM SOLVENT OR THE SAME SHALL NOT BE HARMFUL TO WELDING.
- 13) CERTIFICATE OF COMPLIANCE (DIMENSIONAL, MATERIAL & HYDRO TESTING) STATING THAT FITTINGS HAS BEEN MADE IN ACCORDANCE WITH ALL REQUIREMENTS AS PER THE SPECIFICATIONS SHALL BE SUPPLIED ALONG WITH SUPPLIES.
- 14) WEIGHT CERTIFICATE OF ALL FITTINGS TO BE SUBMITTED BY VENDOR ALONG WITH SUPPLIES.

SR.NO.	ITEM DESCRIPTION	MATERIAL SPECIFICATION	QTY.
1	SET-IN FLANGE (PN10)	Mild Steel as per IS 2062. Hot dip galvanised	01
2	GM BUSH	Gun Metal to BS 1400 LG4C	01
3	FASTENERS	Set of Studs with nuts, Material - SS 316 with Teflon Coating	As per table

0	FIRST ISSUE							10.02.2026	
REV		DESCRIPTION						DATE	
TITLE DECK / BULKHEAD FITTING BUSH TYPE (FOR 90/10 CUNI PIPES & COPPER PIPES)		MDL	GRSE	GSL	HSL	DOCUMENT / DRAWING NUMBER		REV	
		NAME/SIGN	SANTOSH S	TANMOY M	RAYSON B	RAJA KRISHNA	DPSU-STD-DBH-BUS-CNI-PN010		0
		DESC.	DGM	SM	DGM	SM	[] [] [] [] [] [] [] [] [] []		[]
		DATE	15/2	15/2	15/2	15/2	SHEET 01 OF 01		NOT TO SCALE

