



Mazagon Dock Shipbuilders Limited, Mumbai

Additional Tender Terms and Conditions

Tender No. GEM/2026/B/7695386

Eligibility to bid: Class-I & II Local Supplier Only (Gaurd Rail Stanchions)

Type of tender: Open Tender

1. **DESCRIPTION & SCOPE OF SUPPLY / WORK:**

SUPPLY OF MATERIAL OF GUARD RAIL STANCHIONS ARRANGEMENT ON WEATHER DECKS AS PER DWG.NO: 1401-01 REV-04 FOR 01 TS (Y-16101) (DWG ENCLOSED)

2. **EARNEST MONEY DEPOSIT (EMD) / BID SECURITY: INR 75,000/-**

(a) EMD shall be obtained by way of NEFT/ Demand Draft / Pay order / Bank Guarantee / Insurance Security Bond / e-Bank Guarantee in favour of Mazagon Dock Shipbuilders Limited, Mumbai from the list of Banks approved by SBI / Canara Bank published on MDL website. Crossed DD / Pay Order issued by Co-operative banks however may be considered to be accepted and the bid would be considered accordingly.

In case of foreign bidders, authorized Indian agent of the overseas bidders can submit EMD in the form of bank draft in Indian Rupees. Similarly authorized Indian Agent can submit BG from bank as per list of banks approved by SBI / Canara Bank as bank of international repute published on MDL website on behalf of foreign bank. Bidders are encouraged to advice their banker to send EMD directly to commercial department or through SWIFT (MDL account mentioned below) to dispense with additional step of verification of authenticity of signatories. In case of EMD transmitted through SWIFT, it shall be the responsibility of the bidder that he directs the receiving banker to forward the message duly authenticated to the concerned commercial executive mentioned in the tender.

Details of MDL Bank Account:

Beneficiary Name: Mazagon Dock Shipbuilders Limited

Current A/c. No.: 10005255246

IFSC Code: SBIN0009054

Bank Name: STATE BANK OF INDIA

Bank Branch Address: "Mazagaon Dock Branch, Opp. Nirman Bhavan, Mazagaon, Mumbai-400010."

Commercial executive on receipt of Demand Draft / Pay Order from indigenous bidders shall forward the same immediately to the Treasury Section of Finance Dept. In case of foreign bidders, EMD shall be obtained by way of SWIFT / Bank Guarantee from bank of international repute or other banks. The Bank Guarantee shall be kept valid till validity period of the offer. The original of the scanned copy of EMD (BG) should reach HOS (C)/ Dealing Executive within seven days of the tender closing date.

Bids / Offers without EMD/Bid Bond along with Part-I bid will not be considered. EMD of unsuccessful bidders will be returned after finalization of the tender and shall be interest free.



Mazagon Dock Shipbuilders Limited, Mumbai

Additional Tender Terms and Conditions

Tender No. GEM/2026/B/7695386

Eligibility to bid: Class-I & II Local Supplier Only (Gaurd Rail Stanchions)

Type of tender: Open Tender

Firm should submit the original EMD in closed envelope (Sealed), Super scribed as EMD/BID Bond for Bid No....., due date, time, and addressed to, HOD (EY-Commercial Dept.), Alcock Yard, MAZAGON DOCK SHIPBUILDERS LIMITED, Dock Yard Road, Mumbai, 400010, INDIA, and should be Submitted at below address within 7 working days from the Bid closing date.

DGM/PE(C-CGP),
5th Floor,
New Service Block,
North Yard,
Mazagon Dock Shipbuilders Limited,
Dock Yard Road,
Mumbai-400010, Maharashtra,

The scanned image of EMD shall be uploaded at Part-I tender stage.

Timely submission of the original EMD is the responsibility of the bidders and no reasons / excuses in this regard will be entertained by MDL. Original EMD reached after 7 working days from tender closing date & time will render the e-bid (submitted by bidder) liable for rejection.

(b) Exemption from submission of EMD / BID Bond:

Following bidders shall be exempted from submission of EMD/Bid Bond:

- i) State & Central Government of India Departments & Public Sector Undertakings.
- ii) Firms registered with MDL against the service group 1402340 (Semi finish Material). To qualify for EMD exemption, firms should necessarily submit valid copy of the Registration Certificate issued by MDL, for the items for which the offer is being submitted. Firms in the process of obtaining MDL registration will not be considered for EMD exemption.
- iii) Micro and Small Enterprises who are manufacturer or Service Provider and give specific confirmation to this effect at the time of bid submission and whose credentials are validated online through Udyam Registration (as validated by Government from time to time) and through uploaded supporting documents.
- iv) Firms registered with NSIC under its "Single Point Registration Scheme". (Exemption will apply only to items/services for which they are registered. To qualify for EMD exemption, firms should necessarily submit valid copy of the Registration Certificate along with the list of items / services for which they are registered, as issued by NSIC, in Part-I offer / bid. Firms in the process of obtaining NSIC registration will not be considered for EMD exemption.
- v) Start-ups as recognized by Department of Industrial Policy and Promotion (DIPP).
- vi) The recognized institutes such as VJTI/IIT.
- vii) Common/Deemed DPSU registered vendors qualify for EMD exemption. Such firms shall submit valid copy of the registration certificate issued by DPSUs (other than MDL) for the items / services for which the offer is being submitted in Part-I



Mazagon Dock Shipbuilders Limited, Mumbai

Additional Tender Terms and Conditions

Tender No. GEM/2026/B/7695386

Eligibility to bid: Class-I & II Local Supplier Only (Gaurd Rail Stanchions)

Type of tender: Open Tender

offer/bid. Firms in process of obtaining registration in other DPSUs will not be considered for EMD exemption.

viii) Green Channel Status vendors qualify for EMD exemption. Such firms shall submit valid copy of the green channel certificate issued by MoD for the items for which the offer is being submitted

(c) Forfeiture of EMD:

EMD shall be forfeited in the following cases:

- i) Bidder withdraws, amends, impairs or derogates from the tender, agreed conditions of TNC /PNC in any respect within the period of validity of his offer.
- ii) Non-acceptance of order.

3. Commercial Qualification Criteria for Goods:

(i) The average annual financial turnover of 'The bidder' during the last three years, ending 31st March of the previous financial year excluding the calendar year of tendering should be at INR 11.25 Lakhs as per the annual report (audited balance sheet as applicable and profit and loss account) of the relevant period, duly authenticated by a Chartered Accountant/Cost Account.

(ii) Bidders Shop and establishment registration certificate or registration certificate from registrar of firms or certificate of incorporation from Registrar of Companies (Not required for permanent registered vendors with MDL, in such case MDL Permanent Registration certificate attach.)

4. VALIDITY PERIOD OF OFFER:

- i. Bids / Offers shall have a validity period of 180 days from the Bid closing date. A bid valid for a shorter period will be liable for rejection.
- ii. In exceptional circumstances, before the expiry of the original time limit, MDL may request the bidders to extend the validity period for a specified additional period. The request and the bidders' responses shall be made in writing or electronically. A bidder may agree to or reject the request. A bidder who has agreed to MDL's request for extension of bid validity, in no case, he shall be permitted to modify his bid.

5. DELIVERY PERIOD/CONTRACT PERIOD:

- i. PO + 02 Months from Placement of Order inclusive of QAP approval and site visit for measurements prior to fabrication.

6. SUBMISSION OF OFFER IN TWO BID SYSTEM: Offer must be submitted in two parts as follows:

- (a) **Part I (Techno Commercial Bid):** The bidder shall ensure that following are essentially submitted in the Part-I bid as applicable:
 - (i) Technical & Commercial offer.
 - (ii) Pre-qualification documents.



Mazagon Dock Shipbuilders Limited, Mumbai

Additional Tender Terms and Conditions

Tender No. GEM/2026/B/7695386

Eligibility to bid: Class-I & II Local Supplier Only (Gaurd Rail Stanchions)

Type of tender: Open Tender

- (iii) Valid MSME Udyam Certificate, MDL Registration Certificate & ISO Accreditation Certificate (If applicable).
- (iv) Taxes and duties certificate for which they are registered.
- (v) Acceptance of Tender terms & GTAC
- (vi) Declaration of Local Content, preference for MSE Order 2012 / PPP Order 2017 for purchase preference.
- (vii) Blank rate sheet indicating quoted/not quoted against each line item, tax percentage, type of taxes and HSN code.
- (viii) Bank details for payment by RTGS/NEFT in the format enclosed.
- (ix) Bidder contact details as per attached annexure" Contact Details of the bidder.
- (x) Undertaking for product support as per TSP if applicable.
- (xi) Additional documents as applicable to this tender.
- (xii) GST certificate, PAN card and cancelled cheque.
- (xiii) Valid MSE Certificate with proof of manufacturing i.e OEM certification on firms Letterhead, in case applying for MSME PPP.
- (xiv) Local Content Declaration as attached with this document clearly opting for checkboxes for MSE and/or MII as applied at GeM by the firm.

Note: In any case, prices are not to be mentioned in Part-I bid.

- (b) **Part-II (Price Bid):** Prices for each of the listed items has to be uploaded strictly in the prescribed format provided in the GeM portal.

7. BID REJECTION CRITERIA:

A. Categorical Rejection Criteria

The following conditions / deviations are non-negotiable and therefore any bid falling under these conditions / deviations will be summarily rejected. Bidders to note that they shall not be provided any opportunity to rectify these conditions / deviations post bid opening:

- a. Bids received after tender closing date and time.
- b. Bids received other than through e-portal (in case of e-tender).
- c. Bids received without EMD (other than those who are exempted from payment of EMD).
- d. Bidders who are debarred under PPP MII order 2017, GeM, CPPP including Tender holiday issued by MDL.

B. Liable rejection criteria: Non-compliance/non-acceptance to any of the terms and conditions of the tender other than following shall render the bid liable for rejection;

- (i) Clause mentioned under loading criteria or terms not acceptable to firm.



Mazagon Dock Shipbuilders Limited, Mumbai

Additional Tender Terms and Conditions

Tender No. GEM/2026/B/7695386

Eligibility to bid: Class-I & II Local Supplier Only (Gaurd Rail Stanchions)

Type of tender: Open Tender

Bidder to note that the shortfall information/documents shall be sought only in case of historical documents which pre-existed at the time of the tender opening i.e. submitted along with original bid and which have not undergone change since then.

8. PERFORMANCE SECURITY (PS):

- (a) Performance Security for an amount equal to 5% of contract value payable in Indian Rupees shall be submitted as per GeM terms.
- (b) Performance Security is to be furnished as per GeM after notification of the award of contract and it should remain valid for a period of 60 (sixty) days beyond the date of completion of all contractual obligations of the supplier, including warranty obligations.
- (c) **Structural Financial Messaging System Bank Guarantee (SFMS BG) in lieu of Bank Guarantee**

In case the Indigenous Bidders intends to submit Bank Guarantee towards Performance security/EMD/Advance payment/Free Issue Material etc, the Bank Guarantee should be e-Bank Guarantee or Structural Financial Messaging System Bank Guarantee (SFMS BG).

(i)Mandatory Requirement: Whenever a bidder submits SFMS BG, the bidder will mandatorily be required to submit letter from issuing bank that it is unable to issue NeSL(National e-Governance Service Ltd) based e-BG as on date. Such letter should accompany the SFMS BG.

(ii)IFSC Code: While submitting the Structural Financial Messaging System Bank Guarantee (SFMS BG). IFSC: ICIC0000393 shall be used.

(iii)Authenticity of SFMS BG: Bidder shall get SFMS BG issued from SFMS enabled Bank as allowed by MDL in tender conditions. Bank shall issue the Bank Guarantee through SFMS system and send SFMS message to MDL's Bank confirming the authenticity of Bank Guarantee. Bidder will be required to submit SFMS BG along with SFMS delivery report/message copy which has been transmitted to MDL's bank by BG issuing bank through SFMS system.

(iv)Stamp Paper/Frinking Receipt: The SFMS BG will have to be given on non-judicial stamp paper/ with frinking receipt e-stamping as per stamp duty applicable at the place from where the bid has emanated. The nonjudicial stamp paper/ frinking receipt e-stamping should be either in the name of the issuing bank or the bidder.

(v) Receipt of SFMS BG: The Original SFMS BG in physical form, (along with SFMS delivery Report/Message copy which has been transmitted by issuing Bank through SFMS system to beneficiary's i.e., MDL Bank) should reach to MDL designated office on or before due date.



Mazagon Dock Shipbuilders Limited, Mumbai

Additional Tender Terms and Conditions

Tender No. GEM/2026/B/7695386

Eligibility to bid: Class-I & II Local Supplier Only (Gaurd Rail Stanchions)

Type of tender: Open Tender

(vi)Mandatory Requisite Information: SFMS BG will not be acceptable unless details of the same is transmitted to the MDVs Bank through SFMS platform. Its bidder's responsibility to ensure that BG issuing bank send the BG advice correctly in the lorm of message format 760 COV vis SFMS (Structured Financial Messaging System) as provided by RBI while capturing all requisite fields including Beneficiary Account Name, Bank Name. Bank Account Number. IFSC Code etc.

(vii)Non-Acceptance of BG: In case of any error by the Bidder/contractor or BG issuing Bank while capturing the requisite field details / format or non-receipt of confirmation of BG through SFMS 760COV message format, the bidder/contractor shall be responsible for non-acceptance of the SFMS Bank Guarantee.

(viii)Amendment in BG: For any amendment of SFMS BG, message 767COV through SFMS should be used.

9. **WARRANTY/GUARANTEE:**

- (a) The equipment / item along with associated auxiliaries/components supplied shall be warranted / guaranteed for satisfactory Performance for the period of (Twelve month) **12 MONTHS FROM DATE OF RECEIPT & ACCEPTANCE OF MATERIAL.**
- (b) The supplier cannot absolve their responsibility for warranty of material even though it is inspected by & approved by the inspection authorities.
- (c) If the defects are not remedied within a reasonable/stipulated time, MDL may proceed to rectify the defects at the supplier's risk & cost, but without prejudice to MDL's rights under the contract.
- (d) During the period of warranty / guarantee if any defect noticed in the equipment / item supplied, the supplier/ contractor will have to rectify such defects immediately at no extra cost to MDL.

10. **PRICING:**

- (a) Prices of all items/services shall be quoted for delivery of the items/services to the following destination including charges towards transportation, insurance, and other local costs incidental to the delivery of the Goods/Services.
- (b) Delivery Address: -
BOND STORE, ANIK CHEMBUR.
- (c) The prices quoted shall remain firm and fixed during the currency of the order / contract unless agreed otherwise by MDL.
- (d) **Price Variation Clause: (For Goods & Services):** Not Applicable

11. **TAXES & DUTIES:**

- (a) Bidders must clearly mention the applicable Taxes & Duties in the rate sheet enclosed in the tender. The item-wise rates (i.e. Basic + Packing, Forwarding, Freight & Insurance) quoted in the Rate sheet should exclude Taxes, Cess & Duties. Bidder should indicate GST rates as applicable separately under each of



Mazagon Dock Shipbuilders Limited, Mumbai

Additional Tender Terms and Conditions

Tender No. GEM/2026/B/7695386

Eligibility to bid: Class-I & II Local Supplier Only (Gaurd Rail Stanchions)

Type of tender: Open Tender

the head in the same rate sheet, which will be paid extra based on tax invoice to the extent applicable.

- (b) Supplier / contractor will not be entitled to any increase in rate of taxes occurring during the period of extended delivery completion schedule if there is delay in supplies / completion attributed to him. However, if there is a decrease in taxes, the same must be passed on to MDL.
- (c) Income tax applicable on cost of services rendered in India in relation to the contract, shall be payable by bidders.
- (d) TDS (GST) shall be carried out as per the existing Laws and Acts.
- (e) **Goods and Services Tax (GST):**
- (i) The prevailing rate of GST is to be indicated in your blank rate sheet in Part-I.
- (ii) For MDL's GST number, please visit our website. MDL's GST Number is **27AAACM8029J1ZA**.
- (iii) Bidder shall mention MDL GSTIN while invoicing and avoid any data entry error on GST portal.
- (iv) Bidders shall mandatorily mention their GST number in their offer.
- (v) Bidders shall mention the HSN (Harmonised System of Nomenclature) code for the quoted items and services in their offer. These codes must be in accordance with GST law and responsibility of specifying correct HSN codes for goods &/or services is that on the bidder. MDL shall not be responsible for any error in HSN no. specified by vendor. However, if any penalty is levied on MDL or any loss of ITC to MDL occurs or any delay in availing ITC by MDL occurs due to such error, vendor shall reimburse such loss after intimation by MDL or the amount shall be recovered from the SD or any outstanding payments to the vendor.
- (vi) Bidder must mention HSN numbers in invoices as reflected in the order. These codes must be in accordance with GST law.
- (vii) If bidder is registered under GST, bidder should note that successful bidder shall ensure timely submission of invoice and file all applicable returns under GST Law in the stipulated time & any losses of ITC to MDL arising due to delay in submission of invoice or delay in filing will be recovered from their invoice wherever MDL is eligible to avail tax credit. Any default towards payments of tax and / or uploading of monthly returns by supplier / contractor, MDL retains right to withhold payments towards tax portion until the same is corrected & complied by the supplier/ contractor with the requirement of GST along with satisfactory evidence.
- (viii) Original invoice to be submitted to Bill Receipt Centre at MDL gate and a copy of the invoice to be submitted to the respective stores.
- (ix) If the GST rating of supplier / contractor on GST portal/ Govt. website is found to be negative/ blacklisted, the MDL reserves the right to reject the offer of such bidders. Similarly, on post placement of the contract/order, MDL shall reimburse GST to the vendor only after he makes the payment of GST and fulfils all requirements as per GST law for successful GST along with penalties/interest, if any, incurred by MDL.
- (x) In case, MDL is unable to avail ITC, supplier/ contractor at their own cost shall rectify the shortcoming in the returns to be filed immediately



Mazagon Dock Shipbuilders Limited, Mumbai

Additional Tender Terms and Conditions

Tender No. GEM/2026/B/7695386

Eligibility to bid: Class-I & II Local Supplier Only (Gaurd Rail Stanchions)

Type of tender: Open Tender

thereafter. Further, if the ITC is delayed / denied to MDL/ reversed subsequently as per GST laws due to non/ delayed receipt of goods and/ or services and/ or tax invoices or expiry of timelines prescribed in GST Laws for availing ITC, nonpayment of taxes or non-filing of returns or any other reason not attributable to MDL, such amount shall be recoverable from supplier / contractor along with interest and penalty as levied on MDL under GST Law for the number of days the ITC was delayed. This amount shall be recovered from the SD or any outstanding payments. If the short coming is not rectified by supplier / contractor and MDL ends up in reversal of credits and / or payments, supplier / contractor is fully liable for making good all the loss incurred by MDL as a result of default.

(xi) If bidder is registered under GST, Suppliers shall be responsible for the financial and non-financial consequences in case of non-compliance of GST provisions/requirements/timelines on their part.

(f) **Custom Duty** will not be reimbursed to the vendor.

12. PAYMENT TERMS:

(a) Advance payment is not applicable for this tender

(b) On receipt of Invoice, 100 % of Payment shall be made within 15 days from generation of Consignee Report and acceptance certificate (CRAC) of material and submission and confirmation of PSBG and as reduced by any deductibles and / or the amount leviable towards liquidated damages, if any plus 100% taxes, duties etc. as applicable.

(c) Part Payment: MDL does not consider part supply and part payment in general. However, in exceptional circumstances, Lot/part supply will be considered as discussed in TNC and in case part/lot supply is acceptable to MDL, part payment may be considered. If any deliveries are made in parts/lots, then all the invoices received in that month for the supplies would be clubbed and processed.

13. PAYMENT MODE & REQUISITE DOCUMENTS FOR PAYMENT:

(a) All the payments to indigenous bidders due shall be made through Real Time Gross Settlement (RTGS) / National Electronic Fund Transfer (NEFT) by MDL.

(b) Documents for Payments for Indian Bidders (Goods):

(i) Suppliers invoice/Delivery challan.

(ii) PO copy with amendments if any

(iii) Confirmation of receipt and verification of Bank Guarantee for Performance security as the case may be.

(iv) Guarantee/Warrantee Certificate

(v) Inspection release note (If applicable)

(vi) Actual local content declaration.

Note: Invoices should be submitted at "Receipt Section" adjacent to the ARS Punching Section, South Yard MDL.

(c) **E-Invoice:** -



Mazagon Dock Shipbuilders Limited, Mumbai

Additional Tender Terms and Conditions

Tender No. GEM/2026/B/7695386

Eligibility to bid: Class-I & II Local Supplier Only (Gaurd Rail Stanchions)

Type of tender: Open Tender

The vendors, whose aggregate turnover in any preceding financial year from FY 2017-18 onwards, exceeds INR 5 crore as per GST Act or as applicable from time to time, will have to issue an e-Invoice with a Quick Response (QR) code and Invoice Registration No.(IRN), It is important to note that MDL will not be entitled for Input Tax Credit (ITC)/GST on a vendor Invoice which is not compliant with the above e-Invoice notification. Wherever GST is applicable, payment will be released against e-Invoice, or Invoice accompanied with vendor's self-declaration that

"we do not fall under the category of registered persons notified under Rule 48(4) of the Central GST Rules, 2017 and we are not required to comply with e-Invoicing provisions under GST Act, as our aggregate turnover in any preceding financial year from 2017-18 onwards has not exceeded INR 5 crore as per GST Act".

(d) **Alternate MSME vendor payment through TReDS:**

- i) In order to address the financial needs of MSME firms, GoI has introduced a platform for facilitating the financing of trade receivables of MSMEs from buyers, through multiple financiers which is termed as Trade Receivables Discounting System (TReDS). At TReDS, auctioning of invoices at competitive & transparent environment is done by financiers based on Buyer's credit profile.
- ii) MDL is registered on the "Invoicemart" TReDS platform and M1xchange of M/s Mynd Solutions Pvt. Ltd.
- iii) MSME bidders desirous to receive payments through TReDS platform may avail the facility if they are already registered on
 - a) "Invoicemart" TReDS platform or by registering on it.
Contact details at "Invoicemart" TReDS platform are as below:
022 6235 7373 and a new mail id service@invoicemart.com.
 - b) "M1xchange" TReDS platform or by registering on it.
Contact details at "M1xchange" TReDS platform are as below:
+91 9920455374 Ms Ashwathi Jayandran email id:
ashwathi.jayandran@m1xchange.com
+91 8839915724 Ms Priyanka Shah email id
prinyaka.shah@m1xchange.com

14. **EXCHANGE RATE VARIATION (ERV):** Not applicable.

15. **MODE OF DISPATCH:** Road/Rail/Air/Sea.

16. **CONSIGNEE:**

- (a) Material scheduled for delivery are to be delivered at MDL (BOND STORE, ANIK CHEMBUR.)
Note:-In order to avoid inconvenience during the delivery of material, it is advisable for supplier to depute their representative in their own interest to coordinate the activities between the transporter, and MDL stores.
- (b) Following document should be submitted along with material:



Mazagon Dock Shipbuilders Limited, Mumbai

Additional Tender Terms and Conditions

Tender No. GEM/2026/B/7695386

Eligibility to bid: Class-I & II Local Supplier Only (Gaurd Rail Stanchions)

Type of tender: Open Tender

- PO copy & subsequent amendments issued to it, if any.
 - Inspection Release Note (IRN) issued by nominated inspection officer, If applicable.
 - Delivery Challans clearly indicating MDL Purchase Order No, Inspection Note Details and Packing List co-relating the items in the inspection report.
 - Copy of Warranty Certificate, Preservation Certificate etc.
 - Technical documentation, if applicable.
 - E-Way bill (if applicable) details are to be submitted during the delivery of the items.
- (c) Unloading of the equipment/ items will be arranged by MDL. In case of delivery of Large/ Bulky/ Heavy consignments, supplier is required to give 2 to 4 day's advance intimation to MDL clearly indicating approx. dimensions and weight of consignments for arranging fork lift/crane for unloading.
- (d) Please note that our stores will accept materials only between 08.30 A.M to 11.30 A.M and 12 Noon to 03.30 P.M., on all working days except MDL holidays. MDL do not accept materials on Saturdays & Sundays. Materials brought to MDL after 15.30 Hrs. will not be accepted. In this connection, for any clarification, you may contact our Officer-in-Charge (Goods Receiving Section)

17. INSPECTION & TESTING:

For Goods:

- Firm shall submit QAP for approval within 1 week of placement of order and shall be approved by MDL within 1 week from date of submission.
- Inspection will be carried out as per the approved QAP.
- INSPECTION AGENCY will TPI-NON IACS (NABCB) and TPI charges to be borne by MDL.TPI details are as follows: -
- Supplier Name: **M/s Certification Engineers INT Ltd, Navi Mumbai**
- Address:
Certification Engineers International Limited
(A Govt. of India Undertaking, Subsidiary of EIL)
Engineers India Bhawan, Plot No – 85, Sector – 11,
Kharghar, Navi Mumbai – 410210.
- Contact Details of Project Coordinator for execution part:
 - a) Project Manager:
Name: Mr. Mandar Deshpande
Email: mdeshpande@ceil.co.in
Mobile: +91 9769018481
 - b) Project Co-ordinator:
Name: Mr. Pravin Thorat
Email: pravinthorat@ceil.co.in
Mobile: +91 9892754724
- **Firm to visit the site for measurements prior to fabrication.** The measurement should be taken in presence of berth & CGRPT rep. The decision of the Inspecting Authority or their representatives, as the case may be, on any question of the intent, meaning and the scope of



Mazagon Dock Shipbuilders Limited, Mumbai

Additional Tender Terms and Conditions

Tender No. GEM/2026/B/7695386

Eligibility to bid: Class-I & II Local Supplier Only (Gaurd Rail Stanchions)

Type of tender: Open Tender

Specifications / Standards shall be final, conclusive and binding on the Bidder/ Supplier / Contractor.

- **Note: -ALL THE ITEMS ARE TO BE TAGGED WITH SEPARATE TALLY PLATES.**

Receipt Inspection: Receipt inspection will be carried out by MDL Inspection Department along with Coast Guard rep on receipt in the MDL premises on the basis of appropriate Inspection system requirements & the Inspection documents submitted by suppliers. Any objection raised by MDL inspection team against quality of material or workmanship shall be satisfactorily corrected by the supplier at his expenses including replacement as may be required within shortest possible time within 30 days. Items damaged during transit shall also be rectified or replaced by the supplier within shortest possible time.

Rejection of the material: Any portion of the equipment found defective/rejected, the supplier shall collect the same at his cost from the MDL Yard, all incidental charges being born by supplier, (inclusive of custom duty, if payable), within 30 days from the date of intimation to the supplier of such rejection. The MDL reserves the rights to dispose-off the rejected item at the end of a total period of 90 days in any manner, to the best advantage to the MDL & recover storage charges & any consequential damages, from sale proceeds of such disposal.

18. REVERSE AUCTION:

- a) MDL reserves the right to extend, reschedule, postpone, suspend/pause, resume and extend the Reverse Auction, or cancel the Reverse Auction process at any time, before ordering, without assigning any reason, with intimation to bidders.
- b) If the lowest price received during ERA is unreasonable or it is unacceptable on ground of being too high when compared with estimated price, MDL reserves the right to seek justification of the price from lowest bidder.
- c) If the price is not considered reasonable, MDL may not accept such bid and can go for another tender process. MDL reserves the right to cancel the tender cum RA process.

19. **PUBLIC GRIEVANCE CELL:** A public grievance cell headed by Shri R. R. Kumar, ED (P) has been set up in the company. Members of public having complaints or grievances are advised to contact above Authorities on Wednesday between 10.00 hours and 12.30 hours in his office at 3rd Floor, West Block, Mazagon Dock Shipbuilders Ltd or send their complaints / grievances to him in writing for redressal. Telephone No. is 022-23763512(MDL).



Mazagon Dock Shipbuilders Limited, Mumbai

Additional Tender Terms and Conditions

Tender No. GEM/2026/B/7695386

Eligibility to bid: Class-I & II Local Supplier Only (Gaurd Rail Stanchions)

Type of tender: Open Tender

20. **BREACH OF OBLIGATION:** In case of breach of any obligation mentioned under, the bidder shall be disqualified / debarred from the bidding process for a period of one year from the date of notification;
- Bidder has withdrawn / modified / amended / impaired / derogated from the tender during the period of bid validity.
 - Bidder fails or refuses to execute the contract upon notification of acceptance of bid by MDL during the period of bid validity.

21. **RIGHT TO REJECT ANY OR ALL BIDS:**

MDL reserves its right to accept or reject any or all Bids, abandon/ cancel the Tender process, and issue another tender for the same or similar Goods/Services at any time before the award of the contract. It would have no liability to the affected Bidder or Bidders or any obligation to inform the affected Bidder or Bidders of the grounds for such action(s).

22. **CANCELLATION OF PROCUREMENT PROCESS/ REJECTION OF ALL BIDS/RE-TENDER:** If competition is lacking, then in such cases lack of competition shall not be determined solely on the basis of the number of Bidders. Even when only one Bid is submitted, the process may be considered valid provided following conditions are satisfied:

- The procurement was satisfactorily advertised and sufficient time was given for submission of bids.
- The qualification criteria were not unduly restrictive; and
- Prices are reasonable in comparison to market values

The decision to cancel the procurement and reasons for such a decision shall be communicated to all bidders that participated in the procurement process. During Re-tendering, all participated bidders of earlier tender shall be informed.

23. **CONFLICT OF INTEREST AMONG BIDDERS/ AGENTS:** A bidder shall not have conflict of interest with other bidders. Such conflict of interest can lead to anti-competitive practices to the detriment of MDL's interests. The bidder found to have a conflict of interest shall be disqualified. A bidder may be considered to have a conflict of interest with one or more parties in this bidding process, if:

- they have controlling partner (s) in common; or
- they receive or have received any direct or indirect subsidy/ financial stake from any of them; or
- they have the same legal representative/agent for purposes of this bid; or
- they have relationship with each other, directly or through common third parties, that puts them in a position to have access to information about or influence on the bid of another Bidder; or
- Bidder participates in more than one bid in this bidding process. Participation by a Bidder in more than one Bid will result in the disqualification of all bids in which the parties are involved. However, this does not limit the inclusion of the components/ sub-assembly/ Assemblies from one bidding manufacturer in more than one bid.
- In cases of agents quoting in offshore procurements, on behalf of their principal manufacturers, one agent cannot represent two manufacturers or quote on their



Mazagon Dock Shipbuilders Limited, Mumbai

Additional Tender Terms and Conditions

Tender No. GEM/2026/B/7695386

Eligibility to bid: Class-I & II Local Supplier Only (Gaurd Rail Stanchions)

Type of tender: Open Tender

behalf in a particular tender enquiry. One manufacturer can also authorise only one agent/dealer. There can be only one bid from the following:

1. The principal manufacturer directly or through one Indian agent on his behalf; and
2. Indian/foreign agent on behalf of only one principal.

(vii) Bidder or any of its affiliates participated as a consultant in the preparation of the design or technical specifications of the contract that is the subject of the Bid;

(viii) In case of a holding company having more than one independently manufacturing units, or more than one unit having common business ownership/management, only one unit should quote. Similar restrictions would apply to closely related sister companies. Bidders must proactively declare such sister/ common business/ management units in same/ similar line of business

Note: The undertaking by the bidders for above para (Conflict of Interest among Bidders/ Agents) shall be submitted/uploaded along with Part I bid.

24. CORRIGENDUM TO TENDER DOCUMENT: Before the deadline for submitting bids, MDL may update, amend, modify, or supplement the information, assessment or assumptions contained in the Tender Document by issuing a corrigendum. The corrigendum shall be published in the same manner as the original Tender Document. Without any liability or obligation, the Portal may send intimation of such corrigendum to bidders who have downloaded the document under their login. However, the bidders' responsibility is to check the website(s) for any corrigendum. Any corrigendum thus issued shall be considered a part of the Tender Document. To give reasonable time to the prospective bidders to take such corrigendum into account in preparing their bids, MDL may suitably extend the deadline for the bid submission, as necessary. After MDL makes such modifications, any Bidder who has submitted his bid in response to the original invitation shall have the opportunity to either withdraw his bid or re-submit his bid superseding the original bid within the extended time of submission.

25. CONTACTING MDL DURING THE EVALUATION: If a Bidder needs to contact MDL for any reason relating to this tender and/ or its bid, it should do so only in writing or electronically. Any effort by a Bidder to influence MDL during the processing of bids, evaluation, bid comparison or award decisions shall be construed as a violation of the Code of Integrity, and bid shall be liable to be rejected as nonresponsive in addition to other punitive actions for violation of Code of Integrity as per the Tender Document.

26. CARTEL FORMATION/POOL RATES:

It is possible that sometimes a group of bidders quote the same rate against a tender. Such pool/cartel formation is against the basic principle of competitive bidding and defeats the very purpose of an open and competitive tendering system. Such and similar tactics to avoid/control true competition in a tender leading to "Appreciable Adverse Effect on Competition" (AAEC) have been declared as an offence under the Competition Act, 2002, as amended by the Competition



Mazagon Dock Shipbuilders Limited, Mumbai

Additional Tender Terms and Conditions

Tender No. GEM/2026/B/7695386

Eligibility to bid: Class-I & II Local Supplier Only (Gaurd Rail Stanchions)

Type of tender: Open Tender

(Amendment) Act, 2007. Such practices should be severely discouraged with strong measures. In case of evidence of cartel formation, detailed cost analysis may be done by associating experts if necessary. Besides, suitable administrative actions can be resorted to, such as rejecting the offers, reporting the matter to trade associations, the Competition Commission or NSIC, etc., and requesting them, inter-alia, to take suitable strong actions against such firms. New firms may also be encouraged to get themselves registered for the subject goods to break the monopolistic attitude of the firms forming a cartel. Changes in the mode of procurement (GTE instead of OTE) and packaging/slicing of the tendered quantity and items may also be tried. A warning clause may also be included in the bid documents to discourage the bidders from indulging in such practices. Purchaser may also debar the tenderers indulging in cartel formation/collusive bidding/bid rigging for a period of two years from participation in the tenders of the Purchaser.

27. **CONTACT DETAILS FOR QUERIES: All bidders are requested to get their queries, if any, clarified in advance (i.e. 7 days in advance to tender closing date) to avoid last minute delay.** In case of any clarifications regarding tender, bidders are requested to contact the following executives.

Department	Name of Executives	Contact No	Email
Technical	Mr. Bhupendra G Chandekar	022-2376 3105	bchandekar@mazdock.com
	Mr. Ramesh Chandra Rout	022-2376 3362	rcrout@mazdock.com
Commercial	Mr. D S Chavan	022-2376 2782	dschavan@mazdock.com
	Mr. Sachin Kumar	022-2376 2764	sachinkumar@mazdock.com

28. We look forward to receive your most competitive and reasonable offer against this tender.

Yours faithfully,
For MAZAGON DOCK SHIPBUILDERS LIMITED

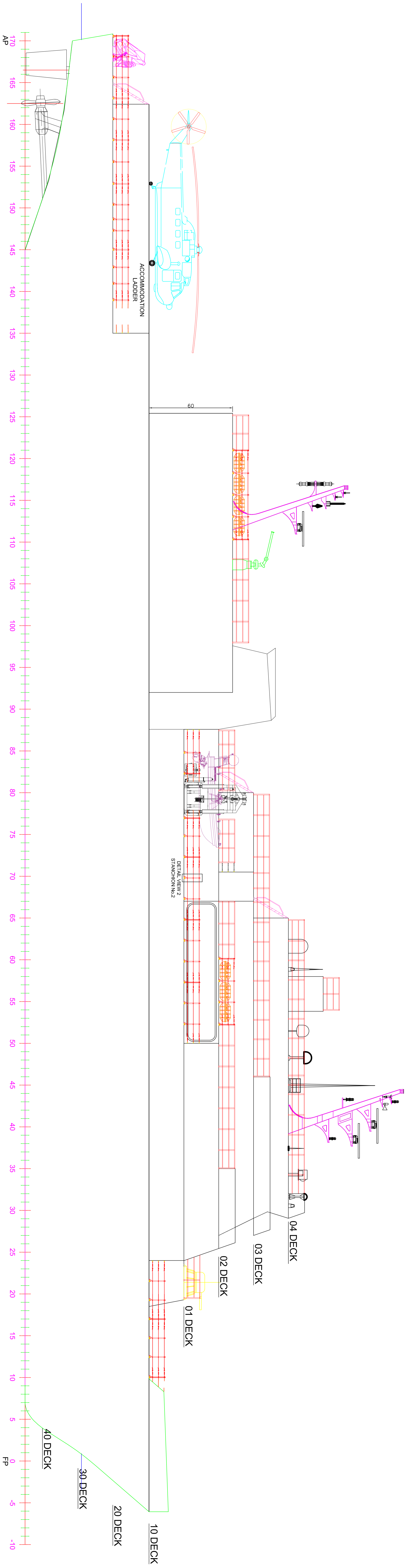

PROFILE VIEW (STBD)

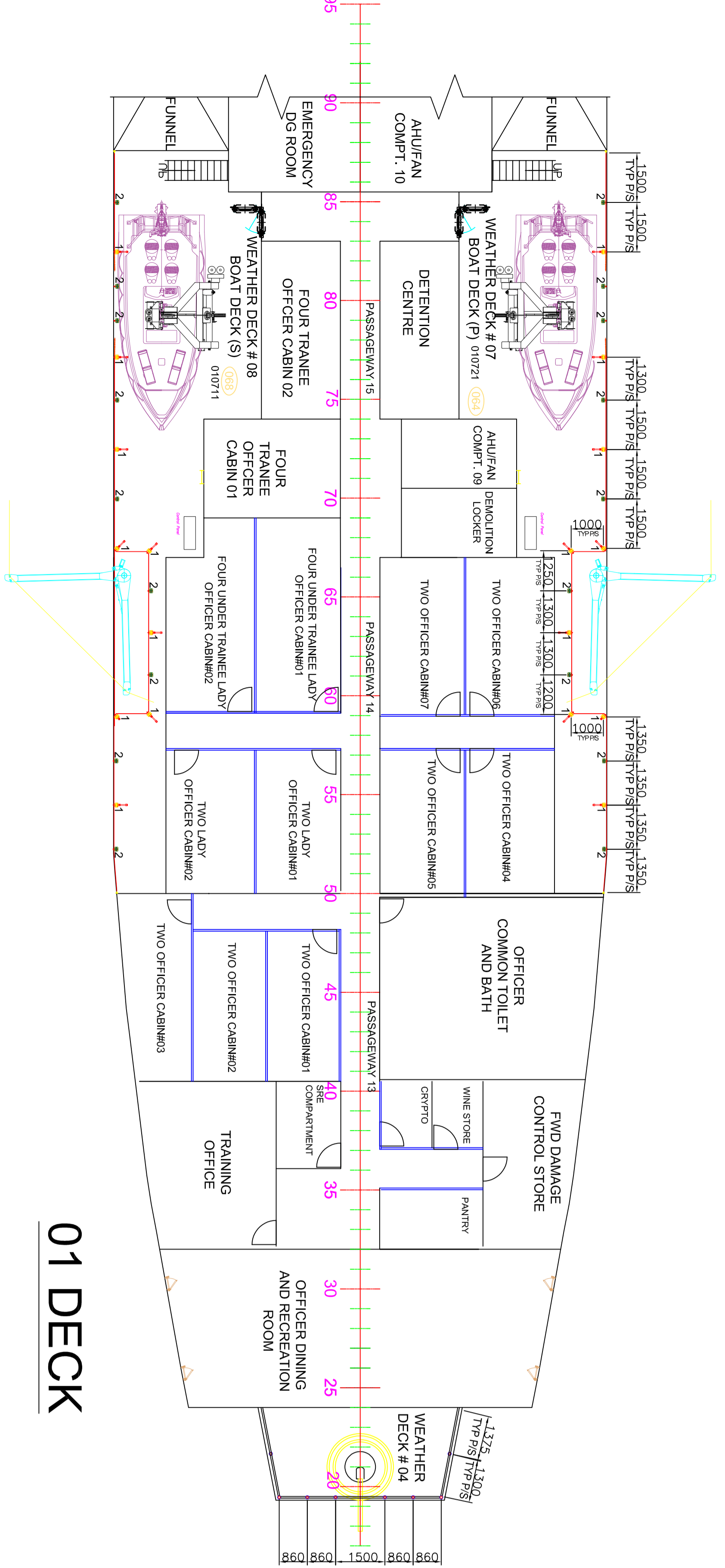

01 DECK

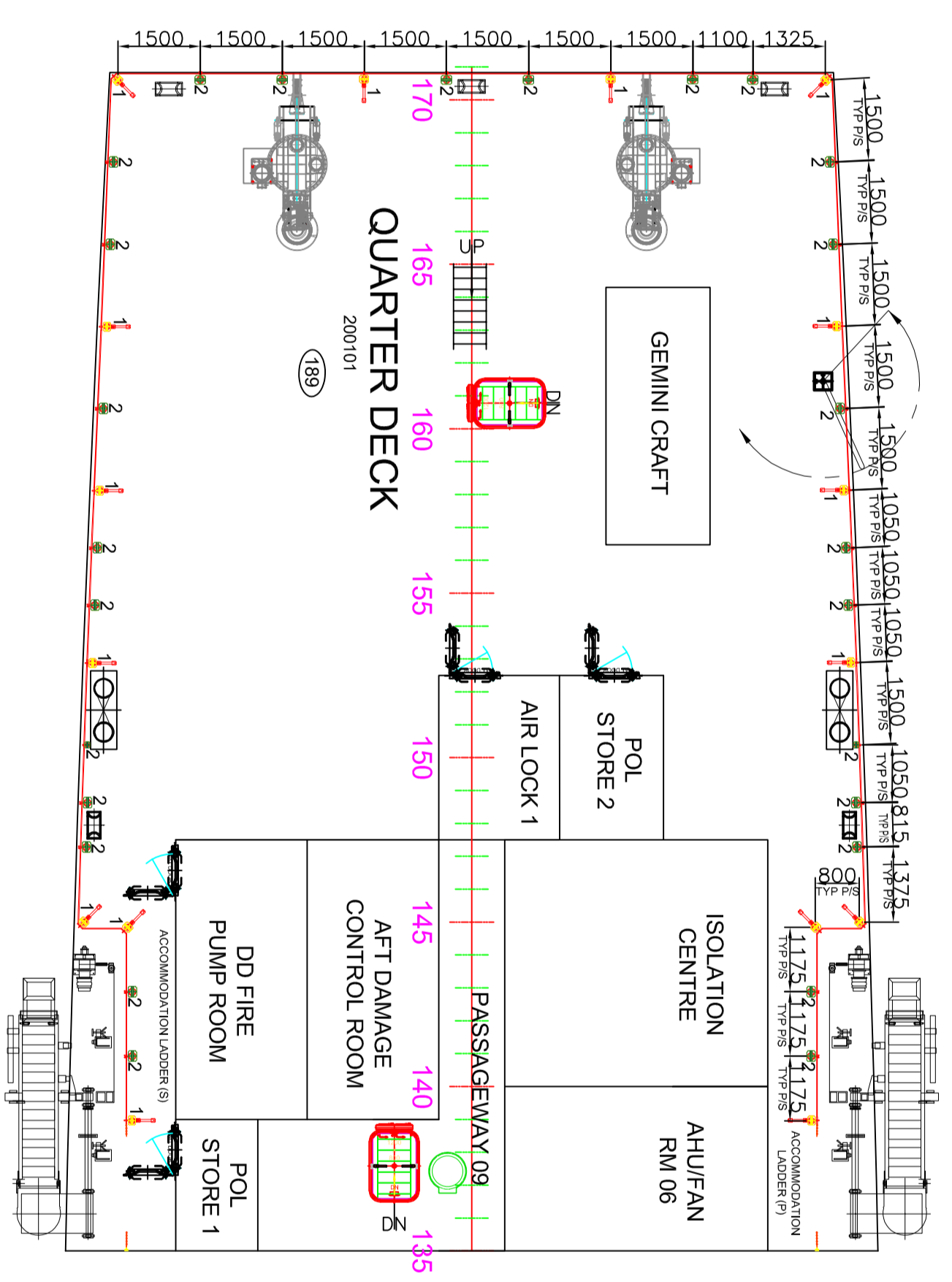

20 DECK

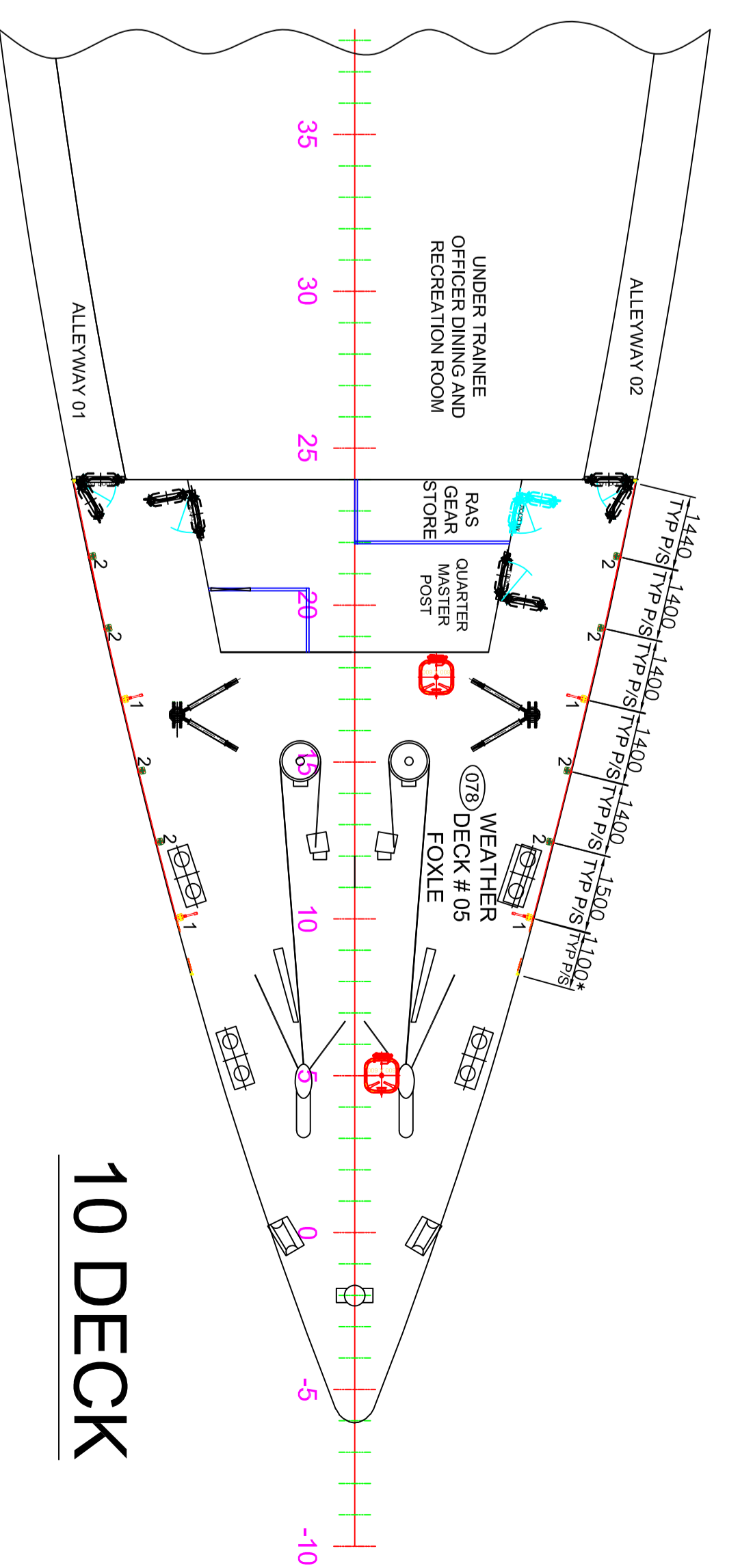

10 DECK

Sr. No.	LOCALITY	STANCH. TYPE '1'	STANCH. TYPE '2'	STAY	TURN BUCKLE MFR.	CHAIN PICES	WIRE-Ø14 ROPE:M.	WIRE-Ø10 ROPE:M.	EYE PLATES	REMARKS
1	04 DK. WHEEL HOUSE TOP	-	-	-	4	105	-	-	6	
2	03 DK. WEATHER DK.01	-	-	-	4	105	-	-	6	
3	02 DK. WEATHER DK.03 HANGAR TOP	10	6	10	48	4	105	18	36	6
4	02 DK. TRAINER BRIDGE WING PORT	4	2	4	18	-	7	14	-	
5	02 DK. TRAINER BRIDGE WING STBD	4	2	4	18	-	7	14	-	
6	02 DK. WEATHER DK.02	-	-	-	14	370	-	-	-	
7	02 DK. BOAT EMBARRICATION PLATFORM (P)	-	-	-	14	370	-	-	24	
8	02 DK. BOAT EMBARRICATION PLATFORM (S)	-	-	-	4	105	-	-	24	
9	01 DK. WEATHER DK.07 BOAT DK. PORT	6	12	6	30	10	270	23	46	6
10	01 DK. WEATHER DK.08 BOAT DK. STBD	6	12	6	30	10	270	23	46	6
11	10 DK. WEATHER DK.05 FOXLE	4	8	4	24	6	182	18	36	12
12	20 DK. QUARTER DK.	14	30	14	90	15	405	56	112	6
TOTAL		48	72	48	258	85	2267	152	304	96
EXTRA		12	18	12	52	20	453	48	96	24
GRAND TOTAL		60	90	60	310	105	2720	200	400	120

SAP No.15000000000089838 MATERIAL FOR GUARD RAIL

DRAWING APPROVED BY ABS VIDE LETTER NO.W00241403 DATE:-10-APR-2025.
 DRAWING APPROVED BY IBS VIDE LETTER NO.E-253198-336557 DATE:-02-APR-2025.

- NOTE:
1. ALL DIMENSIONS ARE IN mm.
 2. * IS MENTION FOR DIMENSION WHICH ARE SUITE AT SITE.
 3. STANCHION TEST LOAD SHOULDNT BE LESS THAN 760 KG I.A.W INBR 1652 REV 2.0 FURTHER GUARDRAIL BREAKING STRENGTH LOAD SHOULDNT BE LESS THAN 2.5 TONS & PAINTER ROOM MAY BE MODIFIED TO SUIT AT SITE REQUIREMENTS AS PER CLASS RULES
 5. DOUBLE PVC COATED FSMR TO BE PROVIDED AS GUARDRAIL.
 - 6 CHAIN FOR SECURING DROP NOSE PIN WELD WITH STANCHION BONDING STRAP ALSO TO BE PROVIDED ON ALL STANCHIONS STAY.

04	ALL COMMENTS INCORPORATED AS PER COHD LETTER SA/0157/015/HUI	MDL	14/11/25	GSP/ISP
03	ALL COMMENTS INCORPORATED AS PER COHD LETTER SA/0157/015/HUI	MDL	03/10/25	GSP/ISP
02	ALL COMMENTS INCORPORATED AS PER COHD LETTER SA/0157/015/HUI	MDL	08/08/25	GSP/ISP
01	ALL COMMENTS INCORPORATED AS PER IBS LETTER NOE-253198-336557 DATED 02 APR 2025 & ABS LETTER NO.W00241403 DATED 10 APR 2025 & COHD LETTER NO. SA/0157/015/HUI Drg DATED 15 MAY 2025	MDL	01/07/25	GSP/ISP

 MAVA GON DOCK SHIPRETTIDERS LIMITED DOCKROAD ROAD Wanchi 400 010	CLIENT INDIAN CONST GUARD	SHIP TRAINING SHIP
TITLE GUARD RAIL & STANCHIONS ARRANGEMENT ON WEATHER DECKS		

SCALE	SCALE	SCALE	SCALE	SCALE
NAME	DESIGN	DRWN	CHECKED	SEC. HEAD
G.S.P/MAR	D.VANU-FJ	T.S.P/ML	D.VANU-FJ	K.RAJUPT
1:6	1:10	1:10	1:10	1:1
04-03-2025				
DRAWING NUMBER	140101	SHEET	01	OF
REV	1			

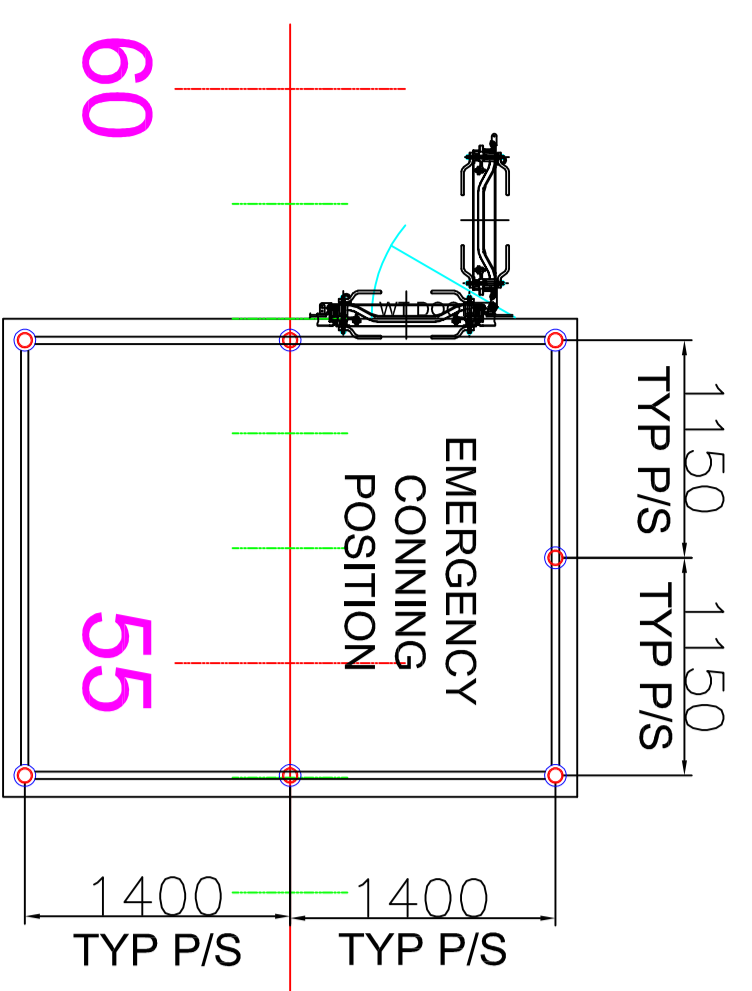

05 DECK

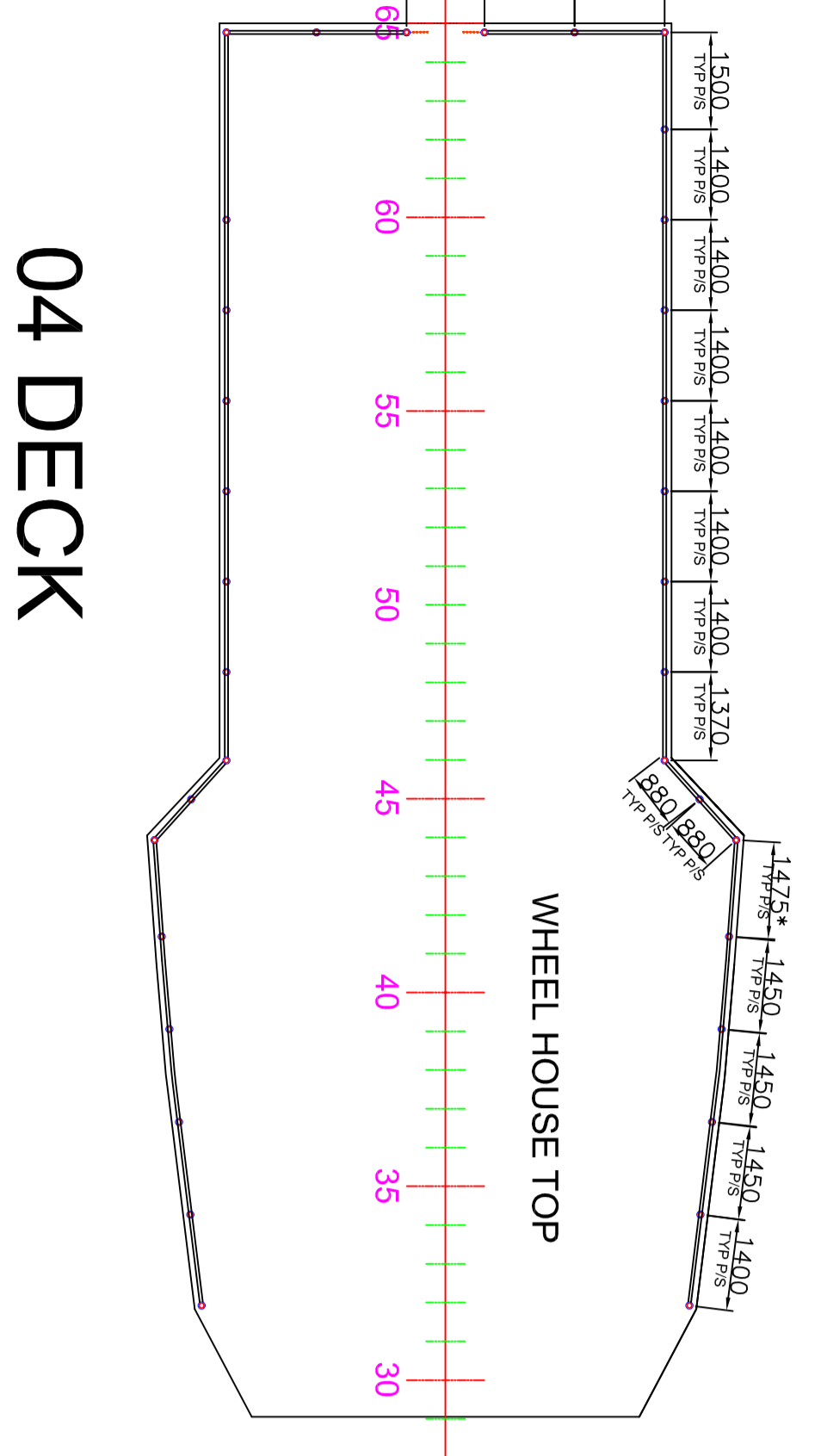

04 DECK

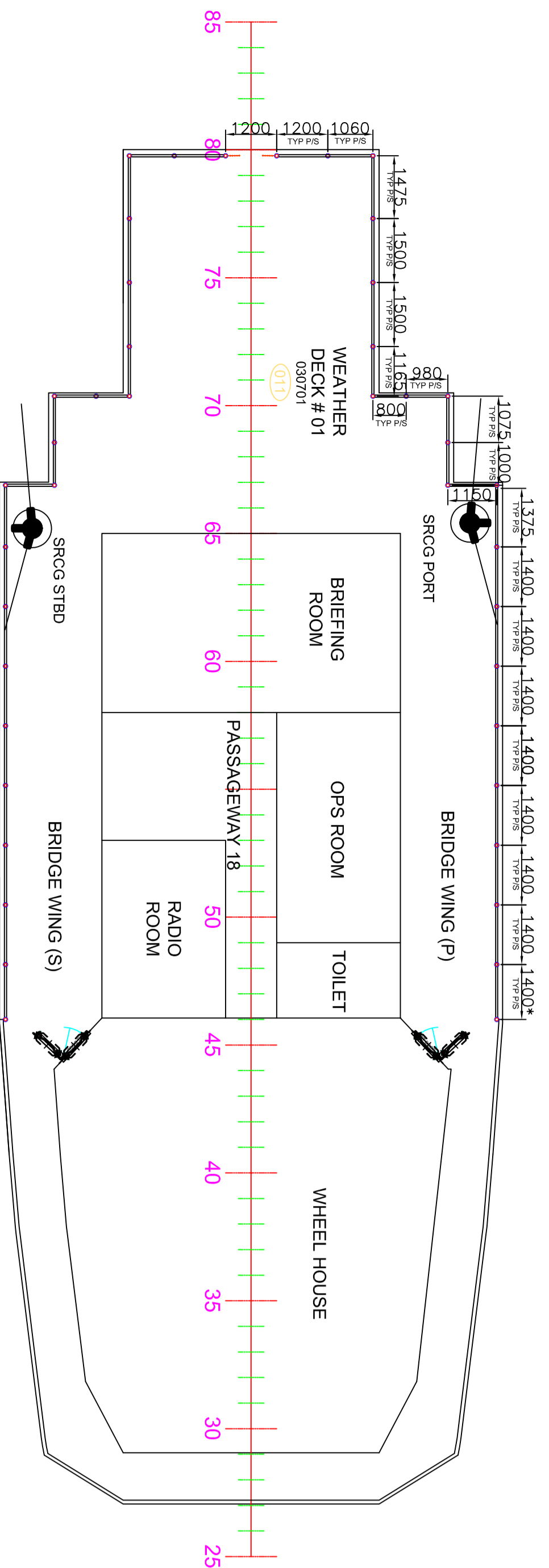

03 DECK

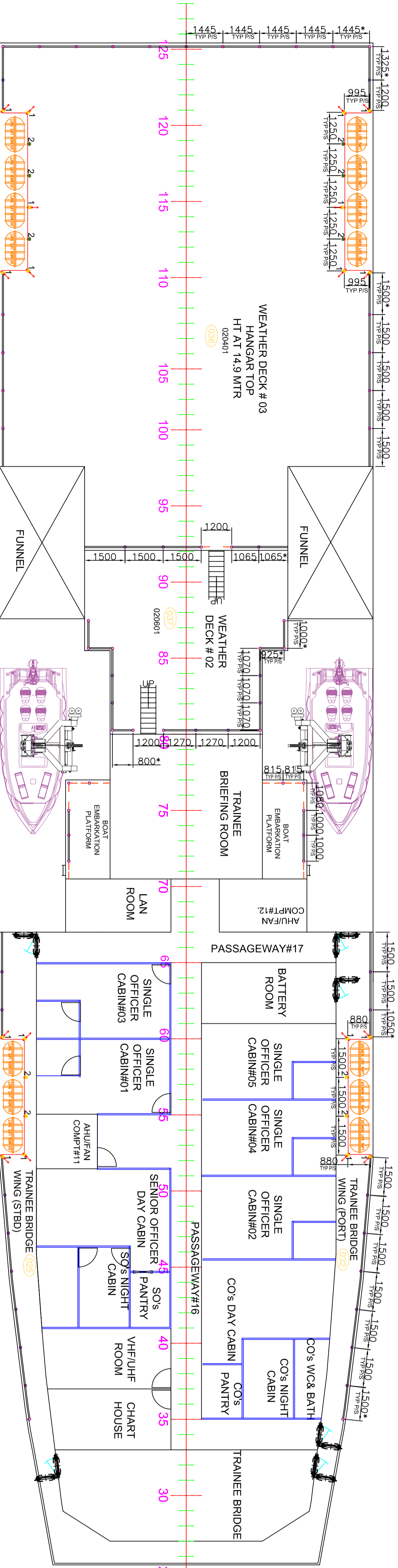

02 DECK

SAP No. 15000000000089838 MATERIAL FOR GUARD RAIL

DRAWING APPROVED BY ABS WIDE LETTER NO.W0241403 DATE:-10-APR-2025.
DRAWING APPROVED BY IRS WIDE LETTER NO.E-263198-336657 DATE:-02-APR-2025.

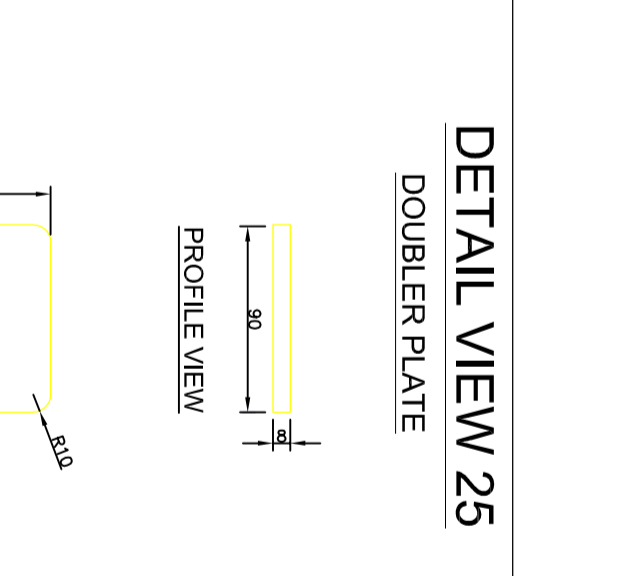
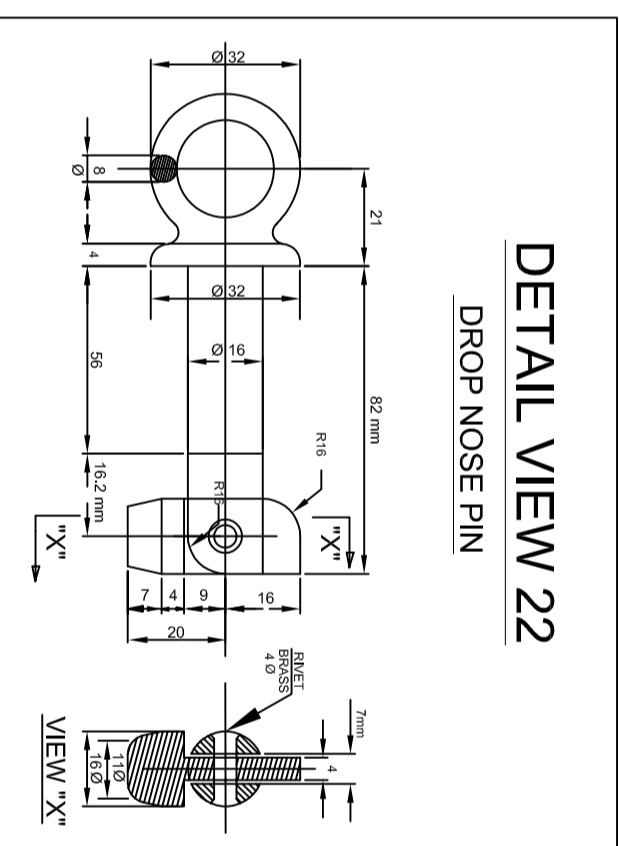
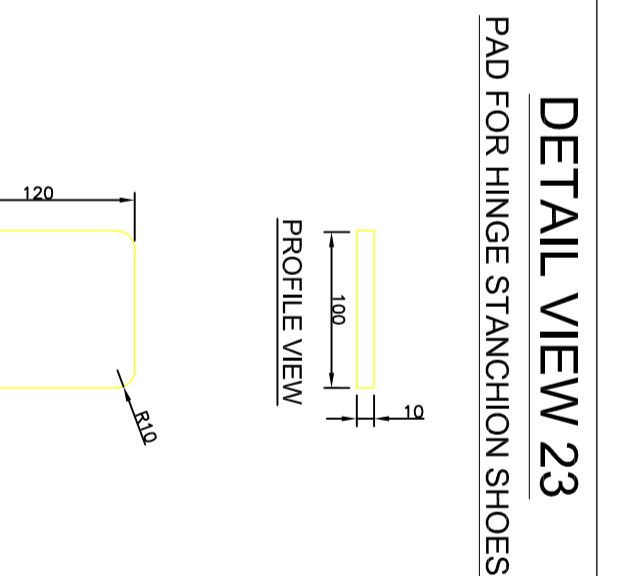
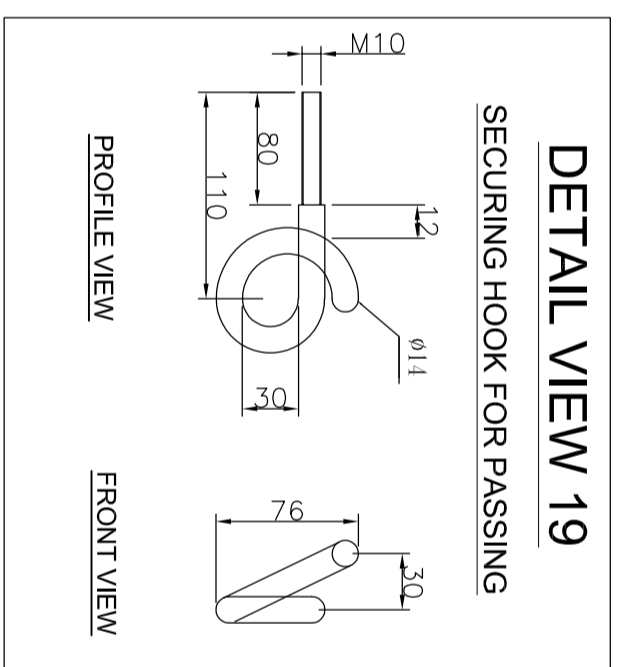
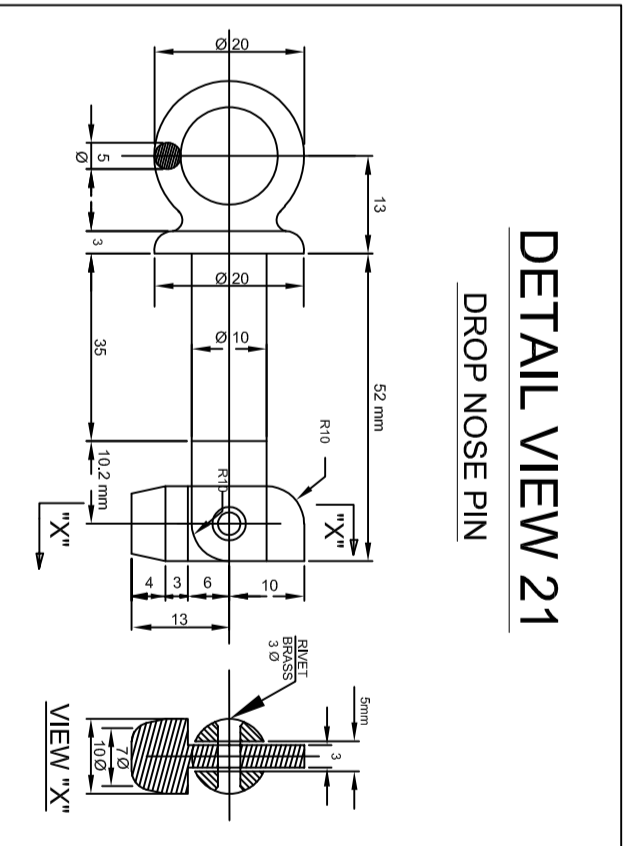
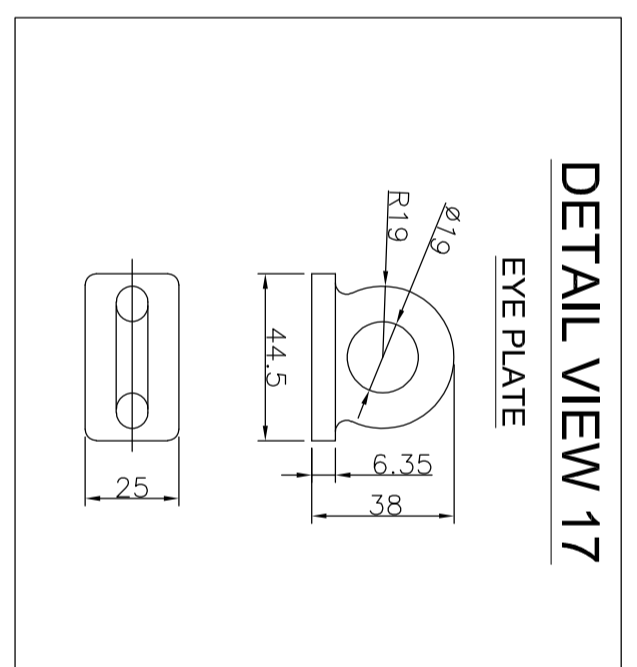
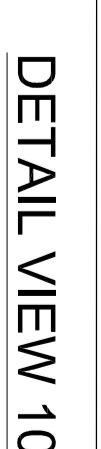
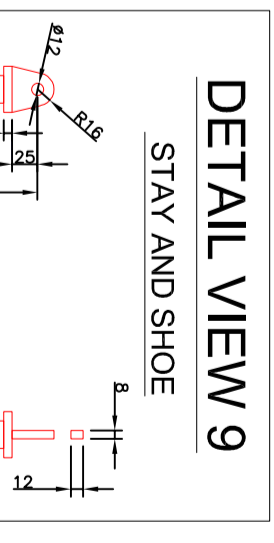
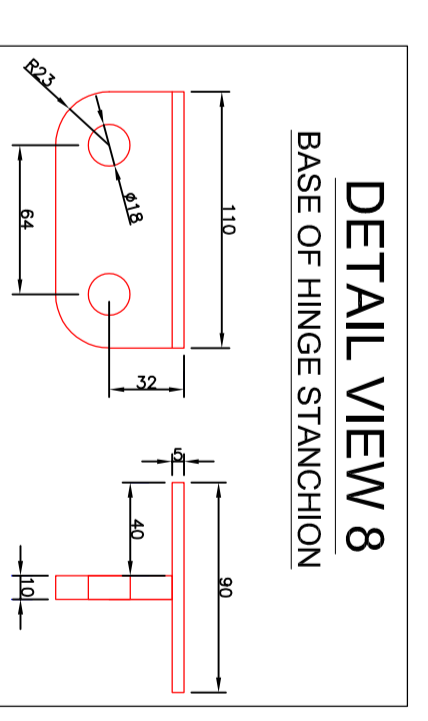
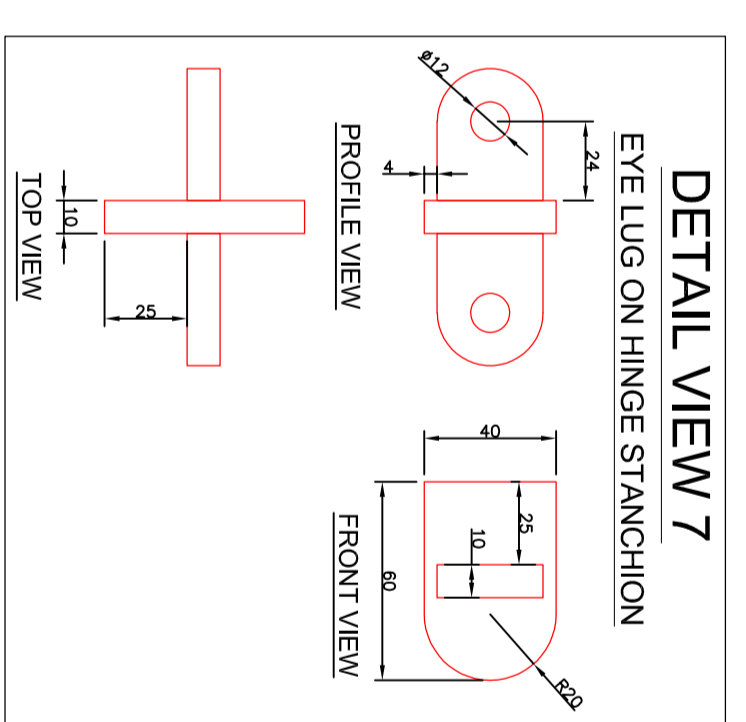
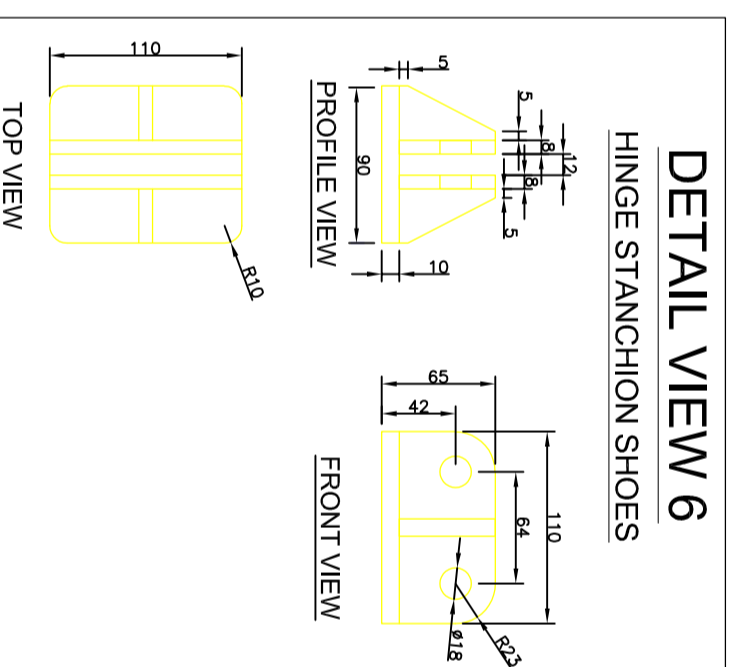
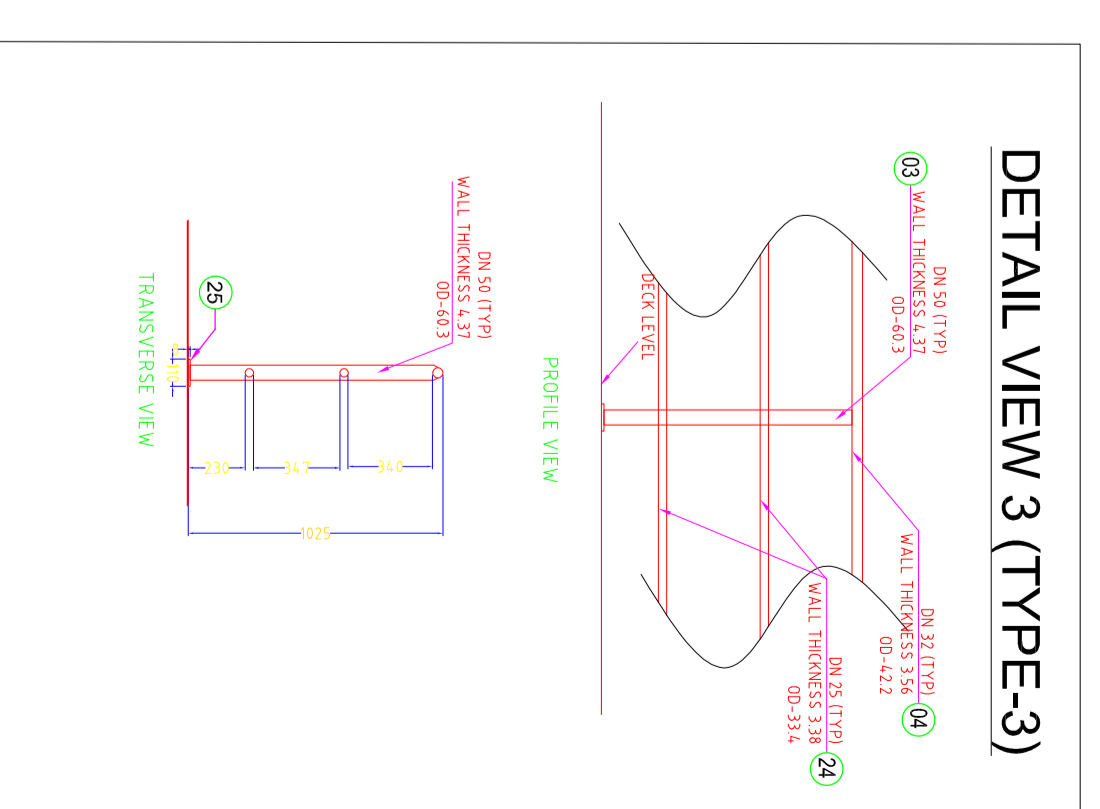
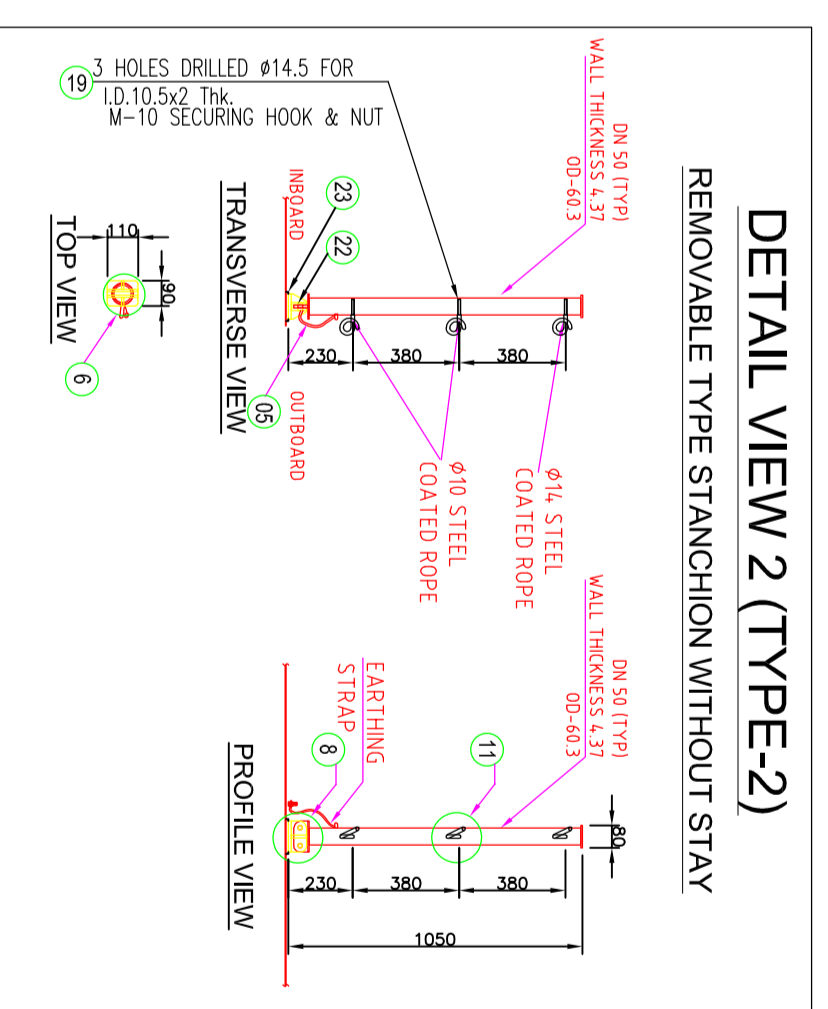
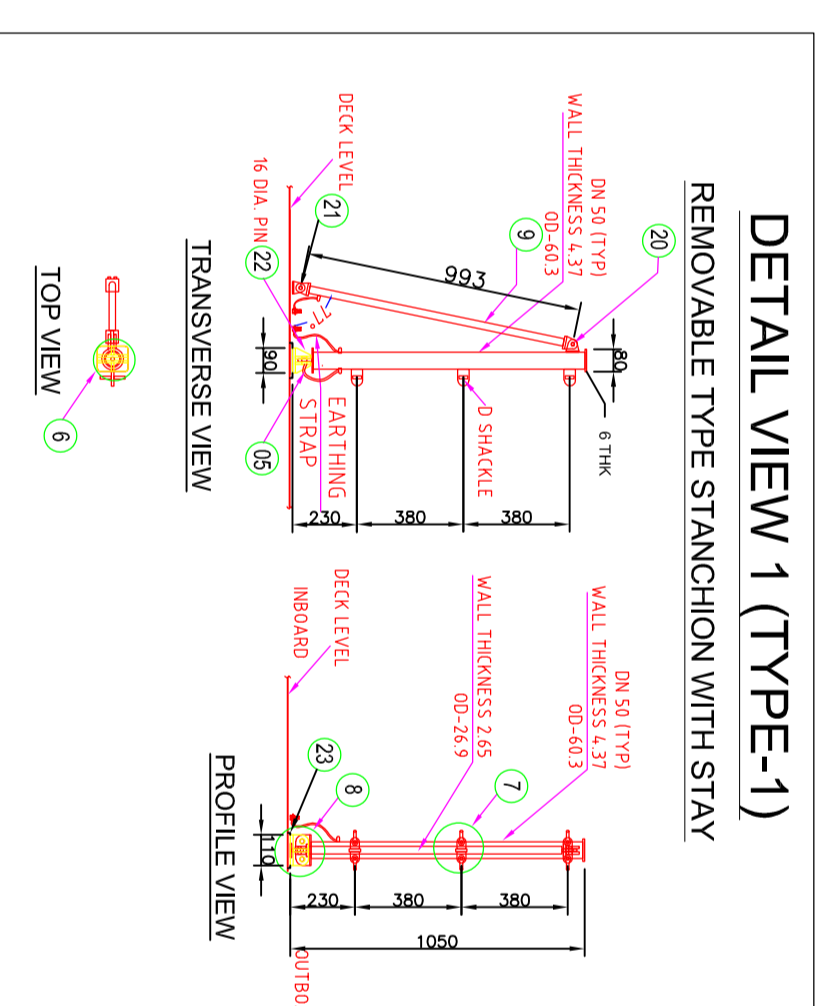
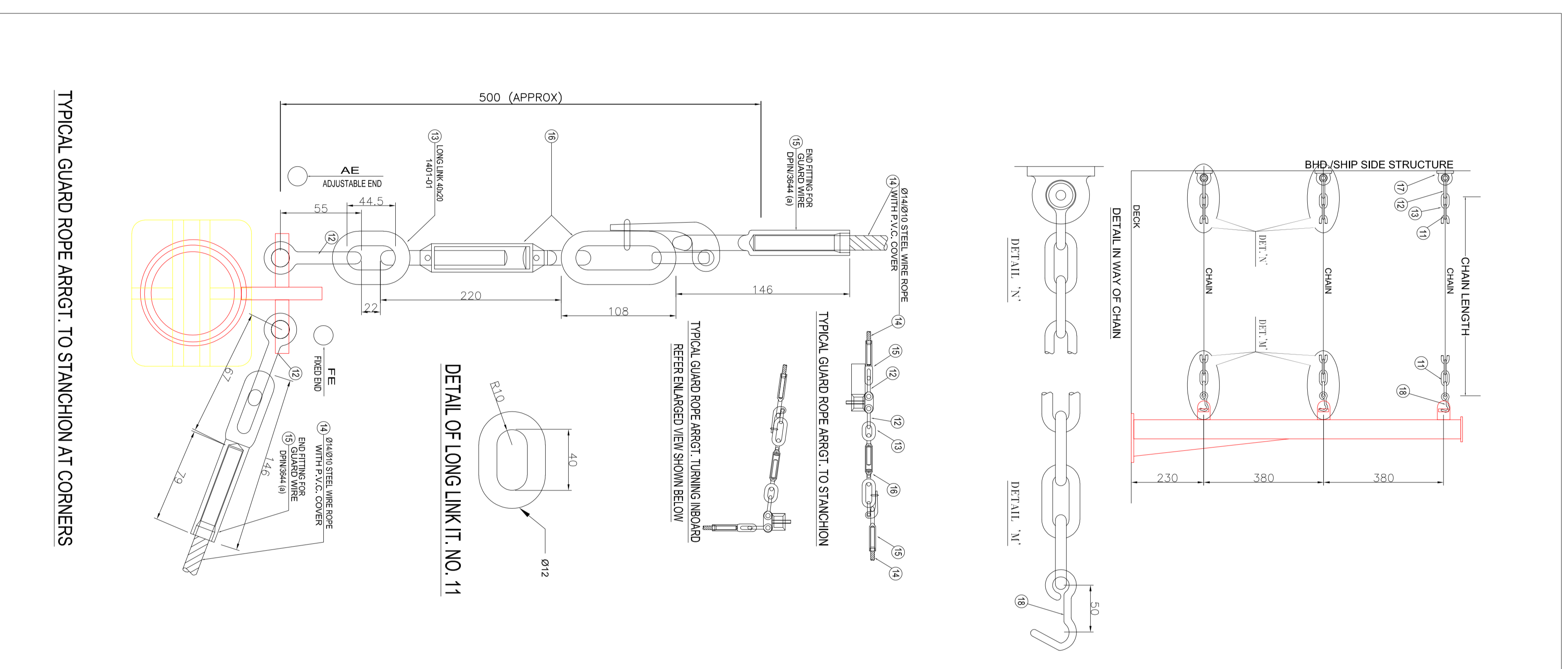
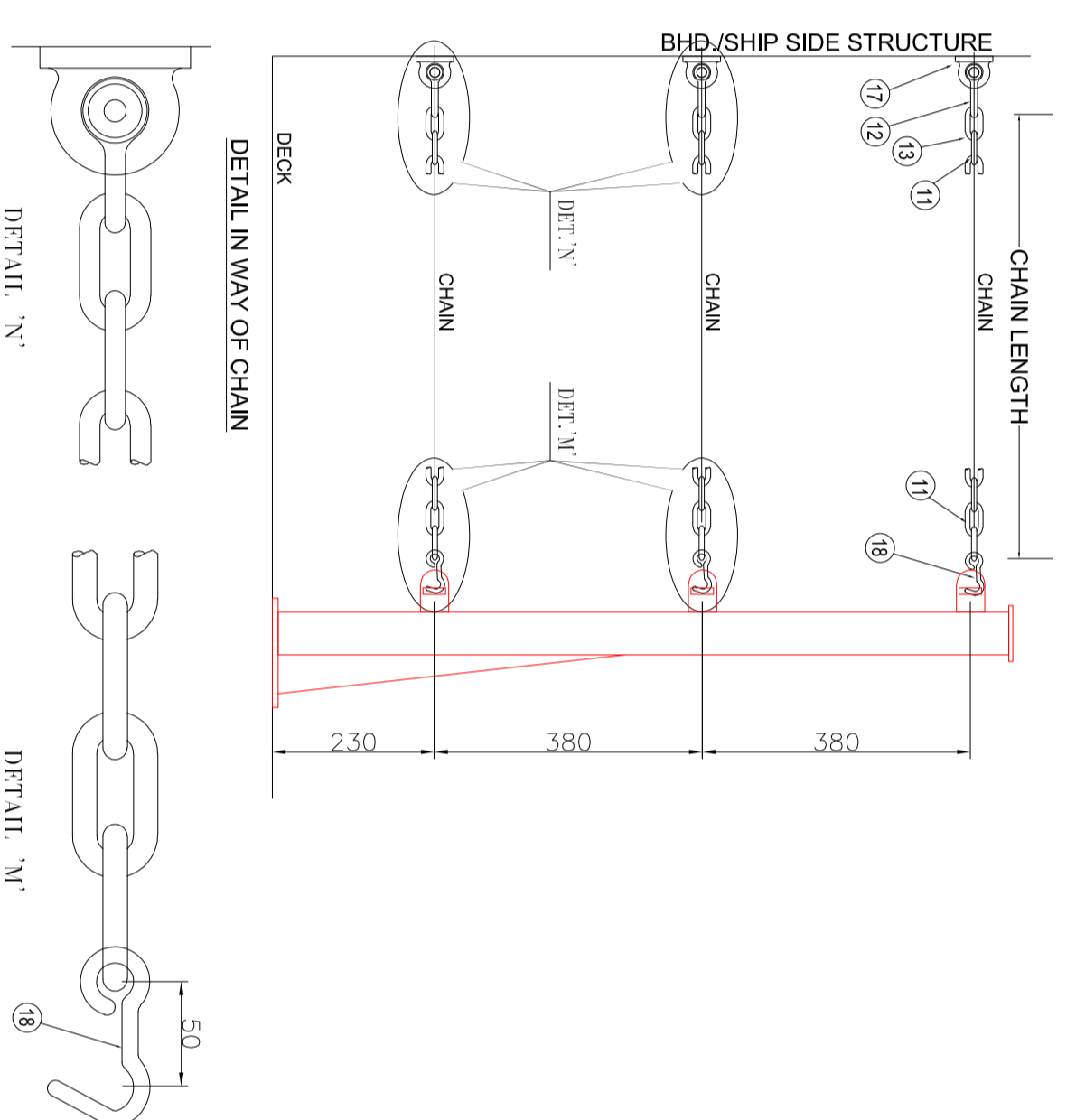

SIR	NO.	DESCRIPTION	PATT. NO.	MATL.	QTY.	REMARK
	25	DOUBLER PLATE (90 X 50 X 8 THK)		M.S. Gdnd.	260 Nos.	
	24	PIPE OD-33.4 (WALL THK 3.80)		M.S. AISI 316	660 Mtrs.	
	23	PAD FOR HINGE STANCHION SHOE		S.S. AISI 316	150 Nos.	TYPE 1 & 2 STN
	22	Ø 16 DROP NOSE PIN		NAVAL BRASS	150 Nos.	TYPE 1 & 2 STN
	21	Ø 10 DROP NOSE PIN		NAVAL BRASS	80 Nos.	DETAIL VIEW 9
	20	M10 NUT BOLT & WASHER III		S.S. AISI 316	60 Nos.	TYPE 1 STN.
	19	SECURING HOOK FOR PASSING(WITH M10 NUT & WASHER III)		S.S. AISI 316	270 Nos.	TYPE 2 STN.
	18	HOOK Ø10 ROD	1.S. 2082	S.S. AISI 316	40 Nos.	TYPE 2 STN.
	17	EYE PLATE	0262/419-5140	S.S. AISI 316	120 Nos.	TYPE 1 STN.
	16	SCREW WITH SUP/BOTH SIDE EXTENDABLE WITH SAFETY LOCK PIN	0263/414-8836	S.S. AISI 316	310 Nos.	DPIN/569 (g)
	15	END FITTING FOR		S.S. AISI 316	310 Nos.	
	14B	Ø10 STEEL WIRE ROPE		S.S. AISI 316	400 Mtrs.	GRADE OR EQUIVALENT
	14A	Ø14 STEEL WIRE ROPE	1.S. 2429	S.S. AISI 316	200 Mtrs.	GRADE OR EQUIVALENT
	13	LONG LINK 40x20xØ12	0263/414-9447	S.S. AISI 316	310 Nos.	AS SHOWN
	12	SHACKLE BOW	0222/571-6218	S.S. AISI 316	310 Nos.	DPIN/1587 (g)
	11	CHAIN (RIGGING) OPEN LINK Ø10	0222/571-6220	STEELGR. 30	105 Mtrs.	
	09	STAY & SHOE		M.S. Gdnd.	60 Nos.	MATL TO BE RESABS
	08	BASE ON HINGE STANCHION		M.S. Gdnd.	180 Nos.	GRADE OR EQUIVALENT
	07	EYE LUG ON HINGE STANCHION		S.S. AISI 316	180 Nos.	MATL TO BE RESABS
	06	HINGE STANCHION SHOES		M.S. Gdnd.	150 Nos.	GRADE OR EQUIVALENT
	05	CHAIN FOR SECURING DROP NOSE PIN		S.S. AISI 316	110 Mtrs.	DETAIL VIEW 21, 22
	04	PIPE OD-42.2 (WALL THK 3.80)		M.S. Gdnd.	280 Mtrs.	GRADE OR EQUIVALENT
	03	PIPE OD-60.3 (WALL THK 4.37)		M.S. Gdnd.	280 Mtrs.	GRADE OR EQUIVALENT
	02	REMOVABLE TYPE STANCHION WITHOUT STAY		M.S. Gdnd.	90 Nos.	MATL TO BE RESABS
	01	REMOVABLE TYPE STANCHION WITH STAY		M.S. Gdnd.	60 Nos.	MATL TO BE RESABS

- NOTE:
1. ALL DIMENSIONS ARE IN MM.
 2. * S MENTION FOR DIMENSION WHICH ARE SUITE AT SITE.
 3. STANCHION FEET LOAD SHOULDNT BE LESS THAN 780 KG.
 4. GUARDRAIL & STANCHIONS SHOWN NEAR DAUGHTS & PAINTROOM MAY BE MODIFIED TO SUIT AT SITE.
 5. DOUBLE PVC COATED FSWR TO BE PROVIDED AS GUARDRAIL.
 6. SECURING DROP NOSE PIN YIELD WITH STANCHIONS STAY.
 7. EARTHING BONDING STRAP ALSO TO BE PROVIDED ON ALL STANCHIONS STAY.

NO.	DESCRIPTION	DATE	BY	CHKD.	APPD.
04	ALL COMMENTS INCORPORATED AS PER CGHQ LETTER SA/0157/0175/HUI	14/11/25	CSF/PSF		
03	ALL COMMENTS Drg DATED 07 NOV 2025 ARE INCORPORATED	03/10/25	CSF/PSF		
02	ALL COMMENTS Drg DATED 22 SEPT 2025 ARE INCORPORATED	08/08/25	CSF/PSF		
01	ALL COMMENTS INCORPORATED AS PER IRS LETTER NGE-253198-335557 DATED 02 APR 2025 & ABS LETTER NW-W00241403 DATED 10 APR 2025 & CGHQ LETTER NO. SA/0157/0175/HUI Drg DATED 15 MAY 2025	01/07/25	CSF/PSF		

SCALE	DRWN	CHECKED	SEC. HEAD	YARD NUMBER	DRAWING NUMBER	REV.
NTS	G.S.MANAR	T.S.PATEL	K.RAJPUT	16101	140101	1
	DESIGN	DRAWN(0-F)	QA(0-F)	04-03-2025	SHEET	02 OF 02

CLIENT	SHIP
MAVAGON DOCK SHIPRETTIDES LIMITED	TRAINING SHIP
INDIAN CONST GUARD	
GIARD RAIL & STANCHIONS ARRANGEMENT ON WEATHER DECKS	

LIST OF BANKS

Nationalized Banks/Public Sector Bank

1. Allahabad Bank
2. Andhra Bank
3. Bank of Baroda
4. Bank of India
5. Bank of Maharashtra
6. Canara Bank
7. Central Bank of India
8. Corporation Bank
9. Dena Bank
10. IDBI Bank
11. Indian Bank
12. Indian Overseas Bank
13. Oriental Bank of Commerce
14. Punjab & Sind Bank
15. Punjab National Bank
16. Syndicate Bank
17. State Bank of India
18. CO Bank
19. Union Bank of India
20. United Bank of India
21. Vijaya Bank
22. State Bank of India

List of Private Banks

1. Axis Bank
2. Federal Bank
3. HDFC Bank
4. ICICI Bank
5. IndusInd Bank
6. Kotak Mahindra Bank
7. Yes Bank
8. Karur Vysya Bank
9. IDFC Bank

FORM OF WARRANTY CERTIFICATE

In accordance with the Order N°..... Dated placed by MAZAGON DOCK SHIPBUILDERS LIMITED on _____(Name of firm)

_____ (Name of firm) certify that the following Items identified by the following references related to Yard Nos 11878, 11879 & 11880

Description of B&D Spares /Item(s) and Manufacturer’s Serial Number (OR any other such ID No) as per packing list no..... datedenclosed herewith

Bill of Lading/Air Way Bill no /Delivery Challan No. & Date.....

Covered by _____ (Name of firm) Invoice No & Date..... are warranted according to the terms and conditions as specified in the order.

The Date of issue of the certificate: DD/MM/YYYY

The Date of the end of validity of the guarantee: DD/MM/YYYY

For and on behalf of

COMPANY’S NAME & ADDRESS:

SIGNATURE :
DATE :
NAME :
DESIGNATION :
SUPPLIER’S COMPANY SEAL:

Order reference Number	
LC No.	
Corresponding to Invoice No & Date	
Packing List No. & Date	

PROFORMA BANK GUARANTEE FOR PERFORMANCE SECURITY

(ILLUSTRATIVE FORMAT)

(On Non-Judicial stamp paper of value Rs. 500/-. However, the value of stamp paper to be confirmed from Legal Department, MDL.)

IN CONSIDERATION OF MAZAGON DOCK SHIPBUILDERS LIMITED, a company incorporated under the Companies Act 1956 and having its registered office at Dockyard Road, Mumbai 400010 (hereinafter referred to as the "the Purchaser" which expression shall, unless it be repugnant or contrary to the subject or context thereof, be deemed to mean and include its successors and assigns) having placed an order on Messers a partnership firm/sole proprietor business/a company registered under the Companies Act, 1956 having its office at(hereinafter called " the Contractor/ Supplier" which expression shall, unless it be repugnant or contrary to the subject or context thereof, be deemed to mean and include its successors and assigns) vide order No..... dated..... (hereinafter called "the order" which expression shall include any amendments/alterations to "the order" issued by "the Purchaser") for the supply , delivery at site, installation and commissioning of certain equipment, item/services/civil works etc. as stated in the said Order and the Purchaser having agreed with the Contractor/Supplier to accept a Bank Guarantee in lieu of Performance Security payable under the said order for the fulfillment and performance of the said order, We, Bank having office at (hereinafter referred to as "the Bank" which expression shall include its successors and assigns) hereby agree to pay to the Purchaser without any demur on first demand an amount not exceeding Rs..... (Rupees.....only) being 5% (10% in case of Capital Procurement) of the order value against any loss or damage, costs, charges and expenses caused to or suffered by the Purchaser by reason of non performance and non-fulfillment or for any breach on the part of the Contractor / Supplier of any of the terms and conditions of the said order.

2. We, Bank further agree that the Purchaser shall be sole judge whether the said Contractor/Supplier has failed to perform or fulfil the said order in terms thereof or committed breach of any terms and conditions of the order and the extent of loss, damage, cost, charges and expenses suffered or incurred or would be suffered or incurred by the Purchaser on account thereof and we waive in the favour of the Purchaser all the rights and defences to which we as guarantors may be entitled to.

3. We, Bank further agree that the amount demanded by the Purchaser as such shall be final and binding on the Bank as to the Bank 's liability to pay and the amount demanded and the Bank undertake to pay the Purchaser the amount so demanded on first demand and without any demur notwithstanding any dispute raised by the Contractor/Supplier or any suit or other legal proceedings including arbitration pending before any court, tribunal or arbitrator relating thereto, our liability under this guarantee being absolute and unconditional.

4. We, Bank further agree with the Purchaser that the Purchaser shall have the fullest liberty without our consent and without affecting in any manner our obligations hereunder to vary any of the terms and conditions of the said order/or to extend time of performance by the Supplier from time to time or to postpone for any time to time any of the powers exercisable by the Purchaser against the Contractor/ Supplier and to forbear to enforce any of the terms and conditions relating to the order and we shall not be relieved from our liability by reason of any such variation or extension being granted to the Contractor/ Supplier or for any forbearance, act or omission on the part of the Purchaser or any indulgence by the Purchaser to the Contractor/Supplier or by any such matter or things whatsoever which under the law relating to sureties would have the effect of relieving us.

5. We, Bank further undertake not to revoke this guarantee during its currency except with the previous consent of the Purchaser in writing.

6. We, Bank also agree that the Bank's liability under this guarantee shall not be affected by any change in the constitution of the Contractor / Supplier or dissolution or winding up of the business of the contractor/ supplier.

7. Notwithstanding anything contained herein above:

i) Our liability under this guarantee shall not exceed Rs.....

ii) This Bank Guarantee shall be valid upto and including; and

iii) We are liable to pay the guarantee amount or any part thereof under this Bank Guarantee only and only if you serve upon us a written claim or demand on or before(validity + 4 weeks from the date of expiry of this guarantee).

8. This Guarantee shall be governed by Indian laws and the Courts at Mumbai, India shall have the exclusive jurisdiction.

IN WITNESS WHEREOF the Bank has executed this document on this.....day of

For Bank
(by its constituted attorney)
(Signature of a person authorised
to sign on behalf of "the Bank")

1. **MDL'S BANK ACCOUNT DETAILS:**

NAME OF BANK A/C HOLDER : **MAZAGON DOCK SHIPBUILDERS LTD**
BANK AND BRANCH : **STATE BANK OF INDIA, COMMERCIAL BRANCH, FORT, MUMBAI-400023**
TYPE OF ACCOUNT : **CURRENT**
BANK ACCOUNT NO : **11079519138**
IFSC CODE : **SBIN0006070**
SWIFT CODE : **SBININBB101**

2. **DETAILS OF REMITTANCE TO MDL'S BANK ACCOUNT:**

(To be filled in by the vendors/firms making remittance of funds in MDL'S Bank Account)

Date of Remittance	Name of Firm	Vendor Code	MDL tender/ PO. Ref No.	Nature of Remittance viz. EMD/SD etc.	Amount Remitted (₹)

Signature of Vendor/Representative

3. **SAP Parked Document No:** _____ **Date:** _____

(To be filled in by MDL's Commercial Executive)

Sr. No.2 and 3 above will be filled in by the Vendor and MDL commercial Executive respectively and the form forwarded to Treasury Section for posting of SAP Document to the respective Bank Account.



Enclosures

Enclosure for EXTRACT OF PROVISIONS OF THE OFFICIAL SECRETS ACT, 1923 (ILLUSTRATIVE FORMAT)

SECTION 2(B) : "PROHIBITED PLACE"

It is defined as the place of any work of Defence Dockyard and other so belonging or occupied and used for the purpose of building, repairing, making or storing any ammunitions of war.

For the purpose of the above definition, sketch includes any photograph or other mode of representing any place or thing.

SECTION 3 : "PENALTIES FOR SPYING"

If any per unlawfully -

- a) approaches, inspects, passes over or is in the vicinity of any clear place; or
- b) make any sketches intended to be directly or indirectly useful to an enemy ; or
- c) obtains, collects, records or communicates to any other person any secret official code.

Shall be liable for imprisonment of 14 years in case of Defence Installation.

SECTION 4 : "COMMUNICATION WITH FOREIGN AGENTS"

If Any person has been in communication with or attempted to communicate with foreign agents regarding the vital information of any "PROHIBITED PLACE" would be guilty of violating the provisions of this Act.

SECTION 5 : "WRONGFUL COMMUNICATION OF INFORMATION"

If any person having in his possession or control any official document;

- a) Willfully communicates to any person, other than a person, who is authorised to communicate it.
- b) Used the information in his possession for the benefit of any foreign power.
- c) Retain in his possession when he has no power to retain it
- d) Fails to take reasonable care of it.

Shall be guilty of an offence under this Act.

SECTION 6 : "UNAUTHORISED USE OF UNIFORMS"

If any person for the purpose of gaining admission or of assisting any other person to gain admission to a "PROHIBITED PLACE" wears uniforms without lawful authority shall be guilty of offence under this Section.

SECTION 7 : "INTERFERING WITH OFFICERS OF POLICE"

No person in the vicinity of any "PROHIBITED PLACE" shall abstract any Police Officer engaged on guard, sentry or similar duty. If any person move in the provisions of this section, shall be punishable with imprisonment, which may extend up to 3 years.

SECTION 8 : "DUTY OF GIVING INFORMATION"

It shall be duty of every person to give on demand to a superintendent of Police or any other Police Officer not below the rank of Inspector, any information in his power relating to an offence under this Act.

If any person fails to give such information, shall be punishable with imprisonment to 3 years or fine or with both.

SECTION 9 : "INCITEMENT"

Any person who attempts to commit or debate the commission of an offence under this Act shall be punishable with the same punishment and be liable to be proceeded against in the same manner as if he had committed such offence.

SECTION 10 : "PENALTY FOR HARBOURING SPIES"

If any person whom he knows or has reasonable grounds for supposing to be person who is about to commit or who has committed offence under this Act shall be guilty of offence under this Section.

SECTION 11 : "SEARCH WARRANTS"

If a presidency Magistrate, Magistrate First Class or Sub-Divisional magistrate is satisfied with the information that there is reasonable ground for suspecting that an offence under this Act has been or is about to be committed, he may grant search warrant to any Police Officer to enter at any time any premises to force to search premises or the places.

ENCLOSURE TO MDL Tender No:	
Name of Bidder:	
Address:	
Contact Number:	
email id:	
Details of Authorised Representatives; (Three Levels)	
1	Name: <input type="text"/>
	Designation <input type="text"/>
	Direct Landline Number: <input type="text"/>
	Mobile Number: <input type="text"/>
	Email id: <input type="text"/>
2	Name: <input type="text"/>
	Designation <input type="text"/>
	Direct Landline Number: <input type="text"/>
	Mobile Number: <input type="text"/>
	Email id: <input type="text"/>
3	Name: <input type="text"/>
	Designation <input type="text"/>
	Direct Landline Number: <input type="text"/>
	Mobile Number: <input type="text"/>
	Email id: <input type="text"/>

PROFORMA BANK GUARANTEE FOR BID BOND / EMD

(On Non-Judicial stamp paper of value Rs. 500/-. However, the value of stamp paper to be confirmed from Legal Department, MDL.)

IN CONSIDERATION OF MAZAGON DOCK SHIPBUILDERS LIMITED, a company incorporated under the Companies Act 1956 and having its registered office at Dockyard Road, Mumbai 400010 (hereinafter referred to as the "the Company" which expression shall, unless it be repugnant or contrary to the subject or context thereof, be deemed to mean and include its successors and assigns) having agreed to accept the Earnest Money Deposit (EMD) of Rs------(Rupees-----only) in the form of Bank Guarantee from Messers a partnership firm/sole proprietor business/a company registered under the Companies Act, 1956 having its office at(hereinafter called " the tenderer" which expression shall, unless it be repugnant or contrary to the subject or context thereof, be deemed to mean and include its successors and assigns) for participating in the Tender no.....dated..... (hereinafter called "the tender" which expression shall include any amendments/alterations to "the tender" issued by "the Company") for the supply, delivery at site, installation and commissioning of certain equipment, item/services/civil works etc., We, Bank having office at (hereinafter referred to as "the Bank" which expression shall include its successors and assigns) hereby agree to pay to the Company without any demur on first demand an amount not exceeding Rs..... (Rupees.....only) against any loss or damage, costs, charges and expenses caused to or suffered by the Company by reason of non performance and non-fulfilment or for any breach on the part of the tenderer of any of the terms and conditions of the said tender.

2. We, Bank further agree that the Company shall be sole judge whether the said tenderer has failed to perform or fulfil the said tender in terms thereof or committed breach of any terms and conditions of the tender the extent of loss, damage, cost, charges and expenses suffered or incurred or would be suffered or incurred by the Company on account thereof and we waive in the favour of the Company all the rights and defences to which we as guarantors may be entitled to.

3. We, Bank further agree that the amount demanded by the Company as such shall be final and binding on the Bank as to the Bank 's liability to pay and the amount demanded and the Bank undertake to pay the Company the amount so demanded on first demand and without any demur notwithstanding any dispute raised by the tenderer or any suit or other legal proceedings including arbitration pending before any court, tribunal or arbitrator relating thereto, our liability under this guarantee being absolute and unconditional.

4. We, Bank further agree with the Company that the Company shall have the fullest liberty without our consent and without affecting in any manner our obligations hereunder to vary any of the terms and conditions of the said tender/or to extend time of performance by the tenderer from time to time or to postpone for any time to time any of the powers exercisable by the Company against the tenderer and to forbear to enforce any of the terms and conditions relating to the tender and we shall not be relieved from our liability by reason of any such variation or extension being granted to the tenderer or for any forbearance, act or omission on the part of the Company or any indulgence by the Company to the tenderer or by any such matter or things whatsoever which under the law relating to sureties would have the effect of relieving us.

5. We, Bank further undertake not to revoke this guarantee during its currency except with the previous consent of the Company in writing.

6. We, Bank also agree that the Bank's liability under this guarantee shall not be affected by any change in the constitution of the tenderer or dissolution or winding up of the business of the tenderer.

7. Notwithstanding anything contained herein above:

- i) Our liability under this guarantee shall not exceed Rs.....
- ii) This Bank Guarantee shall be valid upto and including; and
- iii) We are liable to pay the guarantee amount or any part thereof under this Bank Guarantee only and only if you serve upon us a written claim or demand on or before(validity + ---weeks from the date of expiry of this guarantee).

8. This Guarantee shall be governed by Indian laws and the Courts at Mumbai, India shall have the exclusive jurisdiction.

IN WITNESS WHEREOF the Bank has executed this document on this..... day of

For Bank
(by its constituted attorney
or the person authorised to sign)

(Signature of a person authorised
to sign on behalf of "the Bank")

DECLARATION CERTIFICATE FOR LOCAL CONTENT
(Tender value Less than Rs 10 Crores)

This declaration must form part of all tenders & it contains general information and serves as a declaration form for all bidders. (Before completing this declaration, bidders must study the General Conditions, Definitions, Govt Directives applicable in respect of Local Content & prescribed tender conditions).

LOCAL CONTENT DECLARATION BY CHIEF FINANCIAL OFFICER OR OTHER LEGALLY RESPONSIBLE PERSON NOMINATED IN WRITING BY THE CHIEF EXECUTIVE OR SENIOR MEMBER/PERSON WITH MANAGEMENT RESPONSIBILITY (CORPORATION, PARTNERSHIP OR INDIVIDUAL)

IN RESPECT OF BID / TENDER No.
ISSUED BY: (Name of Firm):.....

NB: The obligation to complete, duly sign and submit this declaration cannot be transferred to an external authorized representative, auditor or any other third party acting on behalf of the bidder.

I, the undersigned, (full names),
do hereby declare, in my capacity as
of(name of bidder
entity), the following:

(a) The facts contained herein are within my own personal knowledge.

(b) I have read and understood the requirement of local content (LC) and same is specified as percentage calculated in accordance with the definition provided at clause 2 of revised Public Procurement (preference to Make in India) Order 2017.

"Local content" as per above order means the amount of value added in India which shall be the total value of items procured (excluding net domestic indirect taxes) minus the value of imported content in the item (including all customs duties) as a proportion of the total value in percent."

(c) I have satisfied myself that the goods/services/works to be delivered in terms of the above-specified bid comply with the local content requirements as specified in the tender for 'Class-I Local Supplier' / 'Class-II Local Supplier', and as above.

(d) I understand that a bidder can seek benefit of either Public Procurement Policy for MSEs –Order 2012 or Public Procurement (preference to Make in India) Order 2017 and not both and once the option is declared / selected it is not permitted to be modified subsequently. Accordingly, I seek the benefit from the below declared purchase preference policy only.

i) I seek benefits against the following policy only

1) PPP MSE Order 2012 (applicable for MSE manufacturers)

2) PPP MII 2017 (applicable for Class I suppliers as well as MSE manufacturers)

(e) The local content calculated using the definition given above are as under:

Tender Item Sr No	Local content calculated as above %	Location of local value addition

Attach separate sheet duly signed if space is not sufficient

NB: Local content percentage shall be declared item wise or tender wise strictly as per the terms of the tender.

(f) I accept that the Procurement Authority / Institution / MDL / Nodal Ministry has the right to request that the local content be verified in terms of the requirements of revised Public Procurement (preference to Make in India) Order 2017 dtd 16.09.2020 and I shall furnish the document / information on demand. Failure on my part to furnish the data will be treated as false declaration as per PPP MII Order 2017. In case of contract being awarded, I undertake to retain the relevant documents for 7 years from date of execution.

(g) I understand that the submission of incorrect data, or data that are not verifiable as described in revised Public Procurement (preference to Make in India) Order 2017, may result in the Procurement Authority / Nodal Ministry / MDL imposing any or all of the remedies as provided for in Clause 9 of the Revised Public Procurement (preference to Make in India) Order 2017 dated 16.09.2020

SIGNATURE: _____

DATE: _____

Seal / Stamp of Bidder

Declaration of Compliance of Order (Public Procurement No.1, 2 & 3) dtd 23 Jul 2020 & 24 Jul 2020 on Restrictions under Rule 144 (xi) of the General Financial Rules (GFRs), 2017

Before completing this declaration, bidders must study the General Conditions, Definitions, Govt. Directives applicable in respect of Public Procurement No.1, 2 & 3) dtd 23 Jul 2020 & 24 Jul 2020 on Restrictions under Rule 144 (xi) of the General Financial Rules (GFRs), 2017& prescribed tender conditions).

DECLARATION BY AUTHORISED SIGNATORY OF THE FIRM

I, the undersigned, (full names),
do hereby declare, in my capacity as
of M/s(name of bidder entity), that:

- 1) The facts contained herein are within my own personal knowledge.
- 2) I have read the Order (Public Procurement No.1, 2 & 3) dtd 23 Jul 2020 & 24 Jul 2020 on the subject of Restrictions under Rule 144 (xi) of the General Financial Rules (GFRs), 2017 regarding restrictions on procurement from a bidder of a country which shares a land border with India and comply to all the provisions of the Order
- 3) I certify that M/s(name of bidder entity) **is not from such a country / is from such a country and registered with the Competent Authority (strike out whichever is not applicable).** I hereby certify that this SUPPLIER fulfills all requirements in this regard and is eligible to be considered. [Where applicable, evidence of valid registration by the Competent Authority is attached]
- 4) I understand that the submission of incorrect data and / or if certificate / declaration given by M/s(name of bidder entity) is found to be false, this would be a ground for immediate termination and further legal action in accordance with law as per Clause 12 of the Public Order on Restrictions under Rule 144 (xi) of the General Financial Rules (GFRs), 2017

AUTHORISED SIGNATURE: _____ **DATE:** _____

Seal / Stamp of Bidder