

| | | | | |
|---|---|---|----------------------|---|
|  | NIRDESH Kozhikode, Kerala-673301 | PROPULSION SHAFT LINE DESIGN EVALUATION AND ALIGNMENT CALCULATIONS | Tender No. & date | NIRDESH/TENDER/03 Dated 25.01.2024 |
| | | | Closing Date | 15.02.2024 (1500HRS) |
| | | | Opening Date | 16.02.2024 (1530HRS) |
| | | | PAGE | 1 of 32 |

TENDER
FOR
R&D PROJECT

PROPULSION SHAFT LINE DESIGN
EVALUATION AND ALIGNMENT CALCULATIONS

**National Institute of Research and Development in Defence
Shipbuilding
(NIRDESH)
Kozhikode, Kerala - 673301**



| | | | | |
|---|---|--|-------------------|---------------------------------------|
|  | NIRDESH Kozhikode, Kerala-673301 | PROPULSION SHAFT LINE DESIGN EVALUATION AND ALIGNMENT CALCULATIONS | Tender No. & date | NIRDESH/TENDER/03 Dated 25.01.2024 |
| | | | Closing Date | 15.02.2024 (1500HRS) |
| | | | Opening Date | 16.02.2024 (1530HRS) |
| | | | PAGE | 2 of 32 |

TABLE OF CONTENTS

| SR. NO. | DESCRIPTION | PAGE NO. |
|---------|--|----------|
| 1. | INTRODUCTION | 4 |
| 2. | SCOPE OF ASSOCIATION | 4 |
| 3. | ELIGIBILITY TO BID | 4 |
| 4. | OBJECTIVE | 5 |
| 5. | SCOPE OF WORK(TECHNICAL REQUIREMENT) | 5 |
| 6. | APPLICABLE STANDARDS | 6 |
| 7. | REFERENCE | 6 |
| 8. | OVERVIEW OF THE SCOPE OF WORK | 7 |
| 9. | DELIVERABLES & TIMELINES | 8 |
| 10. | REVIEW MEETING | 8 |
| 11. | BID REJECTION CRITERIA | 8 |
| 12. | BID VALIDITY | 9 |
| 13. | SUBMISSION OF BIDS IN TWO-BID SYSTEM | 9 |
| 14. | PERFORMANCE BANK GUARANTEE | 10 |
| 15. | PRICING | 11 |
| 16. | RANKING OF BIDS & DETERMINATION OF L1 BIDDER | 11 |
| 17. | TAXES | 12 |
| 18. | PAYMENT MODALITIES | 12 |
| 19. | CERTIFYING AUTHORITY | 12 |
| 20. | PAYMENT TERMS | 12 |
| 21. | RESCINDMENT OF CONTRACT | 13 |
| 22. | INSOLVENCY & BREACH OF CONTRACT | 13 |
| 23. | FORCE MAJEURE CLAUSE | 13 |
| 24. | INTELLECTUAL PROPERTY RIGHTS(IPR) | 14 |
| 25. | SECURITY OF INFORMATION/ NDA | 14 |
| 26. | ASSIGNMENT & SUB CONTRACTING | 14 |
| 27. | ARBITRATION | 14 |
| 28. | CONFLICT OF INTEREST AMONG BIDDERS/ AGENTS | 15 |
| 29. | POINT OF CONTACT | 16 |

| | | | | |
|---|---|--|-------------------|---------------------------------------|
|  | NIRDESH Kozhikode, Kerala-673301 | PROPULSION SHAFT LINE DESIGN EVALUATION AND ALIGNMENT CALCULATIONS | Tender No. & date | NIRDESH/TENDER/03 Dated 25.01.2024 |
| | | | Closing Date | 15.02.2024 (1500HRS) |
| | | | Opening Date | 16.02.2024 (1530HRS) |
| | | | PAGE | 3 of 32 |

| ANNEXURE | DESCRIPTION | PAGE NO. |
|----------|---|----------|
| ANNEX: A | ILLUSTRATIVE RATE SHEET FORMAT | 17 |
| ANNEX: B | GST DECLARATION | 18 |
| ANNEX: C | TENDER ACCEPTANCE FORM | 19 |
| ANNEX: D | GENERAL CONDITIONS OF CONTRACT | 20 |
| ANNEX: E | GENERAL CONDITIONS OF CONTRACT ACCEPTANCE FORMAT | 30 |
| ANNEX: F | DECLARATION OF BIDDER REGARDING CONFLICT OF INTEREST AMONG BIDDERS/ AGENTS | 31 |
| ANNEX: G | PRELIMINARY ARRANGEMENT DRAWING FOR SHAFTING | 32 |

| | | | | |
|---|---|--|-------------------|---------------------------------------|
|  | NIRDESH Kozhikode, Kerala-673301 | PROPULSION SHAFT LINE DESIGN EVALUATION AND ALIGNMENT CALCULATIONS | Tender No. & date | NIRDESH/TENDER/03 Dated 25.01.2024 |
| | | | Closing Date | 15.02.2024 (1500HRS) |
| | | | Opening Date | 16.02.2024 (1530HRS) |
| | | | PAGE | 4 of 32 |

1. **INTRODUCTION**

The project is being undertaken under NIRDESH for the WDB under Research & Development initiative of NIRDESH and intends to undertake Project on Propulsion Shaft line design, design evaluation and alignment calculations for all the existing and future Naval Platforms.

The aim of this 'Capability Enhancement Approach' is to develop capability to undertake the following with the use of analytical methods / globally accepted and certified software tools like Nauticus, ShaftDesigner etc. and Engineering Standards: -

(a) Detail Design of the Shaft line to arrive at the final shaft diameters over the entire length of the shaft line, bearing locations etc.

(b) Modelling of the shaft line using proven and established software and in accordance with established global engineering practices / standards to carryout Alignment Calculations under different conditions of loading / hull deflection, specification of shaft alignment parameters like Gap-Sag values, finalisation of optimal Bearing offsets and Load Distribution, analysis of shaft deflection / slope / bending moment / shear stress / bearing pressure distribution etc.

2. **SCOPE OF ASSOCIATION**

NIRDESH is seeking response from eligible Indian startup firms willing to collaborate for undertaking Research & Development projects by deputing their engineers in Centre of Excellence (CoE) of NIRDESH, which is residing inside premises of Mazagon Dock Shipbuilders Ltd, Mumbai. Working environment will be provided in the CoE.

3. **ELIGIBILITY TO BID**

Definition of Indian Startup Firm:

- a) An Indian startup firm, an Indian entity including incorporation/ ownership models as per the Companies Act, 2013 , Partnership Firm, Proprietorship and other types of ownership models including Societies as per relevant laws, complying with, besides other regulations in force, and the guidelines/licensing requirements stipulated by the DPIIT/Government of India.
- b) The firm must be willing to depute their manpower in Centre of Excellence (CoE) of NIRDESH which is residing inside premises of Mazagon Dock Shipbuilders Ltd, Mumbai. Working environment as required, will be provided in the CoE by NIRDESH.
- c) The firm should NOT be older than 10 years from the date of incorporation.

| | | | | |
|---|---|--|-------------------|---------------------------------------|
|  | NIRDESH Kozhikode, Kerala-673301 | PROPULSION SHAFT LINE DESIGN EVALUATION AND ALIGNMENT CALCULATIONS | Tender No. & date | NIRDESH/TENDER/03 Dated 25.01.2024 |
| | | | Closing Date | 15.02.2024 (1500HRS) |
| | | | Opening Date | 16.02.2024 (1530HRS) |
| | | | PAGE | 5 of 32 |

- d) The firm should have an annual turnover NOT exceeding 100 Crores(INR) in any of the financial years since incorporation.
- e) The participating firm must possess necessary knowledge of the field of collaboration and should be working towards innovation / development / improve of products and services.
- f) The relevant technology if any possessed by participating firm must be non-infringing while delivering the desired performance and it must be clear from third-party IP infringement claims.

4. **OBJECTIVE**

Based on concept design inputs, the shaft line general arrangement and associated calculations are undertaken at WDB in accordance with DEF STAN 304, shafting standards and model test data, which is part of 'Functional Design Study'. Subsequently, Functional Design details are collated in Shafting procurement specification and forwarded to potential supplier. Potential supplier undertakes 'Detail Design Study' pertaining to the shaft line based on Functional Design inputs. A number of studies / design aspects are actually undertaken through foreign OEMs due to lack of expertise within the country. Keeping in line with the spirit of Atmanirbhar Bharat and Make in India philosophies of the GoI, there is a need to reduce dependence on foreign OEMs and develop the capability in India. Accordingly, capability enhancement needs to be undertaken to be able to undertake Detail Design including Alignment Calculations of Propulsion Shaft line of warships within WDB / Indian Shipyards.

In case of any technical issue with existing shaft line of commissioned Naval Platforms, WDB requires to undertake "Causative Analysis Study" to analyse the problem and provide the solution. However, in present circumstances capability for the same is not adequate. This also requires capability enhancement.

5. **SCOPE OF WORK (TECHNICAL REQUIREMENT)**

The scope of work covers development of comprehensive methodology, guidelines, procedures, utility software applications / modules etc. including suitable documentation inclusive of published technical / research papers, reference standards, extracts from technical books, software manuals etc. to completely and comprehensively achieve the Aim stated at Para 1 above.

In addition, certification of the developed methodology/procedure/guidelines through IACS needs to be obtained and a study needs to be undertaken using the developed methodology / procedure for validation of an existing design for which minimum necessary data will be furnished.

| | | | | |
|---|---|--|-------------------|---------------------------------------|
|  | NIRDESH Kozhikode, Kerala-673301 | PROPULSION SHAFT LINE DESIGN EVALUATION AND ALIGNMENT CALCULATIONS | Tender No. & date | NIRDESH/TENDER/03 Dated 25.01.2024 |
| | | | Closing Date | 15.02.2024 (1500HRS) |
| | | | Opening Date | 16.02.2024 (1530HRS) |
| | | | PAGE | 6 of 32 |

The scope of work covers all necessary shaft line design evaluation and alignment calculations using hand calculations/ proven shaft analysis software. The shaft line analysis scope covers following aspects, and requires supportive documents and extensive study material like research papers and technical books in support:

- (a) Strength analysis of shaft line critical areas where discontinuity exists.
- (b) Bearing load analysis including bearing wear down conditions.
- (c) Hull deflection analysis.
- (d) Installation and alignment calculation and its analysis.

Guiding document/ Reference/standards (if any) used to develop methodology/procedure needs to be submitted as part of deliverables.

6. **APPLICABLE STANDARDS:**

Following standards / specifications or their equivalent International Standards as per their latest issues/versions shall be applicable.

| S No. | Standards/Specification | Title |
|-------|---------------------------------------|---|
| i. | Defence Standard 02-304 (Part 1 to 5) | Shafting system and propulsions |
| ii. | Defence Standard (NES) 1004 | Requirements for the design and testing of equipment to meet environmental conditions. |
| iii. | MIL-STD-1472G | Design criteria standard - Human engineering. |
| iv. | IN Shock grade 'A' | Requirements for high impact shock qualification, shipboard equipment and systems. |
| v. | MIL-S-901D | Shock tests, high impact shipboard machinery and systems. |
| vi. | MIL-STD-740-2 (SH) | Structure-borne vibratory acceleration measurements and acceptance criteria for ship board equipment. |
| vii. | MIL-STD-1474-E | Air borne sound measurements and acceptance criteria of shipboard equipment. |
| viii. | BS 1SO 3744 – 1994 | Acoustics-determination of sound power level of noise sources using sound pressure. |
| ix. | MIL-STD-167-1(A) | Mechanical vibrations of Shipboard equipment. |

7. **REFERENCE**

Maximum rated power of prime movers and maximum shaft speeds in Gas turbine and Diesel engine mode are mentioned below. **Below indicated parameters is for CODOG propulsion system configuration and for reference only.**

| | | | | |
|---|---|--|-------------------|---------------------------------------|
|  | NIRDESH Kozhikode, Kerala-673301 | PROPULSION SHAFT LINE DESIGN EVALUATION AND ALIGNMENT CALCULATIONS | Tender No. & date | NIRDESH/TENDER/03 Dated 25.01.2024 |
| | | | Closing Date | 15.02.2024 (1500HRS) |
| | | | Opening Date | 16.02.2024 (1530HRS) |
| | | | PAGE | 7 of 32 |

| <u>S No.</u> | <u>Mode of Operation</u> | <u>Maximum Rated Power (MW)</u> | <u>Prime mover Input Speed (RPM)</u> | <u>Maximum Output Shaft Speed (RPM)</u> |
|--------------|--------------------------|---------------------------------|--------------------------------------|---|
| (a) | Gas turbine | 22.37 | 3600 | Around 200 |
| (b) | Diesel engine | Appx. 5.4 | 1050 to 1250 | Around 125. |

Design evaluation and alignment calculations should not be limited to above system configuration only.

Various system configurations are as follow:

- a. COGAG
- b. CODAG
- c. CODAD
- d. CODOG
- e. CODELAG
- f. CODELOD etc.

Refer Annex: G for Preliminary arrangement drawing of shafting.

8. OVERVIEW OF THE SCOPE OF WORK

The task required for completion of the scope of work shall be carried out in three phases as follows:

| Phase | Description |
|-------|---|
| I | Developing a concept, methodology and approach for project execution |
| II | Execution of work as per specified scope and concept/ approach finalized in phase I |
| III | Certification and Validation |

Phase I: Developing a concept, methodology, mathematical model and approach for project execution.

The concept document shall cover minimum the following:

- a. Details of the methodologies/ mathematical model, techniques and approach in achieving the objectives indicated above.
- b. Any other relevant details considered necessary.

Phase II: Execution of work as per specified scope and concept/ approach finalized in Phase I.

| | | | | |
|---|---|--|-------------------|---------------------------------------|
|  | NIRDESH Kozhikode, Kerala-673301 | PROPULSION SHAFT LINE DESIGN EVALUATION AND ALIGNMENT CALCULATIONS | Tender No. & date | NIRDESH/TENDER/03 Dated 25.01.2024 |
| | | | Closing Date | 15.02.2024 (1500HRS) |
| | | | Opening Date | 16.02.2024 (1530HRS) |
| | | | PAGE | 8 of 32 |

Phase III: Certification and Validation of the developed methodology, guidelines, procedures, utility software applications/ modules etc. with real time data available with IN/ Shipyard for ongoing/ completed Warship projects.

9. **DELIVERABLES & TIMELINES:**

The task-wise list of deliverables and timelines for the tasks in two phases for the project execution with respect to the date of acceptance of the purchase order (D) shall be as follows:

| Task No. | Deliverable No. | Deliverables | Submission Format | Submission medium | Timeline (Months) |
|-----------------|-----------------|--|--------------------|----------------------------------|-------------------|
| Phase-I | | | | | |
| 1 | D1 | Preparation of a concept document | Documents/ Reports | Hard Copies -2 Nos and Soft copy | D+01 |
| Phase-II | | | | | |
| 2 | D2 | Comprehensive methodology, guidelines, procedures, utility software applications / modules etc. including suitable documentation inclusive of published technical / research papers, reference standards, extracts from technical books, software manuals etc. | Documents/ Reports | Hard Copies -2 Nos and Soft copy | D+6 |
| 3 | D3 | Certification through IACS and validation report. | Documents/ Reports | Hard Copies -2 Nos and Soft copy | D+7 |

Guiding document/ Reference/ standards used to develop methodology/procedure needs to be submitted as part of deliverables.

10. **REVIEW MEETING:**

NIRDESH will closely monitor the progress of the project. Weekly review meeting will be convened to that effect. Firm has to submit periodic progress reports. All hindrances with date of occurrences and removal shall be noted in the review meetings.

11. **BID REJECTION CRITERIA**

- a) Non-compliance/non-acceptance to any of the terms and conditions of the tender shall render the bid liable for rejection.

| | | | | |
|---|---|--|-------------------|---------------------------------------|
|  | NIRDESH Kozhikode, Kerala-673301 | PROPULSION SHAFT LINE DESIGN EVALUATION AND ALIGNMENT CALCULATIONS | Tender No. & date | NIRDESH/TENDER/03 Dated 25.01.2024 |
| | | | Closing Date | 15.02.2024 (1500HRS) |
| | | | Opening Date | 16.02.2024 (1530HRS) |
| | | | PAGE | 9 of 32 |

12. **BID VALIDITY:**

Bids /Offers shall have a validity period of 120 days from the tender closing date.

13. **SUBMISSION OF BIDS IN TWO-BID SYSTEM:**

- a) Offer/bids must be submitted in two parts, Part-I: Techno-commercial Bid & Part-II: Price Bid in two separate sealed envelopes clearly indicating Techno-Commercially Bid and Price Bid. Both the envelopes shall be kept together in a final envelope and submitted to MDL.
- b) Offers must be submitted in sealed envelopes super scribing:
 - i) Name of Bidder, ii) tender no., due date, & time and iii) Bid (Whether Techno-Commercially Bid or Price Bid).
- c) Envelope containing both offers (Techno-Commercially Bid and Price Bid separately), must be addressed to:

**General Manager, (Outsourcing),
6th floor, Service Block Building,
North Yard,
Mazagon Dock Shipbuilders Ltd.
Mumbai-400 010
Maharashtra.**
- d) The offer should be deposited in the tender box kept at Outsourcing department, 6th floor, Service Block, Mazagon Dock Shipbuilders Ltd. or should reach to the above address on or before tender closing time.
- e) **Part- I: Techno-commercial bid** shall contain the following:
 - i. **Technical Documents:** As per tender clause 3: **Eligibility to Bid.**
 - ii. **Annexure-A:** Clearly indicating “**Quoted**” or “**Not Quoted**” in the price field and mentioning the applicable **GST%** and **HSN/SAC** code. Please note that the actual prices to be submitted with Part-II Bid only.
 - iii. **Annexure-B:** Bidders should submit signed and stamped acceptance of GST Declaration (GST Terms & Conditions).
 - iv. **Annexures C & E:** Duly stamped, signed & filled ‘**Accepted OR Not Accepted**’ as applicable for each of the clause. Normally deviations to the tender terms are discouraged.
 - v. **Deviation Sheet:** If the bidder has any deviations under any clause of the tender or General Conditions of the Contract (Annexure-D), the same should be filled in **Annexures C & E** mentioning the deviation against the relevant Tender clause no., failing which it will be construed that all clauses of Tender inquiry appearing against the tender are understood by you and are fully acceptable to you. In the event bidder has no deviations, he should

| | | | | |
|---|---|--|-------------------|---------------------------------------|
|  | NIRDESH Kozhikode, Kerala-673301 | PROPULSION SHAFT LINE DESIGN EVALUATION AND ALIGNMENT CALCULATIONS | Tender No. & date | NIRDESH/TENDER/03 Dated 25.01.2024 |
| | | | Closing Date | 15.02.2024 (1500HRS) |
| | | | Opening Date | 16.02.2024 (1530HRS) |
| | | | PAGE | 10 of 32 |

submit following forms mentioning 'Accepted'. Any deviations mentioned elsewhere in the offer other than in said Forms will not be considered.

- vi. **Annexure-F:** Declaration by Bidder Regarding Conflict of Interest among Bidders/ Agents.
- vii. GST Registration Certificate.
- viii. UDYAM Registration Certificate if applicable.
- ix. Copy of PAN card.
- x. Company Profile, Shop & Establishment and Tax registration certificate.

Note: Bidders in their own interest are requested to submit their bids well in advance of tender closing date to avoid the last minute difficulties.

- f) **Part- II (Price Bid):** This should contain only the PRICES for each of the listed items strictly in the prescribed format (**Annexure-A**). Price bid must be enclosed only in the required format as provided.

Note: In case of error in the aggregate values, the individual service-wise quoted rates will be considered.

Along with prices for the tendered services/ Items, applicable Taxes & duties and HSN/SAC are also to be quoted in the rate sheet. Timely submission of the offer/bids is responsibility of the bidders and no reasons / excuses in this regard will be entertained.

- g) Opening of Techno-Commercial Bid (Part-I): Techno-Commercial bid (Part-I) will be opened on the tender opening date or extended tender opening date or next working day if opening date happens to be holiday declared by MDL.
- h) Opening of Price Bid (Part-II): After completion of Techno-commercial scrutiny, intimation for price bid opening will be communicated only to techno-commercially accepted bidders. Bidder (s) to note that such intimation may be given at a short notice by Fax, E-mail or even by telephone only to techno-commercially accepted bidder(s).

14. **PERFORMANCE BANK GUARANTEE**

- a) Performance Bank Guarantee (PBG) shall be in the name of NIRDESH, Kozhikode. It will be equivalent to 5% of the contract value.
- b) Performance Bank Guarantee (PBG) to be submitted in the form of NEFT / DD/ Pay Order/ Bank Guarantee drawn in favor of NIRDESH from the list of

| | | | | |
|---|---|--|-------------------|---------------------------------------|
|  | NIRDESH Kozhikode, Kerala-673301 | PROPULSION SHAFT LINE DESIGN EVALUATION AND ALIGNMENT CALCULATIONS | Tender No. & date | NIRDESH/TENDER/03 Dated 25.01.2024 |
| | | | Closing Date | 15.02.2024 (1500HRS) |
| | | | Opening Date | 16.02.2024 (1530HRS) |
| | | | PAGE | 11 of 32 |

banks approved by SBI/ Canara bank published on MDL website within 25 days from the date of contract.

- c) The BG should be valid up to 6 weeks beyond the end of the contractual / completion / Order validity period.
- d) In case the completion of work is likely to be delayed beyond the Order completion period/Contractual period or this period is required to be extended, the Contractor shall have to extend the validity of the Bank Guarantee for PBG till such extended period.
- e) Non-performance of the Terms & conditions of Order and/or default/breach by the Contractor will result in forfeiture of the PBG.
- f) The PBG will be returned /refunded to the Contractor, without interest, on successful execution of the Order.
- g) The developed methodology, guidelines, procedures, utility software applications / modules etc. including suitable documentation should be guaranteed for comprehensiveness, correctness and utility towards achieving the aims listed at Para 1 above. The firm shall ensure complete responsibility and accountability towards the same. In case of errors / ambiguities / doubts / lack of clarity or details observed during use, the firm is bound to rectify it free of cost / forfeit the right to be considered for technical studies by IN/ Shipyard.

15. **PRICING:**

- a) Firms will be qualified based of their technical capabilities, Compliance to the terms ibid and submitted quote.
- b) The contract prices will be firm and fixed as per contract terms till execution of contract.
- c) Bidders shall quote the prices along with applicable Duties, Taxes and Levies and shall ensure compliance during the execution of the contract.
- d) No increases in price on account of any statutory increase in or fresh Imposition of GST, customs duty or on account of any other taxes/ duty/ cess/ levy), leviable in respect of the Services stipulated which takes place after the original delivery date or any extension thereof granted by NIRDESH for which the delay is attributable to the bidder, shall be admissible.
- e) Firm needs to submit a compliance to all clauses in the tender.

16. **RANKING OF BIDS & DETERMINATION OF L-1 BIDDER**

Techno-commercially qualified overall lowest bidder will be considered for the placement of order. Taxes, duties and levis are excluded for the purpose of ranking of price bids to determine L1 bidder.

| | | | | |
|---|---|--|-------------------|---------------------------------------|
|  | NIRDESH Kozhikode, Kerala-673301 | PROPULSION SHAFT LINE DESIGN EVALUATION AND ALIGNMENT CALCULATIONS | Tender No. & date | NIRDESH/TENDER/03 Dated 25.01.2024 |
| | | | Closing Date | 15.02.2024 (1500HRS) |
| | | | Opening Date | 16.02.2024 (1530HRS) |
| | | | PAGE | 12 of 32 |

17. **TAXES:**

- a) The items/service-wise rates quoted in the Rate sheet should exclude Taxes and Duties. Bidder should indicate Taxes and Duties as applicable separately in the same Rate sheet, at the space provided for, which will be paid extra based on tax invoice to the extent applicable.
- b) The variation in statutory levies etc. are not allowed unless the breakups in respect of taxes duties are clearly and separately furnished in bid.
- c) Bidders are required to submit their provisional ID with HSN number, along with documentary proof. NIRDESH's provisional GST ID is 27AAACM8029J1ZA.
- d) Bidders are required to comply with all the provisions applicable under the GST Act. (Please refer Annexure-B)

18. **PAYMENT MODALITIES**

| Sr. No. | Stage | Percentage of the contract value |
|---------|---|----------------------------------|
| 1 | Satisfactory completion of Deliverable # 01 | 40% |
| 2 | Satisfactory completion of Deliverable # 02 | 55% |
| 3 | Satisfactory completion of Deliverable # 03 | 5% |

19. **CERTIFYING AUTHORITY**

The deliverable submitted by the firm/start-up/ shall be certified by WDB Navy in twenty (20) working days based on certification by a suitable IACS agency. Thereafter, MDL/NIRDESH shall issue a work completion certificate for release of the payment.

20. **PAYMENT TERMS:**

- a) No Advance will be paid in any manner against the contract.
- b) 100% payment will be made through RTGS/NEFT within 15 days for satisfactory completion of each task and on submission of set of Original + 2 copies of ink signed monthly Tax Invoice along with Work Completion Certificate.
- c) The invoices should be preferably submitted within four weeks of certification of Work Completion Certificate 'WCC' to NIRDESH.
- d) In case of delay, not attributable to NIRDESH, such delay shall be certified in the WCC to invoke LD clause and to effect recoveries from contractor's invoice

| | | | | |
|---|---|--|-------------------|---------------------------------------|
|  | NIRDESH Kozhikode, Kerala-673301 | PROPULSION SHAFT LINE DESIGN EVALUATION AND ALIGNMENT CALCULATIONS | Tender No. & date | NIRDESH/TENDER/03 Dated 25.01.2024 |
| | | | Closing Date | 15.02.2024 (1500HRS) |
| | | | Opening Date | 16.02.2024 (1530HRS) |
| | | | PAGE | 13 of 32 |

21. **RESCINDMENT OF CONTRACT**

If at any stage during the work, the firm ceases work or refuses to fulfil his part of the contract, the NIRDESH shall have power to rescind the contract, of which rescission notice in writing to Firm under the hand of the NIRDESH shall be conclusive evidence of firms default and the whole of the Performance Bank Guarantee paid by Contractor(s) shall stand forfeited and be absolutely at the disposal of NIRDESH.

22. **INSOLVENCY AND BREACH OF CONTRACT**

- a) NIRDESH may at any time by notice in writing summarily terminate the contract without compensation to the firm in any of the following events-
- b) If Firm being an individual or if a firm any partner shall at any time be adjudged insolvent or shall have a receiving order or order for administration of his estate made against him or shall take any proceedings for liquidation or for Composition under any Insolvency Act for the same being in force or make any conveyance or assignment of his effects or enter into any arrangement with these creditors or suspend payment or if the firm be dissolved under the Partnership Act; or
- c) If the firm being a company shall pass a resolution or the court shall make an order for the liquidation of its affairs or a Receiver or Manager on behalf of the debenture holders shall be appointed or circumstances shall have arisen which entitled the court or debenture-holders to appoint a Receiver or Manager; or If the firm commits any breach of this Contract not being specifically herein provided for; provided always that such determination shall not prejudice any right of action or remedy which shall have accrued or shall accrue thereafter to NIRDESH and provided also that firm shall be liable to pay NIRDESH for any extra expenditure they are hereby put up.

23. **FORCE MAJEURE CLAUSE**

On the occurrence of any unforeseen event, beyond the control of either Party, directly interfering with the delivery of Services arising during the currency of the contract, such as war, hostilities, acts of the public enemy, civil commotion, sabotage, fires, floods, explosions, epidemics, quarantine restrictions, strikes, lockouts, or acts of God, the affected Party shall, within a week from the commencement thereof, notify the same in writing to the other Party with reasonable evidence thereof. Unless otherwise directed by NIRDESH in writing, the bidder shall continue to perform its obligations under the contract as far as reasonably practicable and shall seek all reasonable alternative means for performance not prevented by the Force Majeure event. If the force majeure condition(s) mentioned above be in force for 90 days or more at any time, either

| | | | | |
|---|---|--|-------------------|---------------------------------------|
|  | NIRDESH Kozhikode, Kerala-673301 | PROPULSION SHAFT LINE DESIGN EVALUATION AND ALIGNMENT CALCULATIONS | Tender No. & date | NIRDESH/TENDER/03 Dated 25.01.2024 |
| | | | Closing Date | 15.02.2024 (1500HRS) |
| | | | Opening Date | 16.02.2024 (1530HRS) |
| | | | PAGE | 14 of 32 |

party shall have the option to foreclose the contract on expiry of 90 days of commencement of such force majeure by giving 14 days' notice to the other party in writing.

24. **INTELLECTUAL PROPERTY RIGHTS (IPR)**

NIRDESH/MDL intends to develop a methodology on propulsion plant vibrational analysis to evaluate torsional, longitudinal and lateral vibrations on a complete propulsion train. The bidding firm must be willing to transfer all intellectual property rights to IHQ/WDB and MDL. The bidder must submit a detailed proposal towards approaching this objective in their technical offer.

25. **SECURITY OF INFORMATION / NDA (Non-Disclosure Agreement)**

The Bidder / Contractor shall hold confidential technical data and information supplied by NIRDESH and shall not reproduce any such technical data or information or divulge the same to any third party without the prior written consent of NIRDESH. Successful bidders to execute a NDA having a period of confidentiality in perpetuity after winning the contract. All information & inputs provided by NIRDESH shall be treated as confidential and shall not be shared with any agency without the prior approval of NIRDESH.

26. **ASSIGNMENT & SUB CONTRACTING**

- a) The bidder shall not, save with the previous consent in writing from NIRDESH, sublet, transfer, or assign the contract or any part thereof or interest therein or benefit or advantage thereof in any manner whatsoever.
- b) The bidder shall notify NIRDESH in writing all subcontracts awarded under the contract if not already stipulated in the contract. In its original bid or later, such notification shall not relieve the contractor from any of its liability or obligation under the terms and conditions of the contract. Subcontracts must comply with and should not circumvent Contractor's compliance with its obligations, based on which the contract was awarded to him.

27. **ARBITRATION**

Unresolved disputes/differences, if any, shall then be settled by arbitration. The Arbitration proceedings shall be conducted at Mumbai, India, in English Language, under the Arbitration & Conciliation Act, 1996.

| | | | | |
|---|---|--|-------------------|---------------------------------------|
|  | NIRDESH Kozhikode, Kerala-673301 | PROPULSION SHAFT LINE DESIGN EVALUATION AND ALIGNMENT CALCULATIONS | Tender No. & date | NIRDESH/TENDER/03 Dated 25.01.2024 |
| | | | Closing Date | 15.02.2024 (1500HRS) |
| | | | Opening Date | 16.02.2024 (1530HRS) |
| | | | PAGE | 15 of 32 |

28. **CONFLICT OF INTEREST AMONG BIDDERS/ AGENTS**

Conflict of Interest among Bidders/ Agents A bidder shall not have conflict of interest with other bidders. Such conflict of interest can lead to anticompertitive practices to the detriment of NIRDESH's interests. The bidder found to have a conflict of interest shall be disqualified. A bidder may be considered to have a conflict of interest with one or more parties in this bidding process, if:

- a) they have controlling partner (s) in common; or
- b) they receive or have received any direct or indirect subsidy/ financial stake from any of them; or
- c) they have the same legal representative/agent for purposes of this bid; or
- d) they have relationship with each other, directly or through common third parties, that puts them in a position to have access to information about or influence on the bid of another Bidder; or
- e) Bidder participates in more than one bid in this bidding process. Participation by a Bidder in more than one Bid will result in the disqualification of all bids in which the parties are involved. However, this does not limit the inclusion of the components/ sub-assembly/ Assemblies from one bidding manufacturer in more than one bid.
- f) In cases of agents quoting in offshore procurements, on behalf of their principal manufacturers, one agent cannot represent two manufacturers or quote on their behalf in a particular tender enquiry. One manufacturer can also authorise only one agent/dealer. There can be only one bid from the following:
 - i. The principal manufacturer directly or through one Indian agent on his behalf; and
 - ii. Indian/foreign agent on behalf of only one principal.
- g) A Bidder or any of its affiliates participated as a consultant in the preparation of the design or technical specifications of the contract that is the subject of the Bid;
- h) In case of a holding company having more than one independently manufacturing units, or more than one unit having common business ownership/management, only one unit should quote. Similar restrictions would apply to closely related sister companies. Bidders must proactively declare such sister/ common business/ management units in same/ similar line of business.

| | | | | |
|---|---|---|-------------------|---|
|  | NIRDESH Kozhikode, Kerala-673301 | PROPULSION SHAFT LINE DESIGN EVALUATION AND ALIGNMENT CALCULATIONS | Tender No. & date | NIRDESH/TENDER/03 Dated 25.01.2024 |
| | | | Closing Date | 15.02.2024 (1500HRS) |
| | | | Opening Date | 16.02.2024 (1530HRS) |
| | | | PAGE | 16 of 32 |

29. **POINT OF CONTACT**

For Technical Clarification

Mr. P Dhanaraj
GM /HOD (Design)
Tel: (91) 022-23738152
Fax: (91)022-23738159
E-mail: pdhanaraj@mazdock.com

AND

Mr. C M Vishwakarma
AGM/HOS (Design – Engg)
Tel: (91) 022-23733040
Fax: (91)022-23738159
E-mail: cmvishwakarma@mazdock.com

For Commercial Clarification:

Mr. Navneet Kumar
DM(OTS-YS)
✉ navneetkumar@mazdock.com
☎ +91-22 2376 3442.

| | | | | |
|---|---|--|-------------------|---------------------------------------|
|  | NIRDESH Kozhikode, Kerala-673301 | PROPULSION SHAFT LINE DESIGN EVALUATION AND ALIGNMENT CALCULATIONS | Tender No. & date | NIRDESH/TENDER/03 Dated 25.01.2024 |
| | | | Closing Date | 15.02.2024 (1500HRS) |
| | | | Opening Date | 16.02.2024 (1530HRS) |
| | | | PAGE | 17 of 32 |

Annexure-A: ILLUSTRATIVE RATE SHEET FORMAT

| Sr. | Description | Qty | Unit Rate | Total Value | GST% | HSN/SAC |
|-------|---------------------------------------|------|-----------|-------------|------|---------|
| 1 | PROPULSION PLANT VIBRATIONAL ANALYSIS | 1 AU | | | | |
| Total | | | | | | |

COMPANY'S NAME & ADDRESS:

SIGNATURE:

DATE:

NAME:

DESIGNATION:

BIDDER'S COMPANY SEAL:

CONTACT NO.

EMAIL ID:

NOTE:

- i) This rate sheet is only for illustration purpose & for the purpose of indicating tax and whether **quoted / not quoted** and submitted the same with Part-I – Technical Bid
- ii) **Actual prices are to be submitted in this format with Part-II – Price Bid.**
- iii) Bidder while quoting should consider all costs such as labour, hike in the minimum wages, transportation, equipment, all incidental expenses, consumables etc.
- iv) Quantity shown is indicative. However, Payment shall be made as per actual work done.
- v) An **illustrative example** of blank rate sheet to be submitted with Part I – Technical bid is given below:

Illustrative Example of Blank rate sheet to be uploaded in Part-I.

| Sl. No. | Item Description | Quantity | Units | Units Rate | Total | Type of Applicable Tax | Applicable Tax in Percentage | HSN Code |
|---------|---------------------------------------|----------|-------|------------|--------|------------------------|------------------------------|----------|
| 1 | PROPULSION PLANT VIBRATIONAL ANALYSIS | 1 | AU | Quoted | Quoted | XY | AB% | 123456 |
| Total | | | | | Quoted | | | |

| | | | | |
|---|---|--|-------------------|---------------------------------------|
|  | NIRDESH Kozhikode, Kerala-673301 | PROPULSION SHAFT LINE DESIGN EVALUATION AND ALIGNMENT CALCULATIONS | Tender No. & date | NIRDESH/TENDER/03 Dated 25.01.2024 |
| | | | Closing Date | 15.02.2024 (1500HRS) |
| | | | Opening Date | 16.02.2024 (1530HRS) |
| | | | PAGE | 18 of 32 |

Annexure-B: GST DECLARATION

1. GST as per GST Laws shall be payable extra as quoted and agreed.
2. In case of purchases of goods/services from unregistered dealers under GST Laws, GST will be paid by NIRDESH under reverse charge mechanism.
3. Benefits from reduction in rate of tax/ITC are required to be passed on to consumer. Where “applicable GST” has been quoted as extra, Goods and service providers (except un-registered dealers under GST Law) have to submit declaration that they have complied with ‘Anti-profiteering clause’ under GST Law. . Such declaration be given in technical bid.
4. If the vendor is registered under GST, vendor shall mention the HSN code for goods &/or services in their tax invoice, etc. These codes must be in accordance with GST Laws and responsibility of specifying correct HSN codes for goods &/or services is that of the vendor. NIRDESH shall not be responsible for any error in HSN code for goods &/or services specified by supplier / contractor. Supplier /Contractor shall pay penalty and/ or interest imposed on NIRDESH or any loss due to delay in availing ITC by NIRDESH or any loss of ITC to NIRDESH due to errors by vendors at any stage. NIRDESH reserves right to recover any such interest, penalty or loss from any amount due to Supplier /Contractor or otherwise.
5. In case, NIRDESH is unable to avail ITC, supplier/contractor at their own cost shall rectify the shortcoming in the returns to be filed immediately thereafter. Further, if the ITC is delayed / denied to NIRDESH / reversed subsequently as per GST Laws due to non / delayed receipt of goods and / or services and / or tax invoice or expiry of timelines prescribed in GST Laws for availing ITC, non-payment of taxes or non-filing of returns or any other reason not attributable to NIRDESH, Supplier /Contractor shall pay any loss of amount along with interest and penalty on NIRDESH under GST Laws for the number of days the ITC was delayed. If the short coming is not rectified by supplier/contractor and NIRDESH ends up in reversal of credits and / or payments, supplier /contractor is fully liable for making good all the loss incurred by NIRDESH. NIRDESH reserves right to recover any interest, penalty or loss from any amount due to Supplier /Contractor or otherwise.
6. If the vendor is registered under GST, the GST registration number (15 digit GSTIN) issued by GOI shall be mandatorily provided by the vendor. Vendor having multiple business verticals within state / at multiple states with separate GST registration numbers shall forward GSTIN of only that vertical which is involved in supply of goods and/or services. NIRDESH GSTIN is 32AABAN0245L1ZV and vendor shall mention the same while invoicing and avoid any data entry error on GST portal.
7. If the vendor is registered under GST, Vendor shall ensure timely submission of invoice as per the provisions / requirement / timeline promulgated by GOI in relation to GST Law with all required supporting documents to enable NIRDESH to avail input tax credit promptly. The vendors invoice inter alia should contain GSTIN of vendor, GSTIN of NIRDESH (i.e. 32AABAN0245L1ZV), GST tax rate separately, HSN code wise goods or services, place of supply, signature of vendor, etc. Original invoice needs to be submitted to Bill Receipt Centre at NIRDESH gate, and a copy of the invoice should be given to the goods receiving section(GRS).
8. If the vendor is registered under GST, vendor shall file all applicable returns under GST Laws in the stipulated time & any losses of tax credit to NIRDESH arising due to delay in filing will be recovered from their invoice wherever NIRDESH is eligible to avail tax credit. Any default towards payment of tax and / or uploading of monthly returns by supplier/contractor, NIRDESH retains right to withhold payments towards tax portion until the same is corrected & complied by the supplier/contractor with the requirement of GST along with satisfactory evidence.
9. The rate sheet enclosed with the tender will indicate the rates to be entered under each head wherever applicable. Bidders must clearly mention the applicable Taxes & Duties. The item-wise rates (i.e. Basic+P&F+F&I) quoted in the Rate Sheet should exclude Taxes & Duties. Bidder should indicate GST rates as applicable separately under each of the head in the same Rate sheet, which will be paid extra based on tax invoice to the extent applicable. The GST will be applicable on total basic rate of each item (i.e Basic + P&F + F&I).

| | | | | |
|---|---|--|-------------------|---------------------------------------|
|  | NIRDESH Kozhikode, Kerala-673301 | PROPULSION SHAFT LINE DESIGN EVALUATION AND ALIGNMENT CALCULATIONS | Tender No. & date | NIRDESH/TENDER/03 Dated 25.01.2024 |
| | | | Closing Date | 15.02.2024 (1500HRS) |
| | | | Opening Date | 16.02.2024 (1530HRS) |
| | | | PAGE | 19 of 32 |

Annexure-C: TAF (TENDER ACCEPTANCE FORM):

| TEF CLAUSE No. | BIDDER'S REMARK | TEF CLAUSE No. | BIDDER'S REMARK |
|----------------------|--------------------|-------------------|--------------------|
| | ACC. / DEV. | | ACC. / DEV. |
| 1 | | 2 | |
| 3 | | 4 | |
| 5 | | 6 | |
| 7 | | 8 | |
| 9 | | 10 | |
| 11 | | 12 | |
| 13 | | 14 | |
| 15 | | 16 | |
| 17 | | 18 | |
| 19 | | 20 | |
| 21 | | 22 | |
| 23 | | 24 | |
| 25 | | 26 | |
| 27 | | 28 | |
| 29 | | | |

COMPANY'S NAME & ADDRESS:

SIGNATURE:

DATE:

NAME:

DESIGNATION:

BIDDER'S COMPANY SEAL:

NOTE:

- Bidders should carefully read the Terms & Conditions of the Tender Enquiry Form (TEF) prior to filling up this acceptance format.
- This format should be properly filled, signed and bidder shall submit the same in **Part-I bid**.
- Bidder(s) should indicate "**ACC**" for Accepted, "**DEV**" for Deviation Taken for each clause number in the above table.
- Bidder(s) to attach Separate Sheet indicating all relevant details such as Number & description of the Clause, Reasons for Deviation and Alternative suggested for any deviations taken by them.
- Clause numbers shown in the above format also includes the sub-clauses under these clauses.

| | | | | |
|---|---|--|-------------------|---------------------------------------|
|  | NIRDESH Kozhikode, Kerala-673301 | PROPULSION SHAFT LINE DESIGN EVALUATION AND ALIGNMENT CALCULATIONS | Tender No. & date | NIRDESH/TENDER/03 Dated 25.01.2024 |
| | | | Closing Date | 15.02.2024 (1500HRS) |
| | | | Opening Date | 16.02.2024 (1530HRS) |
| | | | PAGE | 20 of 32 |

Annexure-D: GENERAL CONDITIONS OF CONTRACT (GCC)

The word '**Purchaser**' refers to NIRDESH, a Company within the meaning of Companies Act, 2013 and it includes its successors or assignees.

The word '**Bidder**' (including the term 'tenderer', 'consultant' 'vendor' or 'service provider' in certain contexts) means any legal entity such as firm(s) of Proprietorship / Partnership Firm / Limited Liability Partnership / Private Limited / Limited company / Society registered under Society's Act / Statutory Bodies/ Consortium/ Joint Venture etc. participating in a procurement process.

The word '**Owner**' means the person or authority with whom NIRDESH(Purchaser) has contracted to carry out work in relation to which orders are placed by the Purchaser on the Bidder/Supplier/Contractor under this contract for supply or manufacture of certain items and would include Department of Defence Production, Ministry of Defence, Government of India, the Indian Navy, the Coast Guard and any other specified authority. Unless otherwise indicated specifically by the bidder / contractor in his bid, it shall be construed as his acceptance of all the conditions mentioned in this GCC.

1. TENETS OF INTERPRETATION

Unless where the context requires otherwise, throughout the contract:

- (a) The heading of these conditions shall not affect the interpretation or construction thereof.
- (b) Writing or written includes matter either whole or in part, in digital communications, manuscript, typewritten, lithographed, cyclostyled, photographed, or printed under or over signature or seal or digitally acceptable authentication, as the case may be.
- (c) Words in the singular include the plural and vice-versa.
- (d) Words importing the masculine gender shall be taken to include other genders, and words importing persons shall include any company or association or body of individuals, whether incorporated or not.
- (e) Terms and expression not herein defined shall have the meanings assigned to them in the Contract Act, 1872 (as amended) or the Sale of Goods Act, 1930 (as amended) or the General Clauses Act, 1897 (as amended) or of INCOTERMS, (current edition published by the International Chamber of Commerce, Paris) as the case may be.
- (f) Any reference to 'Goods' shall be deemed to include the incidental Works/ Services also.
- (g) Any generic reference to GCC shall also imply a reference to TEF as well.
- (h) In case of conflict, provisions of TEF shall prevail over those in GCC.
- (i) Any reference to 'Contract' shall be deemed to include all other documents (inter-alia GCC, TEF).
- (j) Any reference to any legal Act, Government Policies or orders shall be deemed to include all amendments to such instruments, from time to time, till date.
- (k) Fall Clause shall be expressly applicable in the case of Rate Contract.

2. LANGUAGE OF CONTRACT

Unless otherwise stipulated in TEF, the contract shall be written in the Official Language or English. All correspondence and other contract documents, which the parties exchange, shall also be written/ translated accordingly in that language. For purposes of interpretation of the contract, the English documents/ translation shall prevail.

| | | | | |
|---|---|--|-------------------|---------------------------------------|
|  | NIRDESH Kozhikode, Kerala-673301 | PROPULSION SHAFT LINE DESIGN EVALUATION AND ALIGNMENT CALCULATIONS | Tender No. & date | NIRDESH/TENDER/03 Dated 25.01.2024 |
| | | | Closing Date | 15.02.2024 (1500HRS) |
| | | | Opening Date | 16.02.2024 (1530HRS) |
| | | | PAGE | 21 of 32 |

3. GOVERNING LAWS AND JURISDICTION

3.1 Governing Laws and Jurisdiction

(a) This Contract, its meaning and interpretation, and the relation between the Parties shall be governed by the Laws of India for the time being in force.

(b) Irrespective of the place of delivery, or the place of performance or the place of payments under the contract, the contract shall be deemed to have been made at the place from which the Purchase Order/Contract/Letter of Intent has been issued. The courts of such a place shall alone have jurisdiction to decide any dispute arising out or in respect of the contract.

3.2 Changes in Laws and Regulations

Unless otherwise stipulated in the contract, if after the last deadline for the bid submission (Techno-commercial), any law, regulation, ordinance, order or bye-law having the force of law is enacted, promulgated, abrogated, or changed in India (which shall be deemed to include any change in interpretation or application by the competent authorities) that subsequently affects the Delivery Date and/ or the contract Price, then such Delivery Date and/ or Contract Price shall be correspondingly increased or decreased, to the extent that the contractor has thereby been affected in the performance of any of its obligations under the contract. Notwithstanding the foregoing, such additional or reduced cost shall not be separately paid or credited if the same has already been accounted for in the price adjustment provisions where applicable.

4. CONFIDENTIALITY, SECRECY AND IPR RIGHTS

(a) IPR Rights

All deliverables, outputs, plans, drawings, specifications, designs, reports, and other documents and software submitted by the contractor under this Contract shall become and remain the property of NIRDESH and subject to laws of copyright and must not be shared with third parties or reproduced, whether in whole or part, without NIRDESH's prior written consent. The contractor shall, not later than upon termination or expiration of this Contract, deliver all such documents and software to NIRDESH, together with a detailed inventory thereof. The contractor may retain a copy of such documents and software but shall not use it for any commercial purpose.

(b) Confidentiality

All documents, drawings, samples, data, associated correspondence or other information furnished by or on behalf of NIRDESH to the contractor, in connection with the contract, whether such information has been furnished before, during or following completion or termination of the contract, are confidential and shall remain the property of NIRDESH and shall not, without the prior written consent of NIRDESH neither be divulged by the contractor to any third party, nor be used by him for any purpose other than the design, procurement, or other services and work required for the performance of this Contract. If advised by NIRDESH, all copies of all such information in original shall be returned on completion of the contractor's performance and obligations under this contract.

(c) Secrecy

If the Contract declares the subject matter of this Contract as coming under the Official Secrets Act, 1923 or if the contract is marked as "Secret", the contractor shall take all reasonable steps necessary to ensure that all persons employed in any connection with the contract, have acknowledged their responsibilities and penalties for violations under the Official Secrets Act and any regulations framed thereunder.

(d) Obligations of the contractor

| | | | | |
|---|---|--|-------------------|---------------------------------------|
|  | NIRDESH Kozhikode, Kerala-673301 | PROPULSION SHAFT LINE DESIGN EVALUATION AND ALIGNMENT CALCULATIONS | Tender No. & date | NIRDESH/TENDER/03 Dated 25.01.2024 |
| | | | Closing Date | 15.02.2024 (1500HRS) |
| | | | Opening Date | 16.02.2024 (1530HRS) |
| | | | PAGE | 22 of 32 |

(i) Without NIRDESH's prior written consent, the contractor shall not use the information mentioned above except for the sole purpose of performing this contract.

(ii) The contractor shall treat and mark all information as confidential (or Secret – as the case may) and shall not, without the written consent of NIRDESH, divulge to any person other than the person(s) employed by the contractor in the performance of the contract. Further, any such disclosure to any such employed person shall be made in confidence and only so far as necessary for such performance for this contract.

(iii) Notwithstanding the above, the contractor may furnish to its holding company or its Subcontractor(s) such documents, data, and other information it receives from NIRDESH to the extent required for performing the contract. In this event, the contractor shall obtain from such holding company/ Subcontractor(s) an undertaking of confidentiality (or secrecy – as the case may be) similar to that imposed on the contractor under the above clauses.

(iv) The obligation of the contractor under sub-clauses above, however, shall not apply to information that:

(aa) The contractor needs to share with the institution(s) participating in the financing of the contract;

(ab) now or hereafter is or enters the public domain through no fault of Contractor;

(ac) can be proven to have been possessed by the contractor at the time of disclosure and which was not previously obtained, directly or indirectly, from NIRDESH; or

(ad) otherwise lawfully becomes available to the contractor from a third party that has no obligation of confidentiality.

(v) The above provisions shall not in any way modify any undertaking of confidentiality (or Secrecy – as the case may be) given by the contractor before the date of the contract in respect of the contract/ the Tender Document or any part thereof.

(vi) The provisions of this clause shall survive completion or termination for whatever reason of the contract.

5. PERMITS, APPROVALS AND LICENSES

Whenever the supply of Goods and incidental Services requires that the contractor obtain permits, approvals, and licenses from local public authorities, it shall be the contractor's sole responsibility to obtain these and keep these current and valid. Such requirements may include but not be restricted to export licence or environmental clearance if required. If requested by the contractor, NIRDESH shall make its best effort to assist the contractor in complying with such requirements in a timely and expeditious manner, without any dilution of the Contractor's responsibility in this regard.

6. EXTENSION OF DELIVERY PERIOD

(a) If at any time during the currency of the contract, the contractor encounters conditions hindering timely delivery of the Goods and performance of incidental Works/ Services, he shall promptly inform NIRDESH in writing about the same and its likely duration. He must make a request to NIRDESH for an extension of the

| | | | | |
|---|---|--|-------------------|---------------------------------------|
|  | NIRDESH Kozhikode, Kerala-673301 | PROPULSION SHAFT LINE DESIGN EVALUATION AND ALIGNMENT CALCULATIONS | Tender No. & date | NIRDESH/TENDER/03 Dated 25.01.2024 |
| | | | Closing Date | 15.02.2024 (1500HRS) |
| | | | Opening Date | 16.02.2024 (1530HRS) |
| | | | PAGE | 23 of 32 |

delivery schedule. On receiving the contractor's communication, NIRDESH shall examine the situation and, at its discretion, may agree to extend the delivery schedule, with or without liquidated damages and with and without denial clause by issuing an amendment to the contract.

(b) Conditions for Extension of Delivery Period

When the period of delivery is extended due to unexcused delay (Note: please ensure that unexcused delay is defined. Otherwise replace "unexcused delay" with the "delays attributable") by the contractor, the amendment extending the delivery period shall, inter alia, be subject to the following conditions:

(i) Denial Clause

(aa) No increases in price on account of any statutory increase in or fresh imposition of GST, customs duty or on account of any other taxes/ duty/ cess/ levy), leviable in respect of the Goods and incidental Works/ Services stipulated in the said contract which takes place after the original delivery date, shall be admissible on such of the said Goods, as are delivered after the said date; and

(ab) Notwithstanding any stipulation in the contract for an increase in price on any other ground, including price variation clause or foreign exchange rate variation, or any other variation clause, no such increase after the original delivery date shall be admissible on such goods delivered after the said date.

(ac) Nevertheless, NIRDESH shall be entitled to the benefit of any decrease in price on account of reduction in or remission of GST, customs duty or on account of any other Tax or duty or any other ground as stipulated in the price variation clause or foreign exchange rate variation or any other variation clause which takes place after the expiry of the original delivery date.

7. DEFAULTS, BREACHES & TERMINATION OF CONTRACT

Termination due to Breach, Default, and Insolvency

(a) Defaults and Breach of Contract

In case the contractor undergoes insolvency or receivership; neglects or defaults, or expresses inability or disinclination to honour his obligations relating to the performance of the contract or ethical standards or any other obligation that substantively affects NIRDESH's rights and benefits under the contract, it shall be treated as a breach of Contract. Such defaults shall include inter-alia:

(i) Default in Performance and Obligations

If the contractor fails to deliver any or all of the Goods or fails to perform any other contractual obligations (including Code of Integrity or obligation to maintain eligibility and Qualifications based on which contract was awarded) within the period stipulated in the contract or within any extension thereof granted by NIRDESH.

(ii) Insolvency

If the contractor is wound up or ceases to otherwise trade or is unable to pay its debts as and when they fall due or is otherwise subject to any insolvency procedure.

(iii) If a receiver or similar official is appointed overall or any of the assets of the contractor or a petition is presented for its winding up or it entered into a composition with its creditors;

(b) Notice for Default

| | | | | |
|---|---|--|-------------------|---------------------------------------|
|  | NIRDESH Kozhikode, Kerala-673301 | PROPULSION SHAFT LINE DESIGN EVALUATION AND ALIGNMENT CALCULATIONS | Tender No. & date | NIRDESH/TENDER/03 Dated 25.01.2024 |
| | | | Closing Date | 15.02.2024 (1500HRS) |
| | | | Opening Date | 16.02.2024 (1530HRS) |
| | | | PAGE | 24 of 32 |

As soon as a breach of contract is noticed, a show-cause 'Notice of Default' shall be issued to the contractor, giving two weeks' notice, reserving the right to invoke contractual remedies. After such a show-cause notice, all payments to the contractor would be temporarily withheld to safeguard needed recoveries that may become due on invoking contractual remedies.

(c) Terminations for Default

(i) Notice for Termination for Default: In the event of unsatisfactory resolution of 'Notice of Default' within two weeks of its issue as per subclause above, NIRDESH if so decided, shall by written Notice of Termination for Default sent to the contractor, terminate the contract in whole or in part, without compensation to the contractor.

(ii) Such termination shall not prejudice or affect the rights and remedies, including under sub-clause below, which have accrued and/ or shall accrue to NIRDESH after that.

(iii) Unless otherwise instructed by NIRDESH, the contractor shall continue to perform the contract to the extent not terminated. All warranty obligations, if any, shall continue to survive despite the termination.

(d) Contractual Remedies for Breaches/Defaults or Termination for Default

If there is an unsatisfactory resolution within this period, NIRDESH shall take one; or more of the following contractual remedies.

(i) Temporary withhold payments due to the contractor till recoveries due to invocation of other contractual remedies are complete.

(ii) Call back any loaned property or advances of payment, if any, with the levy of interest at the prevailing rate (MIBID - Mumbai Interbank Bid Rate).

(iii) Recover liquidated damages and invoke denial clause for delays.

(iv) Encash and/ or Forfeit performance or other contractual securities.

(v) Prefer claims against insurances, if any.

(vi) Terminate contract for default, fully or partially including its right for Risk and Cost Procurement as per following sub-clause.

(vii) Risk and Cost Procurement

In addition to termination for default, NIRDESH shall be entitled, and it shall be lawful on his part, to procure Goods same to those terminated, with such terms and conditions and in such manner as it deems fit at the "Risk and Cost" of the contractor. Such 'Risk and Cost Procurement' must be initiated (viz. AIP/PR/Tender) within six months from the termination of Contract. The Contractor shall be liable for any loss which NIRDESH may sustain on that account provided the procurement, or, if there is an agreement to procure, such agreement is made. The Contractor shall not be entitled to any gain on such procurement, and the manner and method of such procurement shall be in the entire discretion of NIRDESH.

(Note: deleted being contrary to law).

(Note: No contractor would give security after the termination of the contract)

Note: Regarding the Goods which are not readily available in the market and where procurement difficulties are experienced, the period for making risk procurement shall be nine months instead of six months provided above.

(viii) Initiate legal proceedings in a for the recovery of the losses and damages, not addressable by the above means.

8. CLOSURE OF CONTRACT

| | | | | |
|---|---|--|-------------------|---------------------------------------|
|  | NIRDESH Kozhikode, Kerala-673301 | PROPULSION SHAFT LINE DESIGN EVALUATION AND ALIGNMENT CALCULATIONS | Tender No. & date | NIRDESH/TENDER/03 Dated 25.01.2024 |
| | | | Closing Date | 15.02.2024 (1500HRS) |
| | | | Opening Date | 16.02.2024 (1530HRS) |
| | | | PAGE | 25 of 32 |

The contract shall stand closed upon successful performance of all obligations by the firm, including completion of warrantee obligations and final payment. If no claim is received within 03 years from last supplies/services, then no claim shall be entertained thereafter.

9. COMMUNICATION AND LANGUAGE FOR DOCUMENTATION

Any letter, facsimile message, e-mail intimation or notice sent to the Bidder/Supplier/ Contractor at the last known address mentioned in the offer / order shall be deemed to be valid communication for the purpose of the order/contract. Unless stated otherwise by the purchaser, Language for communication and all documentation shall be same, which the Purchaser has used, in the tender enquiry.

10. CANCELLATION OF TENDER

The Purchaser reserves the right to cancel/withdraw the tender in toto or part and or award the contract / order in full or part without assigning any reason whatsoever and without thereby incurring any liability to the affected Bidder or Bidders or any obligations to inform the affected Bidder or Bidders of the grounds for NIRDESH action.

11. PURCHASER'S PROPERTY.

All property (such as materials, drawings, documents etc.) issued by the Purchaser or any other individual or firm on behalf of the Purchaser in connection with the contract shall remain confidential, being the property of the Purchaser and the Bidder/Supplier/Contractor shall undertake to return all such property so issued and will be responsible for any or all loss thereof and damage thereto resulting from whatever causes and shall reimburse the Purchaser the full amount of loss and damage. On completion of work in any compartment / location of the purchaser's premises, the Bidder/Supplier/Contractor must ensure that the place is left in a reasonably clean state and all scrap is transferred to nearby scrap-bins.

12. RECOVERY-ADJUSTMENT PROVISIONS

Payment made under one order shall not be assigned or adjusted to any other order except to the extent agreed upon in writing by the Purchaser. During the currency of the contract, if any sum of money is payable by the Bidder / Supplier / Contractor the same shall be deducted from any sum then due or thereafter may become due to the Bidder / Supplier / Contractor under the contract or any other contract with the Purchaser.

13. INDEMNIFICATION

The Bidder / Supplier / Contractor, his employees, licences, agents or Sub-Supplier / Sub-contractor, while on site of the Purchaser for the purpose of this contract, indemnifies the Purchaser against direct damage and/or injury to the property and/or the person of the Purchaser or that of Purchaser's employees, agents, Sub- Contractors / Suppliers occurring and to the extent caused by the negligence of the Bidder / Supplier / Contractor, his employees, licensees, agents or Sub-contractor by making good such damages to the property, or compensating personal injury and the total liability for such damages or injury shall be as mutually discussed and agreed to.

14. TRANSFER OF SUPPLIERS / CONTRACTOR'S RIGHTS

| | | | | |
|---|---|--|-------------------|---------------------------------------|
|  | NIRDESH Kozhikode, Kerala-673301 | PROPULSION SHAFT LINE DESIGN EVALUATION AND ALIGNMENT CALCULATIONS | Tender No. & date | NIRDESH/TENDER/03 Dated 25.01.2024 |
| | | | Closing Date | 15.02.2024 (1500HRS) |
| | | | Opening Date | 16.02.2024 (1530HRS) |
| | | | PAGE | 26 of 32 |

The Bidder / Supplier / Contractor shall not either wholly or partly sell, transfer, assign or otherwise dispose of the rights, liabilities and obligations under the contract between him and the Purchaser without prior consent of the Purchaser in writing.

15. SUBCONTRACT AND RIGHT OF PURCHASER

The Bidder / Supplier / Contractor under no circumstances undertake or subcontract any work / contract from or to any other Sub-contractor without prior written approval of the Competent Authority of Purchaser. In the event it is found that such practice has been indulged in, the contract is liable to be terminated without notice and the Bidder / Supplier / Contractor is debarred all from future tender enquiries / work orders. However, in no circumstances a contractor is permitted to subcontract any part of the contract to the bidders who had quoted for the concerned tender.

16. PATENT RIGHTS

The Bidder / Supplier / Contractor shall hold harmless and keep the Purchaser indemnified against all claims arising as a result of infringement of any patent / copy rights on account of manufacture, sale or use of articles covered by the order.

17. USE OF UNDUE INFLUENCE / CORRUPT PRACTICES

The Bidder / Supplier / Contractor undertakes that he has not used corrupt practices or used any undue influence which is not admissible as per Indian law to obtain contract/order or in doing any business with the purchaser. If found that Bidder / Supplier / Contractor is involved in such wrong practices, then Purchaser is entitled to cancel the contract/s and all or any other contracts and then to recover from the Bidder / Supplier / Contractor the amounts of any loss arising from such contracts' cancellation, including but not limited to imposition of penal damages, forfeiture of Performance security, encashment of the Bank Guarantee and refund of the amounts paid by the Purchaser.

18. IMMUNITY OF GOVERNMENT OF INDIA CLAUSE

It is expressly understood and agreed by and between M/s. (Bidder / Supplier / Contractor) and NIRDESH is entering into this Agreement solely on its own behalf and not on the behalf of any person or entity. In particular, it is expressly understood and agreed that the Government of India is not a party to this Agreement and has no liabilities, obligations or rights hereunder. It is expressly understood and agreed that NIRDESH is an independent legal entity with power and authority to enter into contracts solely in its own behalf under the applicable of Laws of India and general principles of Contract Law. The (Bidder / Supplier / Contractor) expressly agrees, acknowledges and understands that NIRDESH is not an agent, representative or delegate of the Government of India. It is further understood and agreed that the Government of India is not and shall not be liable for any acts, omissions and commissions, breaches or other wrongs arising out of the contract. Accordingly, (Bidder / Supplier / Contractor) hereby expressly waives, releases and foregoes any and all actions or claims, including cross claims, impleader claims or counter claims against the Government of India arising out of this contract and covenants not to sue Government of India in any manner, claim, cause of action or thing whatsoever arising of or under this Agreement.

19. BANNED OR DE-LISTED CONTRACTORS / SUPPLIERS

The Bidder / Supplier / Contractor declares that they being Proprietors / Directors / Partners have not been any time individually or collectively blacklisted or banned or de-

| | | | | |
|---|---|--|-------------------|---------------------------------------|
|  | NIRDESH Kozhikode, Kerala-673301 | PROPULSION SHAFT LINE DESIGN EVALUATION AND ALIGNMENT CALCULATIONS | Tender No. & date | NIRDESH/TENDER/03 Dated 25.01.2024 |
| | | | Closing Date | 15.02.2024 (1500HRS) |
| | | | Opening Date | 16.02.2024 (1530HRS) |
| | | | PAGE | 27 of 32 |

listed by any Government or quasi Government agencies or PSUs. If a bidder's entities as stated above have been blacklisted or banned or de-listed by any Government or quasi Government agencies or PSUs, this fact must be clearly stated and it may not necessarily be a cause for disqualifying him.

20. DUTY OF PERSONNEL OF SUPPLIER/CONTRACTOR

Bidder / Supplier / Contractor undertakes that their personnel deployed in connection with the entrusted work will not indulge in any activities other than the duties assigned to them.

21. DISPUTE RESOLUTION MECHANISM AND ARBITRATION

(a) Dispute resolution mechanism(DRM)

(i) Any dispute/differences between the parties arising out of and in connection with the contract shall be settled amicably by mutual negotiations at HoS/HoD level.

(ii) In case of non-settlement by (i) above, if at any time, before, during or after the contract period any unsettled claim, dispute or difference arose between the parties, upon or in relation to or in connection with or in any way touching or concerning this tender/agreement/order/contract, the same shall be referred to the concerned Functional Director. The Functional Director shall then nominate an Executive of the rank of General Manager whom he thinks fit and competent or a Committee of Executives who/which shall then scrutinise the claims/disputes that have been referred to the concerned functional Director and make efforts for amicable settlements by mutual discussions/negotiations.

(iii) In case no amicable settlement is arrived by (ii) above within a period of three months, then the contractor shall approach Public Grievance Cell and address the disputes as per the provisions made under the relevant clause of the contract.

(iv) In case the issues/disputes do not get settled within a period of six months from the date of submission of the dispute to the Grievance Cell, then the contractor may invoke Arbitration Clause of the contract.

(b) Arbitration

(i) Unresolved disputes/differences, if any, shall then be settled by Arbitration. The Arbitration proceedings shall be conducted at Mumbai, India, in English Language, under the Arbitration and Conciliation Act, 1996 as amended from time to time and the rules thereunder.

(ii) NIRDESH prefers to have arbitration through Institutes such as Indian Council of Arbitration (ICA)/ICA-DR, Mumbai Centre for International Arbitration, International Chamber of Commerce (ICC), Singapore International Arbitration Centre (SIAC) with the mutual consent of the parties.

(iii) In case of unresolved difference/dispute between the Purchaser and Supplier, being Central Public Sector Enterprises/Central Govt. departments, the disputes shall be resolved firstly through mutual discussion or through the empowered agencies of the Govt. or through arbitration by reference by either party to the department of Public Enterprises, as per extant guidelines. If disputes/differences remain unresolved/unexecuted, the same shall be referred first to the Cabinet Secretariat and then, if necessary to the PMO.

22. JURISDICTION OF COURTS

All contracts shall be deemed to have been wholly made in Mumbai and all claims there under are payable in Mumbai City and it is the distinct condition of the order that no suit

| | | | | |
|---|---|--|-------------------|---------------------------------------|
|  | NIRDESH Kozhikode, Kerala-673301 | PROPULSION SHAFT LINE DESIGN EVALUATION AND ALIGNMENT CALCULATIONS | Tender No. & date | NIRDESH/TENDER/03 Dated 25.01.2024 |
| | | | Closing Date | 15.02.2024 (1500HRS) |
| | | | Opening Date | 16.02.2024 (1530HRS) |
| | | | PAGE | 28 of 32 |

or action for the purpose of enforcing any claim in respect of the order shall be instituted in any Court other than that situated in Mumbai City, Maharashtra State, India i.e. courts in Mumbai shall alone have jurisdiction to decide upon any dispute arising out of or in respect of the contract.

23. MINIMUM WAGES ACT

The Contractor / Bidder shall pay to his employees not less than the minimum wages and allowances applicable to the Engineering Industry as notified from time to time by the Central Government or the State Government whichever is higher under the Minimum Wages Act. Contractor / Bidder shall be responsible for timely payment of wages of all his employees engaged in the Purchaser's Yard, not less than the prescribed minimum wages in each case and without any deductions of any kind, except as specified by Government or permissible under the Payment of Wages Act.

The Contractor / Bidder must settle all the pending dues of the employees i.e. arrears of wages, proportionate leave wages, proportionate bonus payment, etc. Before winding up the site, the Contractor / Bidder shall pay all terminal dues to his employees such as Notice pay, Gratuity, Retrenchment compensation, etc.

24. BONUS ACT

The Contractor / Bidder shall pay to his eligible employees a Statutory Bonus as per 'Payment of Bonus Act' at the rate prescribed by the Statutory Authorities from time to time.

25. SAFETY

The Contractor / Bidder must observe all safety precautions in connection with the work to be performed by him, his agents or labourers. In the event of any accident happening in our yard resulting in loss of lives or otherwise damaging any part of the property, the contractor shall be required to make good the loss to the Company and shall be responsible for all consequences that follow from the loss and / or injuries to the persons involved in such accidents. The standard of safety to be observed in the Company shall be decided by the Executive-in-Charge Safety, or any Executive appointed for the purpose before the commencement of work in the yard. It will be essential for contractor to ascertain the standard precautions which contractor is required to observe in discharging his work as per the standards prevalent in NIRDESH. The decision of NIRDESH in matters concerning Safety shall be final and binding on the contractor.

The Contractor / Bidder shall be required to provide his workmen with Boiler Suits of any suitable colour other than blue or white, with the Name of the Contractor in prominent letters on the boiler suits along with personal protection gears like safety shoes, hand gloves etc. workmen of the Contractor / Bidder must wear throughout their working while in the premises of NIRDESH. Contractor's workmen working without safety gears are to be disallowed for work.

26. POLICE VERIFICATION OF EMPLOYEES

Contractor / Bidder shall have to produce and submit to the Chief Security Executive of Purchaser, verification through Mumbai Police of Character and Antecedents of their employees / workers Entry passes will not be issued in the absence of Police Verification Report and employees without Police Verification shall not be employed by them in Purchaser's Yard and any lapse on the part of Contractor / Bidder shall be viewed

| | | | | |
|---|---|--|-------------------|---------------------------------------|
|  | NIRDESH Kozhikode, Kerala-673301 | PROPULSION SHAFT LINE DESIGN EVALUATION AND ALIGNMENT CALCULATIONS | Tender No. & date | NIRDESH/TENDER/03 Dated 25.01.2024 |
| | | | Closing Date | 15.02.2024 (1500HRS) |
| | | | Opening Date | 16.02.2024 (1530HRS) |
| | | | PAGE | 29 of 32 |

seriously as per applicable laws of the land. Employment of any Foreign National during the contract period would be permitted with prior permission of Purchaser.

| | | | | |
|---|---|--|-------------------|---------------------------------------|
|  | NIRDESH Kozhikode, Kerala-673301 | PROPULSION SHAFT LINE DESIGN EVALUATION AND ALIGNMENT CALCULATIONS | Tender No. & date | NIRDESH/TENDER/03 Dated 25.01.2024 |
| | | | Closing Date | 15.02.2024 (1500HRS) |
| | | | Opening Date | 16.02.2024 (1530HRS) |
| | | | PAGE | 30 of 32 |

Annexure-E: GENERAL CONDITIONS OF CONTRACT ACCEPTANCE FORMAT:

| GCC CLAUSE No. | BIDDER'S REMARK | GCC CLAUSE No. | BIDDER'S REMARK |
|----------------|-----------------|----------------|-----------------|
| | ACC. / DEV. | | ACC. / DEV. |
| 1 | | 2 | |
| 3 | | 4 | |
| 5 | | 6 | |
| 7 | | 8 | |
| 9 | | 10 | |
| 11 | | 12 | |
| 13 | | 14 | |
| 15 | | 16 | |
| 17 | | 18 | |
| 19 | | 20 | |
| 21 | | 22 | |
| 23 | | 24 | |
| 25 | | 26 | |

COMPANY'S NAME & ADDRESS:

SIGNATURE:

DATE:

NAME:

DESIGNATION:

BIDDER'S COMPANY SEAL:

NOTE:

- Bidders should carefully read the General Conditions of Contract of the Tender (GCCs) prior to filling up this acceptance format
- This format should be properly filled, signed and bidder shall submit the same with Part-I bid.
- Bidder(s) should indicate "ACC" for Accepted, "DEV" for Deviation Taken for each clause number in the above table.
- Bidder(s) to attach Separate Sheet indicating all relevant details such as Number & description of the Clause, Reasons for Deviation and Alternative suggested for any deviations taken by them.

| | | | | |
|---|---|--|-------------------|---------------------------------------|
|  | NIRDESH Kozhikode, Kerala-673301 | PROPULSION SHAFT LINE DESIGN EVALUATION AND ALIGNMENT CALCULATIONS | Tender No. & date | NIRDESH/TENDER/03 Dated 25.01.2024 |
| | | | Closing Date | 15.02.2024 (1500HRS) |
| | | | Opening Date | 16.02.2024 (1530HRS) |
| | | | PAGE | 31 of 32 |

**Annexure-F: DECLARATION BY BIDDER REGARDING CONFLICT OF INTEREST
AMONG BIDDERS/ AGENTS**

- i. I have read the tender clause no. 28 regarding Conflict of Interest among Bidders/ Agents; I certify that our Firm M/s.....is not having any conflict of interest with any bidder/agent participating in this bidding process.
- ii. I hereby certify that our Firm M/s.....fulfils all requirements in this regard and is eligible to be considered for subject tender.

COMPANY'S NAME & ADDRESS:

SIGNATURE:

DATE:
NAME:
DESIGNATION:
BIDDER'S COMPANY SEAL:



**MAZAGON DOCK
SHIPBUILDERS LTD.**
(A Govt. Of India Undertaking)
Dockyard Road, Mumbai -400 010.

SHIP BUILDING DESIGN
**PROPULSION SHAFT LINE
DESIGN EVALUATION AND
ALIGNMENT CALCULATIONS**

| | |
|----------|-----------------------------|
| DOC NO. | R&D/2023/SHAFT ALIGNMENT |
| REV. NO. | 01 |
| DATE | 16 Aug 23 |
| PAGE | 32 of 32 |

Annexure-G

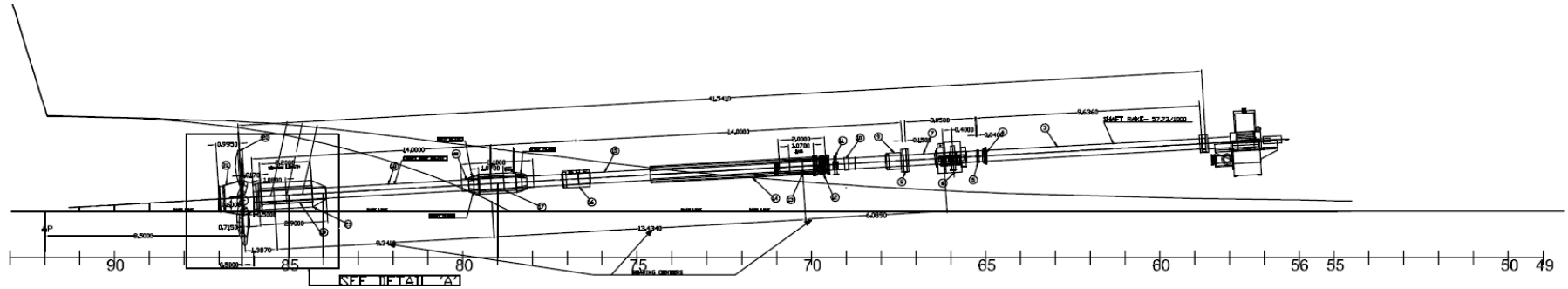

PROFILE VIEW

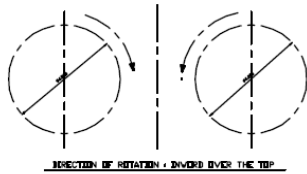

VERTICAL HATCH FOR LOADING PROVISION

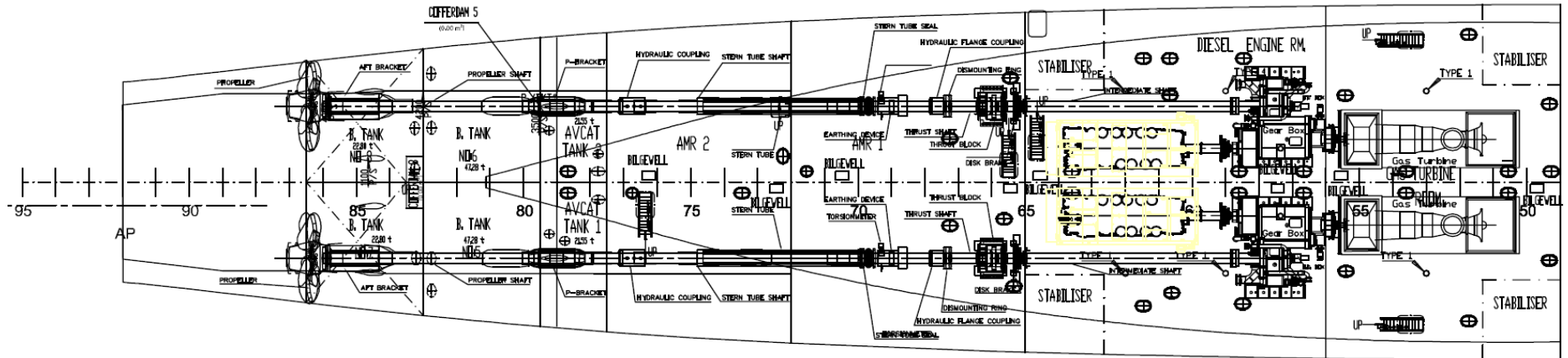

PLAN VIEW